

CAT. NO.	WIRE RANGE	STUD SIZE [METRIC SIZE]	MECHANICAL TOOLING	4 HYDRAULIC TOOLING				DIELESS TOOLING	NO. CRIMPS	WIRE STRIP LENGTH	REV	DATE	DESCRIPTION	ECO	BY	C'H'K.
				DIE INDEX	TOOL CAT. NO.	4 DIE TYPE	DIE CAT. NO.				A	10/24/2012	CREATE SALES DRAWING	29190	RG	MA
YAD8CM8E516	8 AWG STR. CU CODE & FLEX [6-10]mm ²	5/16" [8]	Y1MRTC, Y8MRB-1, RED GROOVE	1013	Y35, Y39, Y750, PAT750	NEST INDENTOR	UV8L Y34PL	Y81KFT- SERIES PAT81KFT- SERIES Y4PC834- SERIES PAT4PC834- SERIES	1	3/8"						

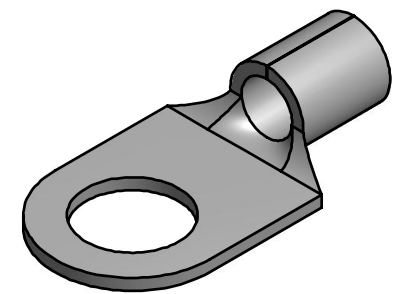
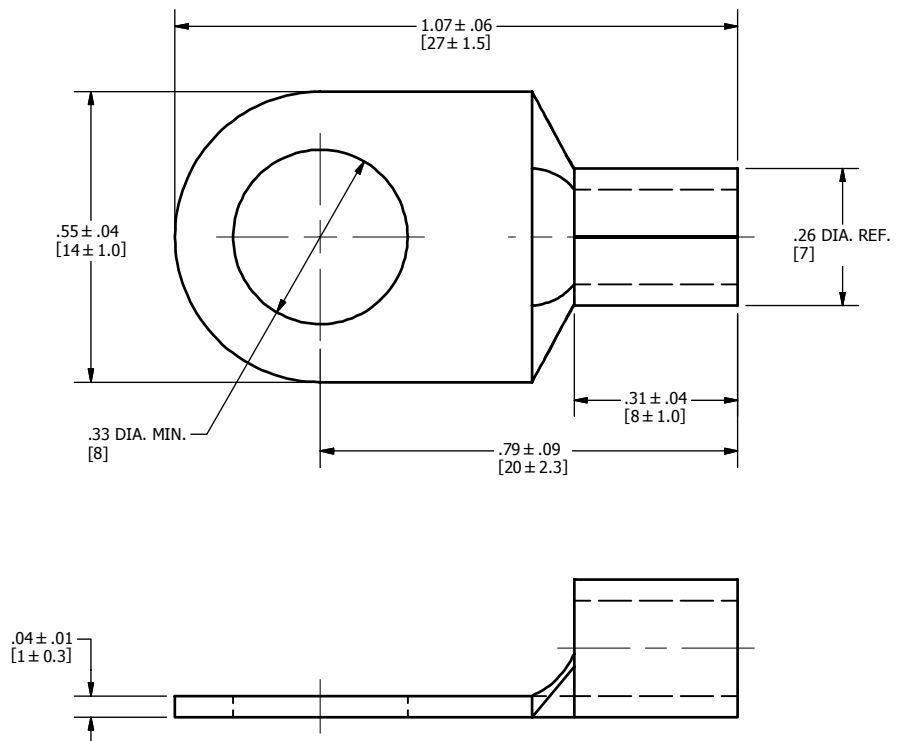

NOTES:

1. MATERIAL: COPPER.
2. FINISH: TIN PLATED.
- 3 PERMANENT DIE IN TOOLING.
- 4 Y35P3 ADAPTOR REQUIRED FOR Y34PL INDENTORS IN Y35, Y39, Y750 AND PAT750 TOOLS.
5. DIMENSIONS IN BRACKETS [] ARE IN MILLIMETERS ROUNDED OFF TO THE NEAREST MILLIMETER, UNLESS OTHERWISE NOTED, AND ARE FOR REFERENCE ONLY.

TO ORDER BURNDY PRODUCTS CALL		NON-INSULATED BRAZED BARREL COPPER TERMINAL	
UNITED STATES		ITEM NO: 50002379	
1-800-346-4175 (LONDONDERRY, NH)		CAT. NO: YAD8CM8E516	
CANADA:		DRAWN BY: C.KAJEV 10/25/2012	
1-800-361-6975 (QUEBEC)		CHECKER: J.MICHAUD 11/29/2012	
1-800-387-6487 (ALL OTHER PROVINCES)		DSN APRV: J.MICHAUD 11/29/2012	
FOR PRODUCT INFO: http://www.burndy.com		MFG APRV: --	
		QA APRV: S.GALE 11/29/2012	
		MKT APRV: C.KOWALCZYK 11/29/2012	
		PROD PART: CMR/COMPRESSION	
		DRAWING NO	
		50010575	
		REV	
		A	
		SHEET 1 OF 1	