

CAT. NO.	3 MECHANICAL TOOLING	4 HYDRAULIC TOOLING			DIELESS TOOLING	NO. CRIMPS	WIRE STRIP LENGTH
		DIE INDEX	TOOL CAT. NO.	4 DIE TYPE			
YAD6CM12E12	Y1MRTC BLUE GROOVE	----	Y35, Y39, Y750, PAT750	NEST INDENTOR	UV6L Y34PL	Y81KFT- SERIES PAT81KFT- SERIES Y4PC834- SERIES PAT4PC834- SERIES	1 7/16"

REV	DATE	DESCRIPTION	ECO	BY	C'H'K.
A	10/25/2012	SALES DRAWING RELEASE	29191	DK	MA

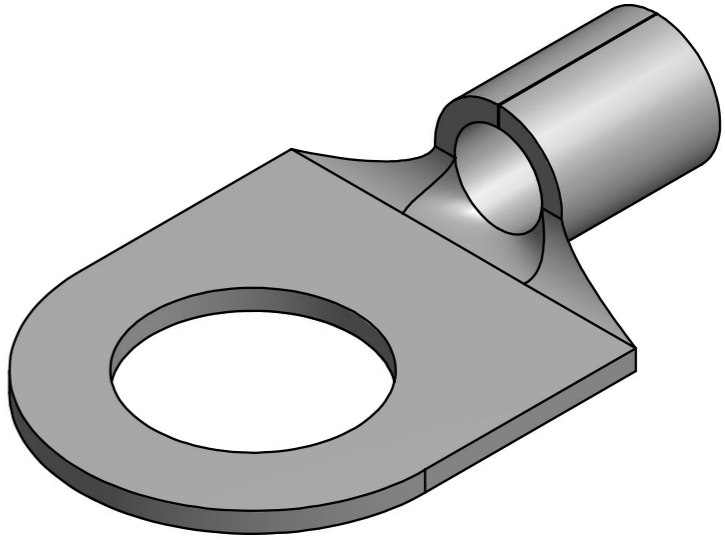
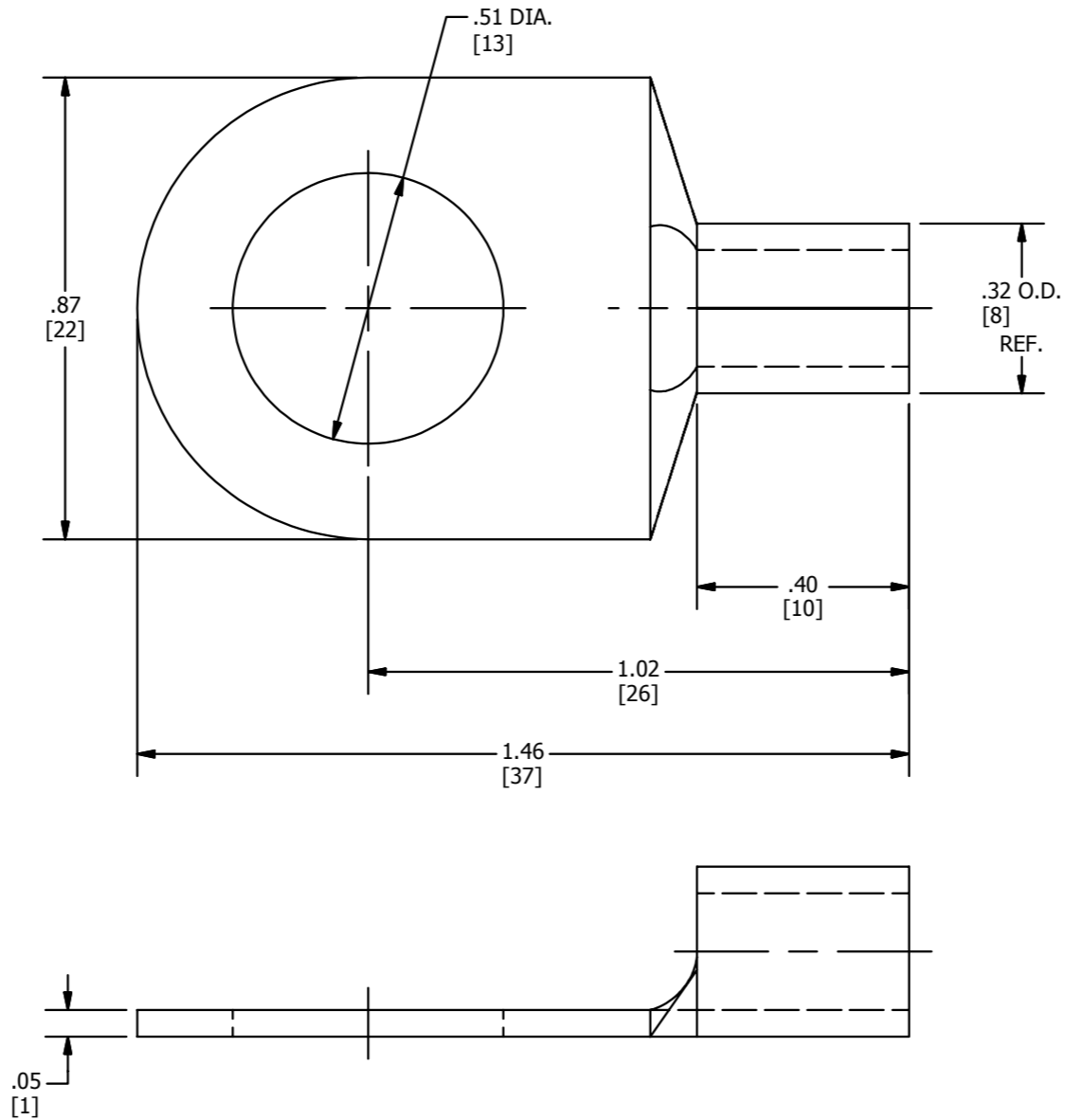

NOTES:

1. MATERIAL: COPPER.
2. FINISH: TIN PLATED.
- 3 PERMANENT DIE IN TOOLING.
- 4 Y35P3 ADAPTOR REQUIRED FOR Y34PL INDENTORS IN Y35, Y39, Y750 AND PAT750 TOOLS.
5. DIMENSIONS IN BRACKETS [ ] ARE IN MILLIMETERS ROUNDED OFF TO THE NEAREST MILLIMETER, UNLESS OTHERWISE NOTED, AND ARE FOR REFERENCE ONLY.

TO ORDER BURNDY PRODUCTS CALL		NON-INSULATED BRAZED BARREL COPPER TERMINAL	
UNITED STATES		ITEM NO: 50002387	
1-800-346-4175 (LONDONDERRY, NH)		CAT. NO: YAD6CM12E12	
CANADA:		DRAWN BY: N.D.KANNAN 10/25/2012	
1-800-361-6975 (QUEBEC)		CHECKER: J.MICHAUD 11/29/2012	
1-800-387-6487 (ALL OTHER PROVINCES)		DSN APRVL: J.MICHAUD 11/29/2012	
FOR PRODUCT INFO: <a href="http://www.burndy.com">http://www.burndy.com</a>		MFG APRVL: C.KOWALCZYK 11/29/2012	
		MKT APRVL: S.GALE 11/28/2012	
		PROJ #:	
		DRAWING NO	
		50010633	
		REV	
		A	
		SHEET 1 OF 1	