

CAT. NO.	WIRE RANGE	STUD SIZE [METRIC SIZE]	HYDRAULIC TOOLING			DIELESS TOOLING	NO. CRIMPS	WIRE STRIP LENGTH	REV	DATE	DESCRIPTION	ECO	BY	C'H'K.
			DIE INDEX	TOOL CAT. NO.	DIE TYPE				DIE CAT. NO.	A	10/29/2012	CREATE SALES DRAWING	29205	RG
YAD4CM8E516	4 AWG STR. CU CODE & FLEX [16-25]mm <sup>2</sup>	5/16" [8]	1017	Y35, Y39, Y750, PAT750	NEST INDENTOR	U2CD1 Y34PR	Y81KFT- SERIES PAT81KFT- SERIES Y4PC834- SERIES PAT4PC834- SERIES	1						

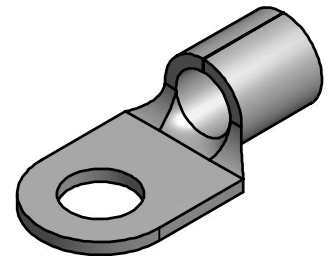
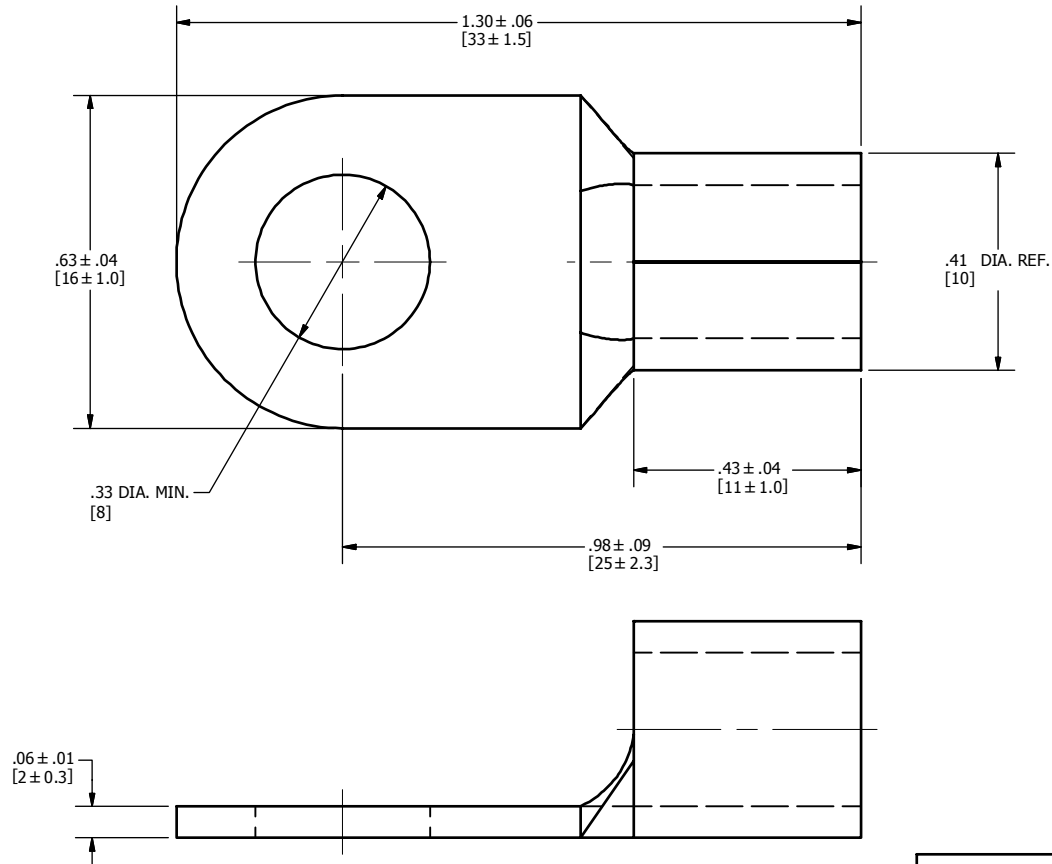

NOTES:

1. MATERIAL: COPPER.
2. FINISH: TIN PLATED.
3. Y35P3 ADAPTOR REQUIRED FOR Y34PL INDENTORS IN Y35, Y39, Y750 AND PAT750 TOOLS.
4. DIMENSIONS IN BRACKETS [ ] ARE IN MILLIMETERS ROUNDED OFF TO THE NEAREST MILLIMETER, UNLESS OTHERWISE NOTED, AND ARE FOR REFERENCE ONLY.

TO ORDER BURNDY PRODUCTS CALL		NON-INSULATED BRAZED BARREL COPPER TERMINAL	
UNITED STATES		ITEM NO: 50002390	
1-800-346-4175 (LONDONDERRY, NH)		CAT. NO: YAD4CM8E516	
CANADA:		DRAWN BY: C.KAHEY 10/29/2012	
1-800-361-6975 (QUEBEC)		CHECKER: J.MICHAUD 11/29/2012	
1-800-387-6487 (ALL OTHER PROVINCES)		DSN APRVL: J.MICHAUD 11/29/2012	
FOR PRODUCT INFO: <a href="http://www.burndy.com">http://www.burndy.com</a>		MFG APRVL: -- --	
		QA APRVL: S.GALE 11/29/2012	
		MKT APRVL: C.KOWALCZYK 11/29/2012	
		PROJ PART: CMR/COMPRESSION	
		PROJECT #:	
		SIZE	
		DRAWING NO	
		REV	
		50013647	
		A	
		SHEET 1 OF 1	