

CAT. NO.	WIRE RANGE	STUD SIZE [METRIC SIZE]	HYDRAULIC TOOLING				DIELESS TOOLING	NO. CRIMPS	WIRE STRIP LENGTH
			DIE INDEX	TOOL CAT. NO.	DIE TYPE	DIE CAT. NO.			
YAD28M6E14	4/0 AWG STR. CU CODE & FLEX [95-120]mm ²	1/4" [6]	1026	Y35, Y39, Y750, PAT750	NEST	U32D1	Y81KFT- SERIES PAT81KFT- SERIES Y4PC834- SERIES PAT4PC834- SERIES	1	1"
					INDENTOR	Y34PR2			

REV	DATE	DESCRIPTION	ECO	BY	C'H'K.
A	10/29/2012	CREATE SALES DRAWING	29247	BT	MA

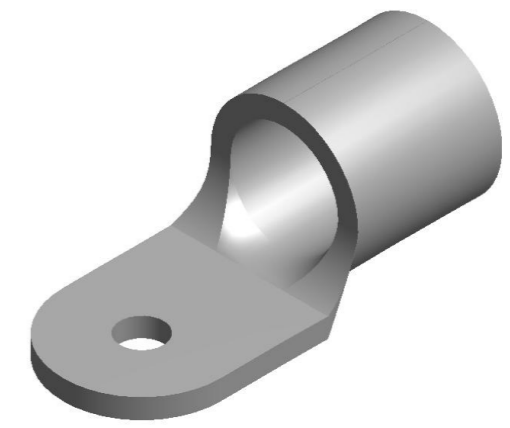
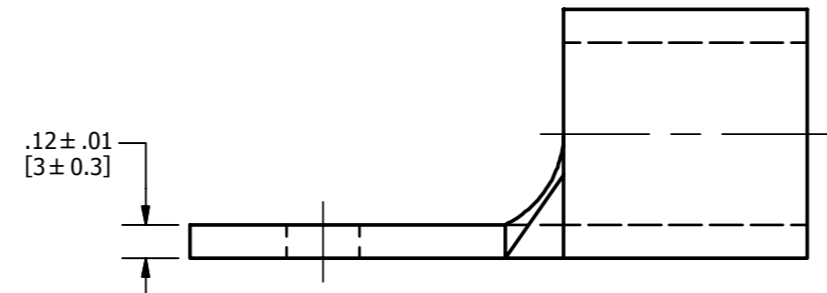
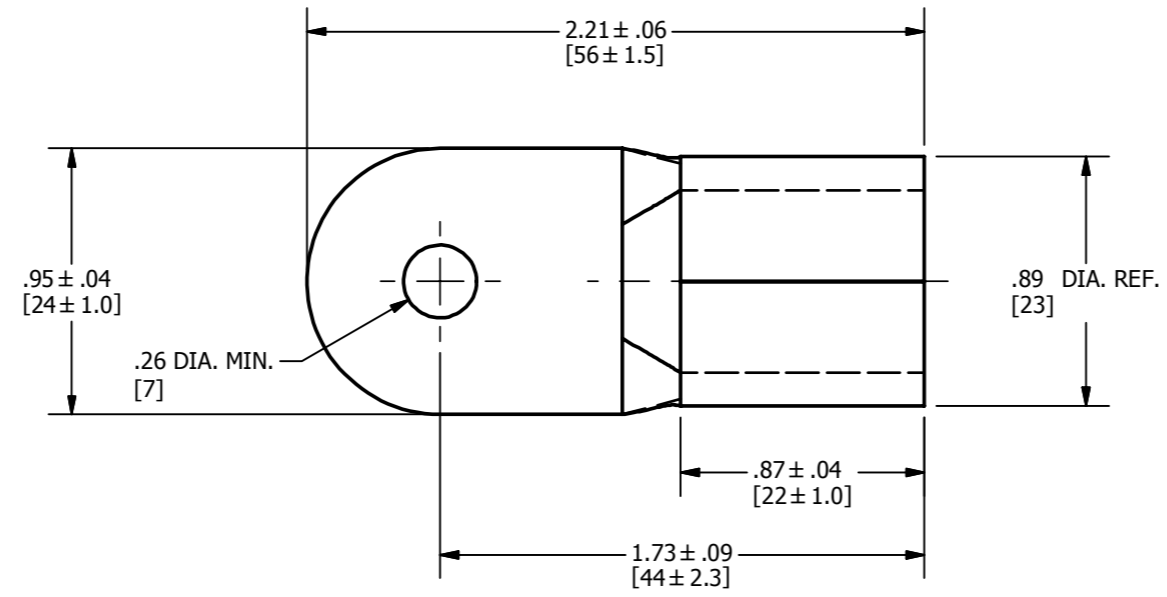

NOTES:

1. MATERIAL: COPPER.
2. FINISH: TIN PLATED.
3. Y35P3 ADAPTOR REQUIRED FOR Y34PR2 INDENTORS IN Y35, Y39, Y750 AND PAT750 TOOLS.
4. DIMENSIONS IN BRACKETS [] ARE IN MILLIMETERS ROUNDED OFF TO THE NEAREST MILLIMETER, UNLESS OTHERWISE NOTED, AND ARE FOR REFERENCE ONLY.

TO ORDER BURNDY PRODUCTS CALL		NON-INSULATED BRAZED BARREL COPPER TERMINAL	
UNITED STATES		ITEM NO: 50002484	
1-800-346-4175 (LONDONDERRY, NH)		CAT. NO: YAD28M6E14	
CANADA:		DRAWN BY: T.BALAN 10/29/2012	
1-800-361-6975 (QUEBEC)		CHECKER: M.JEFF 11/29/2012	
1-800-387-6487 (ALL OTHER PROVINCES)		DSN APRVL: M.JEFF 11/29/2012	
FOR PRODUCT INFO: http://www.burndy.com		MFG APRVL: M.JEFF	
		QA APRVL: K.CHERYL 11/29/2012	
		MKT APRVL: G.STEWART 11/28/2012	
		PROJ #:	
		DRAWING NO	
		50013656	
		REV	
		A	
		SHEET 1 OF 1	