

CAT. NO.	WIRE RANGE	STUD SIZE [METRIC SIZE]	HYDRAULIC TOOLING					DIELESS TOOLING	NO. CRIMPS	WIRE STRIP LENGTH	REV	DATE	DESCRIPTION	ECO	BY	C'K.	
			DIE INDEX	TOOL CAT. NO.							B	8/19/2014	UPDATED AS PER MARKUP	37422	DK	MA	
YAD30M12E12	250-300 Kcmil STR.CU CODE & FLEX [120-150]mm ²	1/2" [12]	----	Y46, PAT46			Y750, PAT750		Y81KFT- SERIES PAT81KFT- SERIES Y4PC834- SERIES PAT4PC834- SERIES	1	1-1/8"						
				ADAPTOR	NEST	INDENTOR	NEST	INDENTOR									
				---	P44D	P48PR2	UM30N	UME									
				PUADP1	UM30N	UME											

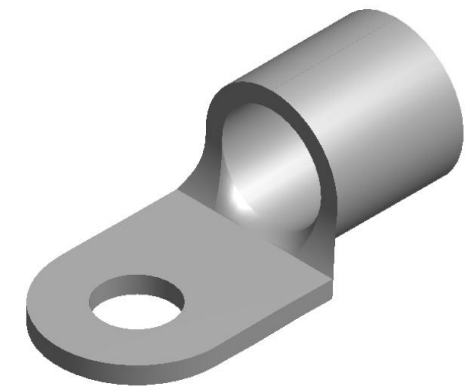
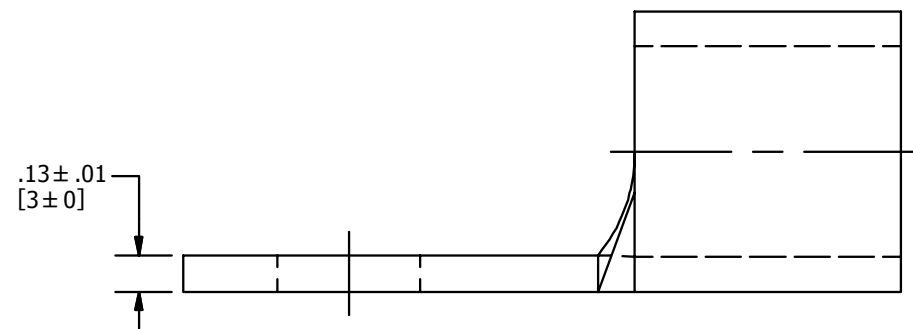
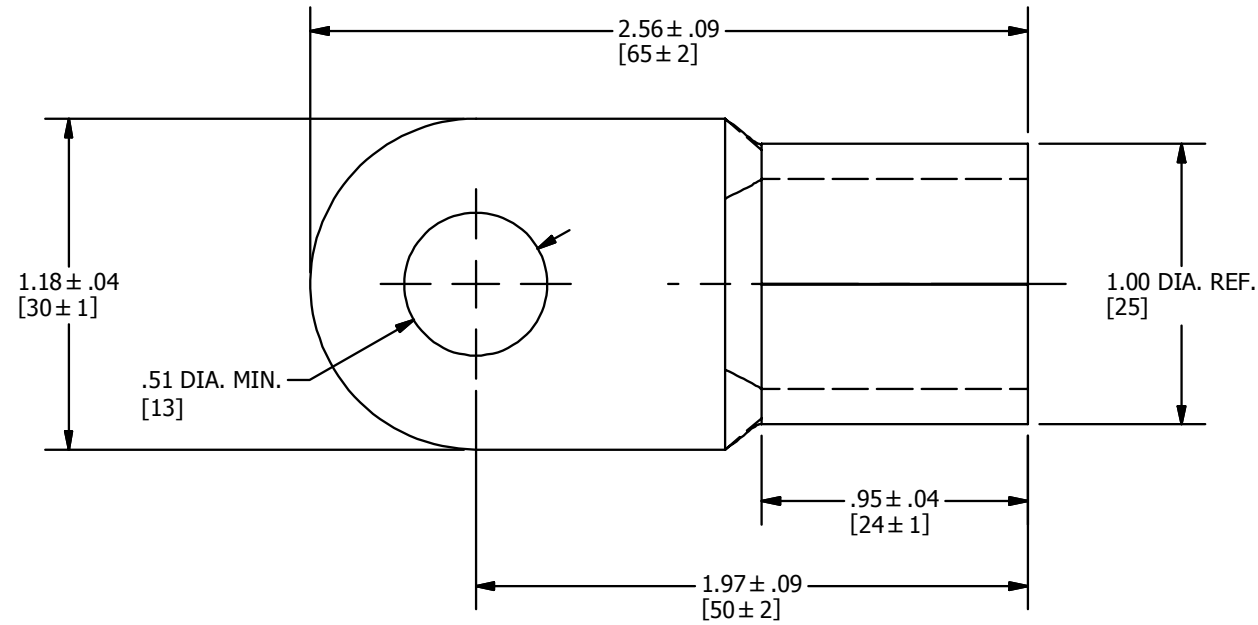

NOTES:

1. MATERIAL: COPPER.
2. FINISH: TIN PLATED.
3. Y35P3 ADAPTOR REQUIRED FOR P48PR2 INDENTORS IN Y46 AND PAT46 TOOLS.
4. DIMENSIONS IN BRACKETS [] ARE IN MILLIMETERS ROUNDED OFF TO THE NEAREST MILLIMETER, UNLESS OTHERWISE NOTED, AND ARE FOR REFERENCE ONLY.

TO ORDER BURNDY PRODUCTS CALL		NON-INSULATED BRAZED BARREL COPPER TERMINAL	
UNITED STATES		ITEM NO: 50002501	
1-800-346-4175 (LONDONDERRY, NH)		CAT. NO: YAD30M12E12	
CANADA:		DRAWN BY: T.BALAN 10/30/2012	
1-800-361-6975 (QUEBEC)		CHECKER: M.JEFF 11/29/2012	
1-800-387-6487 (ALL OTHER PROVINCES)		DSN APRVL: M.JEFF 11/29/2012	
FOR PRODUCT INFO: http://www.burndy.com		MFG APRVL: M.JEFF 11/29/2012	
		QA APRVL: K.CHERYL 11/29/2012	
		MKT APRVL: G.STEWART 11/28/2012	
		PROJ FAM:	
		DRAWING NO	
		50013664	
		REV	
		B	
		SHEET 1 OF 1	