

CONDUCTOR		BOLT SIZE	INSTALLATION TOOLING (# CRIMPS)								WIRE STRIP LENGTH	
FLEX	CODE (AWG)		DIE INDEX	COLOR CODE	MECHANICAL		HYDRAULIC			DIELESS (# OF CRIMPS)		
					MD7-34R	OUR840	BCT500 Y500CT	Y35, Y39, Y750, BAT35, BAT750	Y46 $\triangleleft$ 4			Y45 $\triangleleft$ 3
2/0 WELD 325/24	2/0 AWG (70MM <sup>2</sup> STR.)	3/8 [M10]	13	BLACK	$\triangleleft$ 6 W26RT (4) X26RT (4) W26VT (4)	$\triangleleft$ 6 X26RT (4) W26VT (4)	$\triangleleft$ 6 W26RT (4) X26RT (4) W26VT (4)	$\triangleleft$ 6 U26RT (2)	$\triangleleft$ 6 U26RT (2)	$\triangleleft$ 6 U26RT (2)	HYDRAULIC: Y644 (1) Y644M (1) Y644MBH (1)  MECHANICAL: MY29-11 (1)	1-9/16"

REV	DATE	DESCRIPTION	ECO	BY	C'H'K.
A	12/14/2012	DRAWING RELEASED	29802	HM	MA

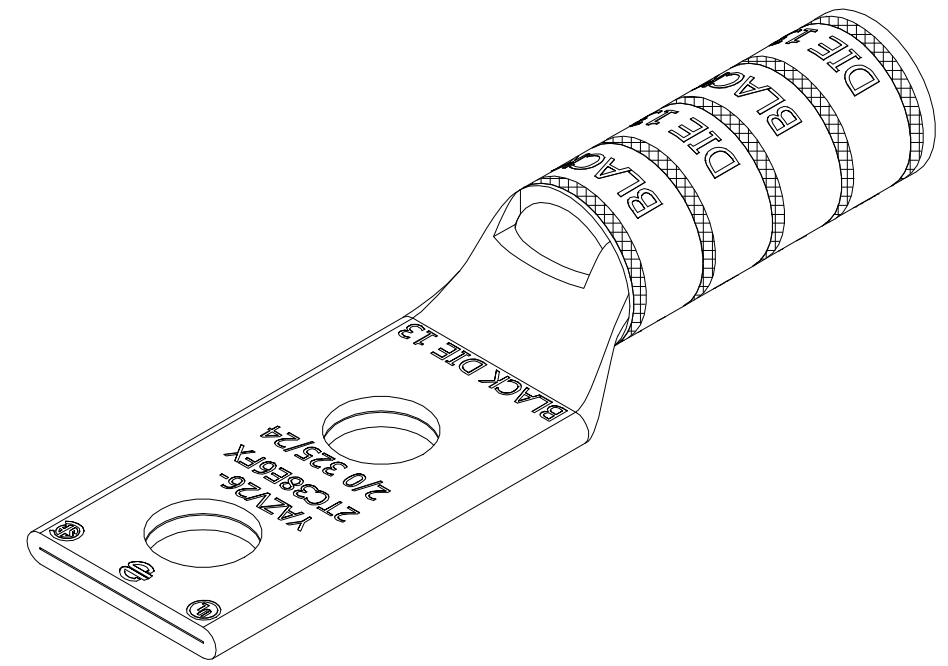
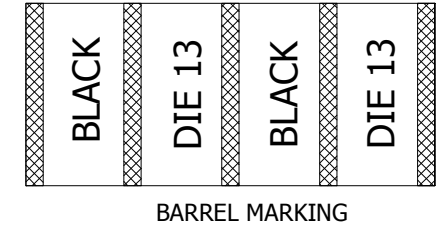
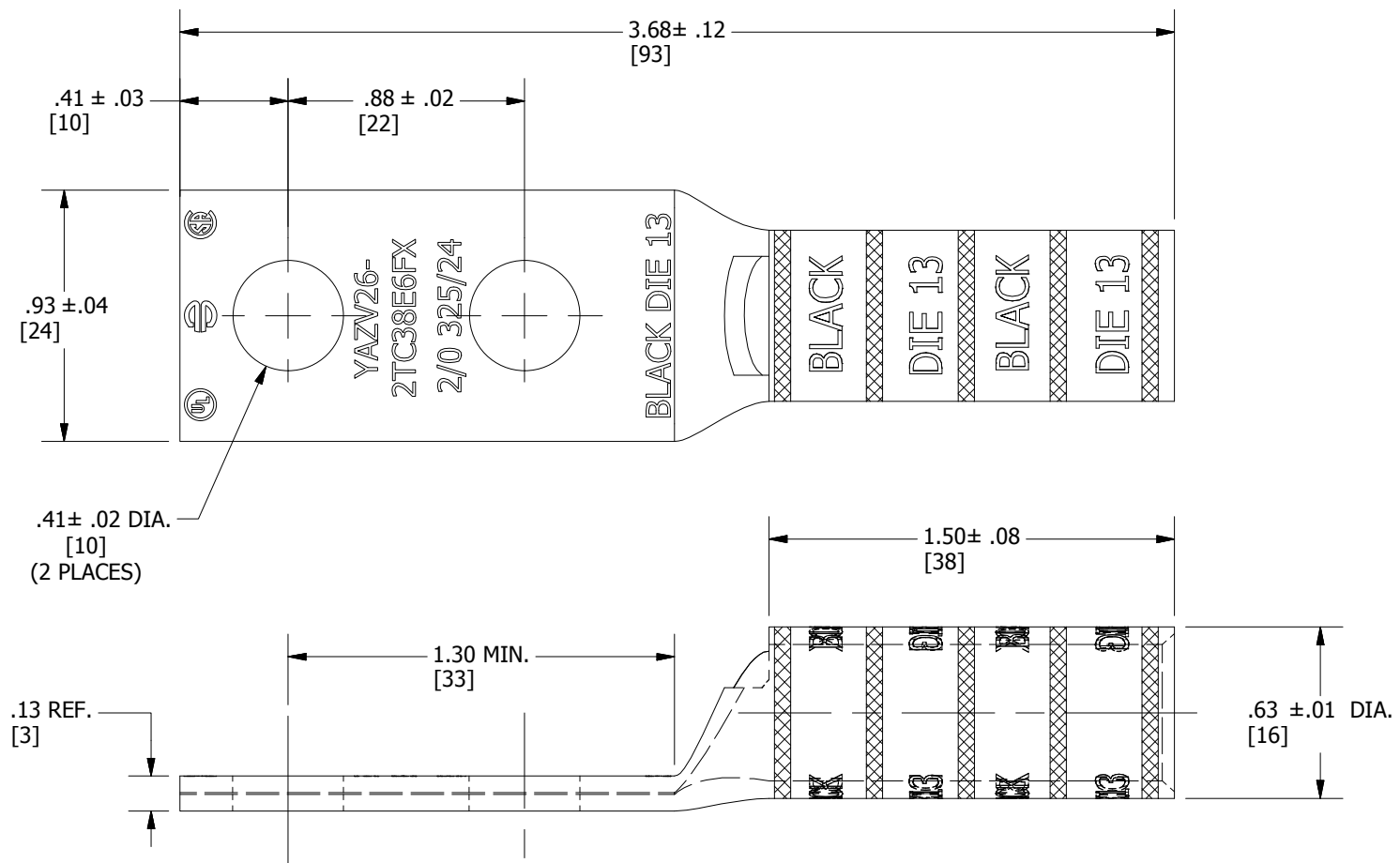

**NOTES:**

1. MATERIAL: COPPER TUBING.
2. FINISH: TIN PLATED.
3. CATALOG # PT6515 ADAPTOR IS REQUIRED TO USE "U" DIES IN Y45 SERIES TOOLS.
4. CATALOG # PUADP-1 ADAPTOR IS REQUIRED TO USE "U" DIES IN Y46 SERIES TOOLS.
5. DIMENSIONS IN BRACKETS [ ] ARE IN MILLIMETERS ROUNDED OFF TO THE NEAREST MILLIMETER, UNLESS OTHERWISE SPECIFIED AND ARE FOR REFERENCE ONLY.
6. CRIMP (# OF CRIMPS PER TABLE) WITHIN THE LENGTH BETWEEN THE INK STAMPED CRIMPING AREA.

TO ORDER BURNDY PRODUCTS CALL		HYLUG™ (TWO HOLE FLEX)	
UNITED STATES 1-800-346-4175 (LONDONDERRY, NH)		ITEM NO: 50013732	
CANADA: 1-800-361-6975 (QUEBEC) 1-800-387-6487 (ALL OTHER PROVINCES)		CAT. NO: YAZV262TC38E6FX	
FOR PRODUCT INFO: <a href="http://www.burndy.com">http://www.burndy.com</a>		DRAWN BY: M.PALANI 10/31/2012	
		CHECKER: J.MICHAUD 12/18/2012	
		DSN APRVL: D.FAN 12/18/2012	
		MFG APRVL: M.SMITH 12/18/2012	
		QA APRVL: T.WATTS 12/18/2012	
		MKT APRVL: J.SYLVIA 12/18/2012	
		PROD FAM: CM&R COMPRESSION	DRAWING NO
		PROJECT #: --	50013733
		DOCUMENT TYPE: SALES	REV
		REL LEVEL: Released	A
		SIZE	SHEET 1 OF 1
		B	