

CAT. NO.	WIRE RANGE	STUD SIZE [METRIC SIZE]	HYDRAULIC TOOLING					DIELESS TOOLING	NO. CRIMPS	WIRE STRIP LENGTH	
			DIE INDEX	TOOL CAT. NO.							
YAD31M20E34	300-350 Kcmil STR. CU CODE & FLEX [150-185]mm ²	3/4" [19]	----	Y46, PAT46			Y750, PAT750		Y81KFT- SERIES PAT81KFT- SERIES Y4PC834- SERIES PAT4PC834- SERIES	1	1-1/4"
				ADAPTOR	NEST	INDENTOR	NEST	INDENTOR			
				---	P44D	P48PR2	UM31N	UME			
				PUADP1	UM31N	UME					

REV	DATE	DESCRIPTION	ECO	BY	C'H'K.
B	8/19/2014	UPDATED AS PER MARKUP	37422	DK	MA

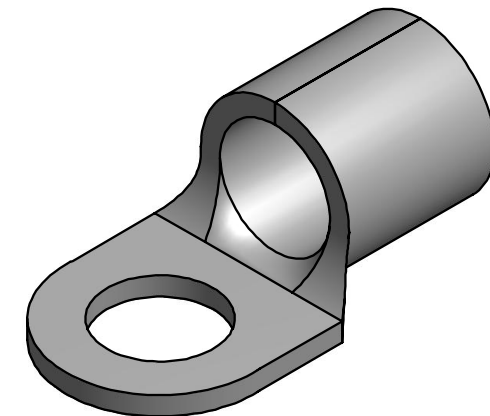
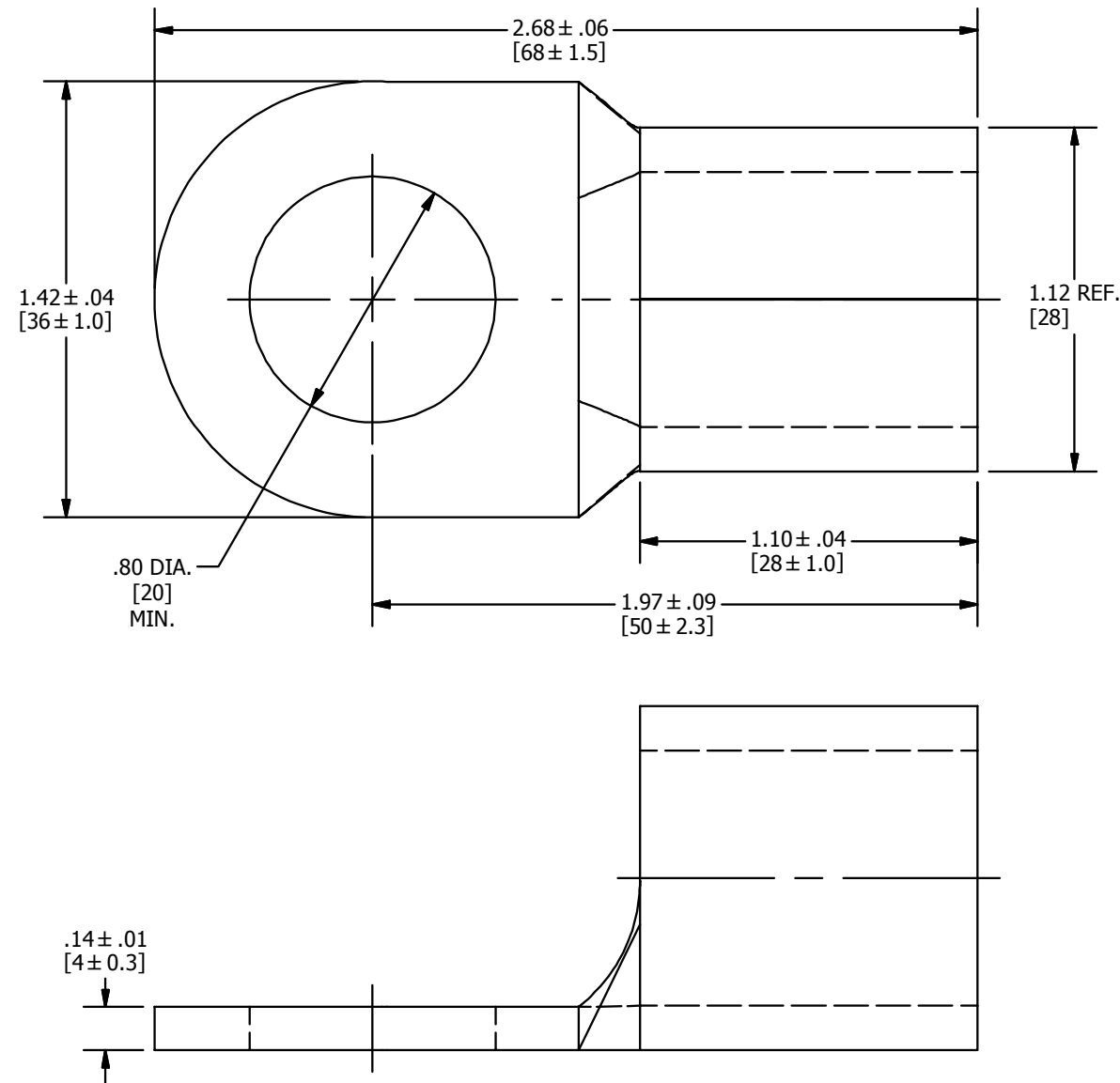

NOTES:

1. MATERIAL: COPPER.
2. FINISH: TIN PLATED.
3. DIMENSIONS IN BRACKETS [] ARE IN MILLIMETERS ROUNDED OFF TO THE NEAREST MILLIMETER, UNLESS OTHERWISE NOTED, AND ARE FOR REFERENCE ONLY.

4 USE 2 CRIMPS FOR DIELESS TOOLING.

TO ORDER BURNDY PRODUCTS CALL		NON-INSULATED BRAZED BARREL COPPER TERMINAL	
UNITED STATES		ITEM NO: 50002437	
1-800-346-4175 (LONDONDERRY, NH)		CAT. NO: YAD31M20E34	
CANADA:		DRAWN BY: V KAMAL 10/30/2012	
1-800-361-6975 (QUEBEC)		CHECKER: J MICHAUD 11/27/2012	
1-800-387-6487 (ALL OTHER PROVINCES)		DSN APRVL: J MICHAUD 11/27/12	
FOR PRODUCT INFO: http://www.burndy.com		MFG APRVL: --	
		QA APRVL: C KOWALCZYK 11/29/12	
		MKT APRVL: S GALE 11/21/12	
		PROJ FAMIL: --	
		PROJECT #: --	
		DOCUMENT TYPE: Sales	
		REL LEVEL: Released	
		SIZE	DRAWING NO
		B	50013872
			SHEET 1 OF 1
			REV
			B