

STRANDED COPPER CONDUCTOR ACCOMMODATED			BOLT SIZE	METRIC BOLT SIZE	COLOR CODE	DIE INFORMATION		MECHANICAL RATCHET						HYDRAULIC						DIELESS (# CRIMPS)	WIRE STRIP LENGTH
CODE (AWG)	NAVY	METRIC SIZE (CLASS 2)				DIE INDEX	TYPE	Y1MRTC	OUR840	MD6 MD7	MD6--R2 MD7-34R	PATMD6 PAT600	Y34A Y34B Y34BH	Y35, Y39 Y750, PAT750	Y46 PAT46	Y45	Y48B	Y60BHU			
250 kcmil	250	120MM ² STR [14.5]	1/2	M12	YELLOW	16	YELLOW DIE SET	----	X29RT (8)	W29VT (4)	W29RT (4) W29VT (4)	W29RT (4) W29VT (4)	A29R (2)	U29RT (2)	U29RT (2)	U29RT (2)	C29R(2)	L29RT(1)	MECHANICAL: MY29-3 (2), MY29 - 11(2) MRC - 840 (2) (4/0 ONLY)	1 - 11/16"	
							NEST	----	----	----	----	----	B29D (2) A29D (2) Y34PR	U29D-1 (2) Y34PR	U29D-1 (2) Y34PR	U29D-1 (2) Y34PR	C29D(1) Y48PR	----	HYDRAULIC: Y644 (1) PAT644 (1) Y81KFT - SERIES (2) Y4PC834 - SERIES (2)		
							INDENTOR	----	----	----	----	----									

REV	DATE	DESCRIPTION	ECO	BY	CHK
A	11/7/2012	NEW SALES DRAWING CREATED	29234	SS	MA

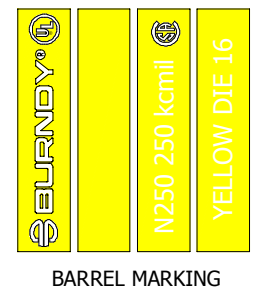

BARREL MARKING

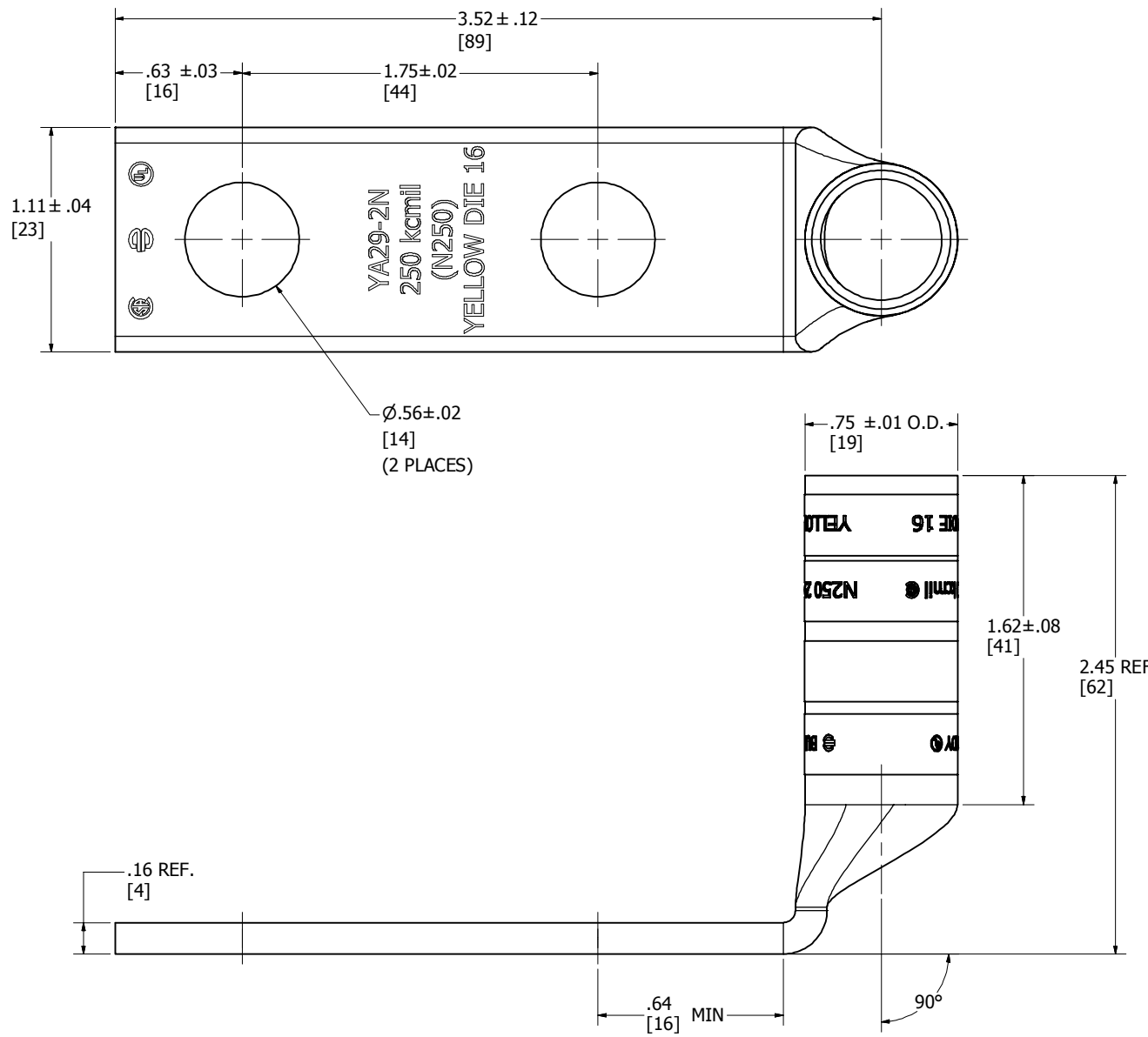
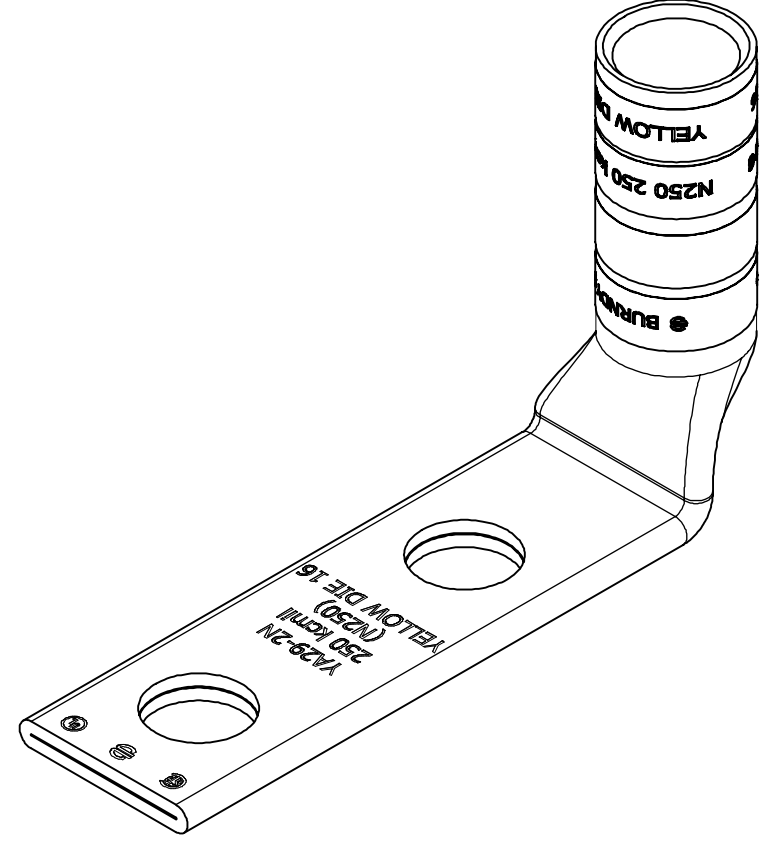

- NOTES:
1. MATERIAL: COPPER TUBING
 2. FINISH: TIN PLATED.
 3. CATALOG # PT6515 ADAPTOR IS REQUIRED TO USE "U" DIES IN Y45 SERIES TOOLS.
 4. CATALOG # PUADP-1 ADAPTOR IS REQUIRED TO USE "U" DIES IN Y46 SERIES TOOLS.
 5. Y35P3 INDENTOR ADAPTOR REQUIRED FOR Y34PR INDENTOR.
 6. PERMANENT DIE IN TOOLING.
 7. DIMENSIONS IN BRACKETS [] ARE IN MILLIMETERS ROUNDED OFF TO THE NEAREST MILLIMETER, UNLESS OTHERWISE NOTED, AND ARE FOR REFERENCE ONLY.
 8. FOR USE BY CUSTOMERS THAT HAVE THIS HYPRESS.™ NO NEW Y34A HYPRESS™ TOOLS ARE BEING PROCESSED. Y34A USES A--D TYPE NEST DIES.
 9. UL LISTED AND CSA CERTIFIED WIRE CONNECTOR.
 11. "X", "W-RT", "W-VT", "U", & "L" DIE SETS ARE COLOR CODED. "A", "B", AND "C" DIES ARE NOT COLOR CODED. NESTS AND INDENTOR TYPE ARE NOT COLOR CODED.

TO ORDER BURNDY® PRODUCTS CALL		HYLUG™													
UNITED STATES 1-800-346-4175 (LONDONDERRY, NH)		ITEM NO: 502857 CAT. NO: YA292N90													
CANADA: 1-800-361-6975 (QUEBEC) 1-800-387-6487 (ALL OTHER PROVINCES)		<table border="1"> <tr> <td>DRAWN BY: S.SRIRAM</td> <td>11/7/2012</td> </tr> <tr> <td>CHECKER: J. MICHAUD</td> <td>4/9/2013</td> </tr> <tr> <td>DSN APRVL: R. ROMAN</td> <td>3/17/2013</td> </tr> <tr> <td>MFG APRVL: M. KNAPTON</td> <td>2/28/2013</td> </tr> <tr> <td>QA APRVL: T. WATTS</td> <td>2/28/2013</td> </tr> <tr> <td>MKT APRVL: J. SYLVIA</td> <td>3/19/2013</td> </tr> </table>		DRAWN BY: S.SRIRAM	11/7/2012	CHECKER: J. MICHAUD	4/9/2013	DSN APRVL: R. ROMAN	3/17/2013	MFG APRVL: M. KNAPTON	2/28/2013	QA APRVL: T. WATTS	2/28/2013	MKT APRVL: J. SYLVIA	3/19/2013
DRAWN BY: S.SRIRAM	11/7/2012														
CHECKER: J. MICHAUD	4/9/2013														
DSN APRVL: R. ROMAN	3/17/2013														
MFG APRVL: M. KNAPTON	2/28/2013														
QA APRVL: T. WATTS	2/28/2013														
MKT APRVL: J. SYLVIA	3/19/2013														
FOR PRODUCT INFO: http://www.burndy.com		<table border="1"> <tr> <td>PROJ #:</td> <td>---</td> <td>SIZE:</td> <td>D</td> </tr> <tr> <td>DOCUMENT TYPE:</td> <td>SALES</td> <td>DRAWING NO:</td> <td>50013990</td> </tr> <tr> <td>REL LEVEL:</td> <td>Released</td> <td>REV:</td> <td>A</td> </tr> </table>		PROJ #:	---	SIZE:	D	DOCUMENT TYPE:	SALES	DRAWING NO:	50013990	REL LEVEL:	Released	REV:	A
PROJ #:	---	SIZE:	D												
DOCUMENT TYPE:	SALES	DRAWING NO:	50013990												
REL LEVEL:	Released	REV:	A												