

STRANDED COPPER CONDUCTOR ACCOMMODATED			BOLT SIZE	METRIC BOLT SIZE	COLOR CODE	DIE INFORMATION		MECHANICAL					HYDRAULIC					DIELESS (# CRIMPS)	WIRE STRIP LENGTH		
CODE (AWG)	NAVY	METRIC SIZE (CLASS 2)				DIE INDEX	TYPE	Y1MRTC	OUR840	MD6 MD7	MD6--R2 MD7-34R	PAT600 Y500	Y34A Y34B Y34BH	Y35, Y39<4> Y750, PAT750	Y46 PAT46	Y45	Y48B			Y60BHU	
650 kcmil	----	----	1/2	M12	ORANGE	23	ORANGE DIE SET	----	----	----	----	----	----	U37RT (4)	U37RT (4)	U37RT (4)	C37R (2)	L37RT (2)	HYDRAULIC: Y644 (1) PAT644 (1) PAT81KFT (4) Y4PC834 (4) PAT4PC834 (4)	2 - 7/8"	
							NEST	----	----	----	----	----	----	P37D (2) P44PR	----	----	C37D (2) Y48PR	----			
							INDENTOR	----	----	----	----	----	----								

REV	DATE	DESCRIPTION	ECO	BY	CHK.
A	11/14/2012	NEW SALES DRAWING CREATED	29385	HM	MA

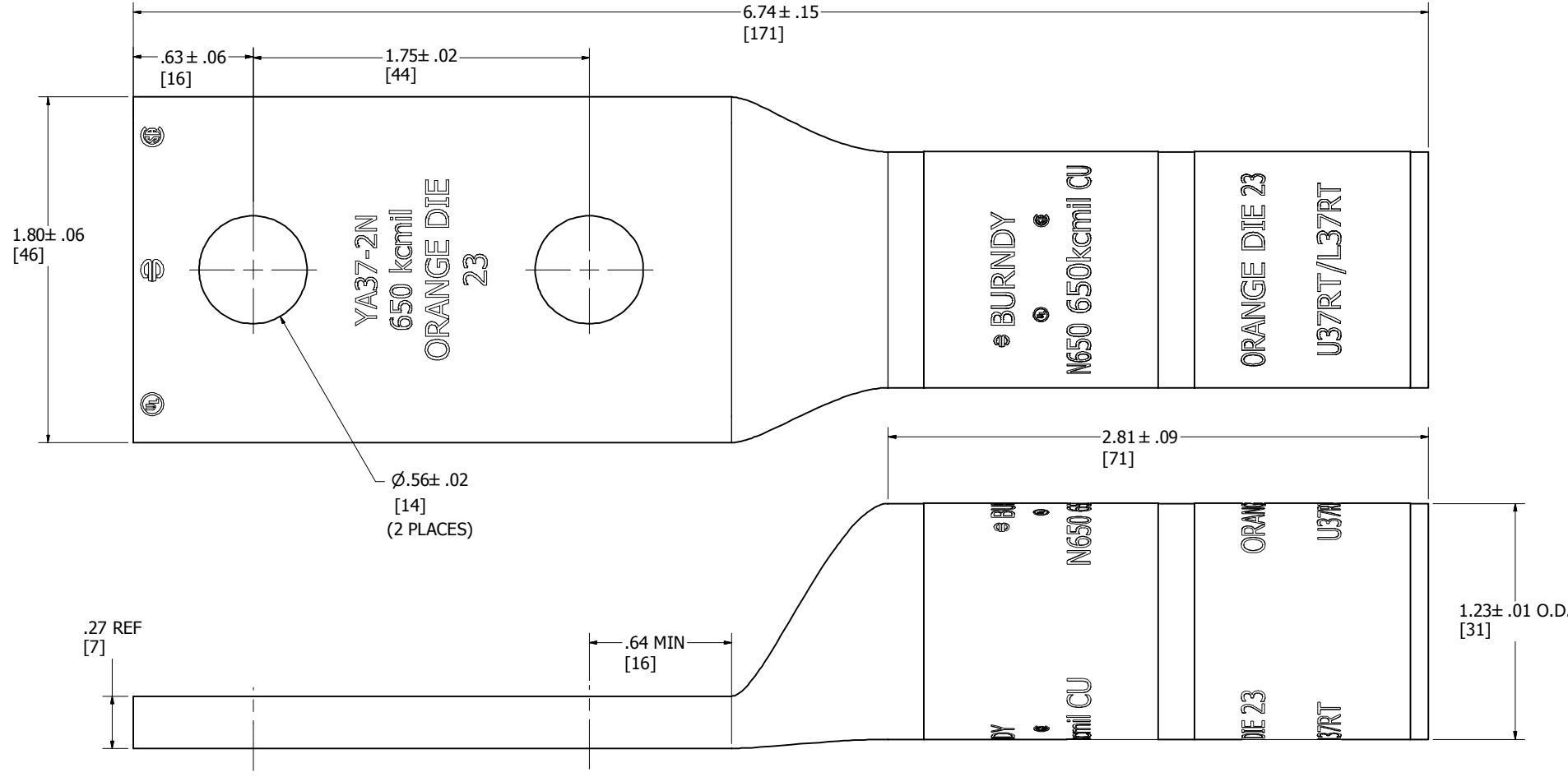

BARREL MARKING

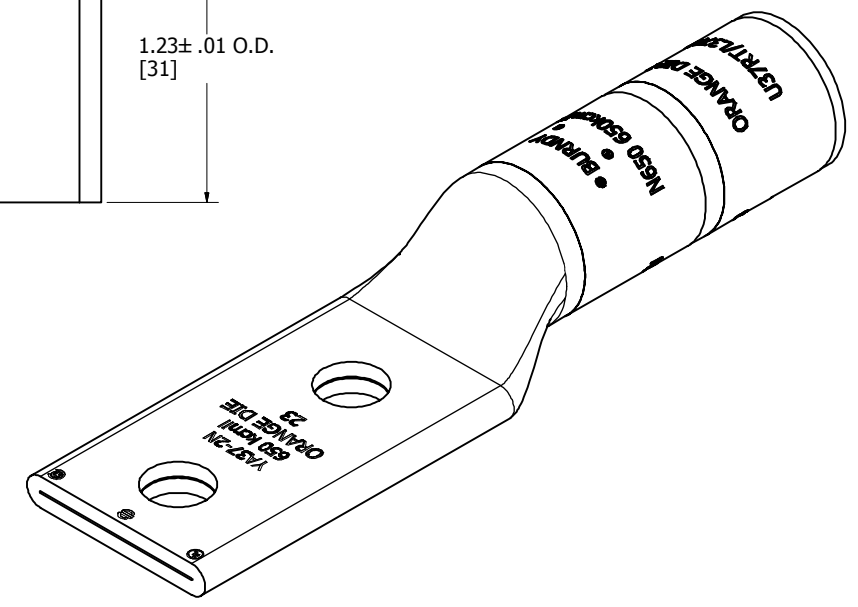

NOTES:

- MATERIAL: COPPER TUBING
- FINISH: TIN PLATED.
- CATALOG # PT6515 ADAPTOR IS REQUIRED TO USE "U" DIES IN Y45 SERIES TOOLS.
- CATALOG # PUADP-1 ADAPTOR IS REQUIRED TO USE "U" DIES IN Y46 SERIES TOOLS.
- PERMANENT DIE IN TOOLING.
- DIMENSIONS IN BRACKETS [] ARE IN MILLIMETERS ROUNDED OFF TO THE NEAREST MILLIMETER, UNLESS OTHERWISE NOTED, AND ARE FOR REFERENCE ONLY.
- FOR USE BY CUSTOMERS THAT HAVE THIS HYPRESS.™ NO NEW Y34A HYPRESS™ TOOLS ARE BEING PROCESSED. Y34A USES A--D TYPE NEST DIES.
- UL LISTED AND DCSA CERTIFIED WIRE CONNECTOR.
- "X", "W-RT", "W-VT", "U", & "L" DIE SETS ARE COLOR CODED. "A", "B", AND "C" DIES ARE NOT COLOR CODED. NESTS AND INDENTOR TYPE ARE NOT COLOR CODED.

TO ORDER BURNDY® PRODUCTS CALL		HYLUG™	
UNITED STATES 1-800-346-4175 (LONDONDERRY, NH)		ITEM NO: 510057	
CANADA: 1-800-361-6975 (QUEBEC) 1-800-387-6487 (ALL OTHER PROVINCES)		CAT. NO: YA372N	
FOR PRODUCT INFO: http://www.burndy.com		DRAWN BY: HMALHOTRA 11/14/2012	
		CHECKER: J. MICHAUD 4/9/2013	
		DSN APRVL: R. ROMAN 3/2/2013	
		MFG APRVL: M. KNAPTON 2/12/2013	
		QA APRVL: T. WATTS 1/23/2013	
		MKT APRVL: J. SYLVIA 3/25/2013	
		PROD FAM: CM&R COMPRESSION	
		DRAWING NO	
		50014594	
		REV	
		A	
		SHEET 1 OF 1	