

STRANDED COPPER CONDUCTOR ACCOMMODATED			BOLT SIZE	METRIC BOLT SIZE	COLOR CODE	DIE INFORMATION		INSTALLATION TOOLING (# OF CRIMPS)				DIELESS (# CRIMPS)	WIRE STRIP LENGTH
CODE (AWG)	NAVY	METRIC SIZE (CLASS 2)				DIE INDEX	TYPE	Y35, Y39 Y750, PAT750	PAT46 Y46	Y45	Y60BHU		
750 Kcmil	-----	375mm <sup>2</sup> STR	1/2	M12	BLACK	24	BLACK DIE SET	U39RT (4)	U39RT (4) P39RT (4)	U39RT (4) S39RT (4)	L39RT (2) L36ART (2)	HYDRAULIC: Y644 (1) PAT644 (1) Y81KFT (4) PAT81KFT (4)	2-15/16"
							NEST INDENTOR	----	P39D (2) P44PR	----	----		

REV	DATE	DESCRIPTION	ECO	BY	C'H'K.
B	03/06/2015	TONGUE MARKING UPDATED AND REMOVE TOOLING AND ASSOCIATED NOTES	39386	DD	RM

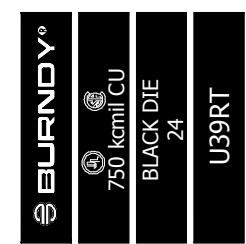

BARREL MARKING

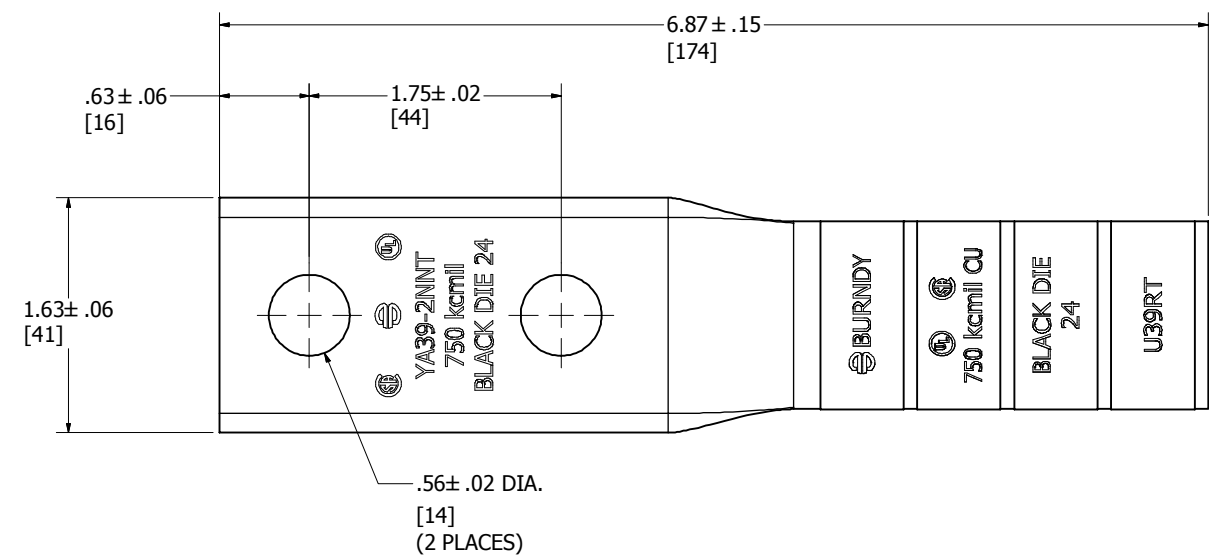
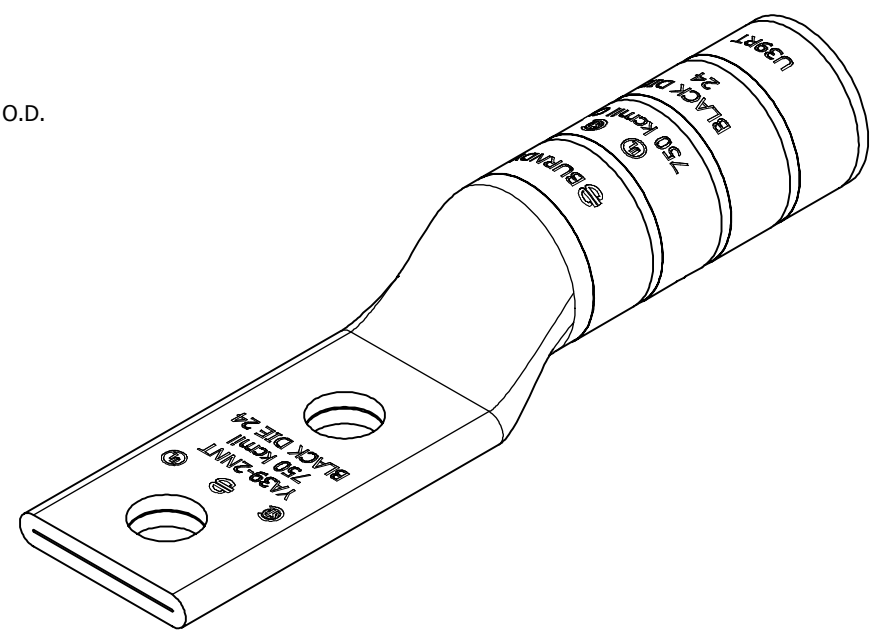
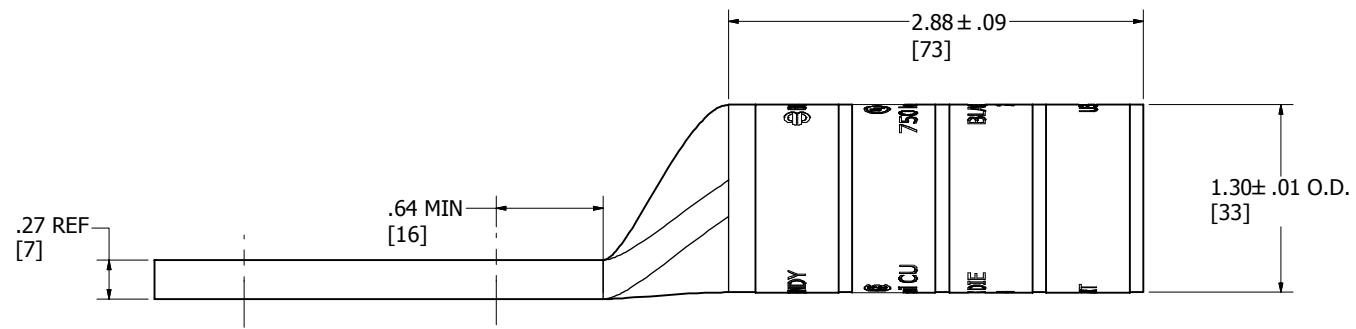

NOTES:

1. MATERIAL: COPPER TUBING.
2. FINISH: TIN PLATED.
3. CATALOG # PT6515 ADAPTOR IS REQUIRED TO USE "U" DIES IN Y45 SERIES TOOLS.
4. CATALOG # PUADP-1 ADAPTOR IS REQUIRED TO USE "U" DIES IN Y46 SERIES TOOLS.
5. DIMENSIONS IN BRACKETS [ ] ARE IN MILLIMETERS ROUNDED OFF TO THE NEAREST MILLIMETER, UNLESS OTHERWISE NOTED, AND ARE FOR REFERENCE ONLY.
6. UL LISTED AND CSA CERTIFIED WIRE CONNECTORS.
7. "U" & "L" DIE SETS ARE COLOR CODED. NEST AND INDENTOR TYPE ARE NOT COLOR CODED.

TO ORDER BURNDY® PRODUCTS CALL		HYLUG™	
UNITED STATES 1-800-346-4175 (LONDONDERRY, NH)		ITEM NO: 25022034	
CANADA: 1-800-361-6975 (QUEBEC) 1-800-387-6487 (ALL OTHER PROVINCES)		CAT. NO: YA392NNT	
FOR PRODUCT INFO: <a href="http://www.burndy.com">http://www.burndy.com</a>		DRAWN BY: GANESAN 11/20/2012	
		CHECKER: J.MICHAUD 5/2/2013	
		DSN APRVL: R.ROMAN 4/26/2013	
		MFG APRVL: M.KNAPTON 4/26/2013	
		QA APRVL: T.WATTS 4/29/2013	
		MKT APRVL: J.SYLVIA 4/25/2013	
		PROD FAM: CM&R COMPRESSION	
		DRAWING NO	
		50015001	
		REV	
		B	
		SHEET 1 OF 1	