

REV	DATE	DESCRIPTION	ECO	BY	CHK.
C	03/04/2020	UPDATED AS PER MARKUP	53139	YR	SS

CATALOG NO.	STRANDED COPPER CONDUCTOR ACCOMMODATED AWG	BOLT SIZE [METRIC]	DIMENSIONS				INSTALLATION TOOLING (# CRIMPS)						DIELESS (# CRIMPS)	WIRE STRIP LENGTH		
			K DIA.	L	N	Z MIN	COLOR CODE	DIE INDEX	MECHANICAL		HYDRAULIC					
									OUR840	MD7-34R	BCT500 Y500CT	Y35, Y39, Y750 PAT750			Y46 \triangleleft 4	Y45 \triangleleft 3
YAZV27TC38FXB	3/0 CLASS B, C, D, G, H, I, K, M DLO (450/240)	3/8 [M10]	.41	2.98	.41	.42	ORANGE	14	X27RT (4)	W27RT (4) X27RT (4) W27VT (4)	W27RT (4) X27RT (4) W27VT (4)	U27RT (2)	U27RT (2)	U27RT (2)	MECHANICAL: MY29-11 (2) HYDRAULIC: Y644 (1) PAT644 (1) Y81KFT (2) PAT81KFT (2)	1-9/16"
YAZV27TC516FXB		5/16 [M8]	.33	2.85	.34	.36										
YAZV27TC12FXB		1/2 [M12]	.53	3.23	.53	.55										

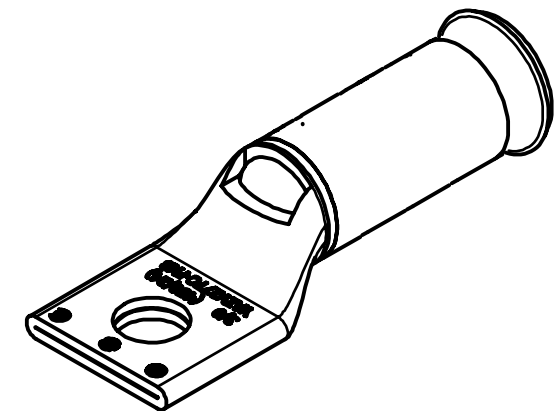
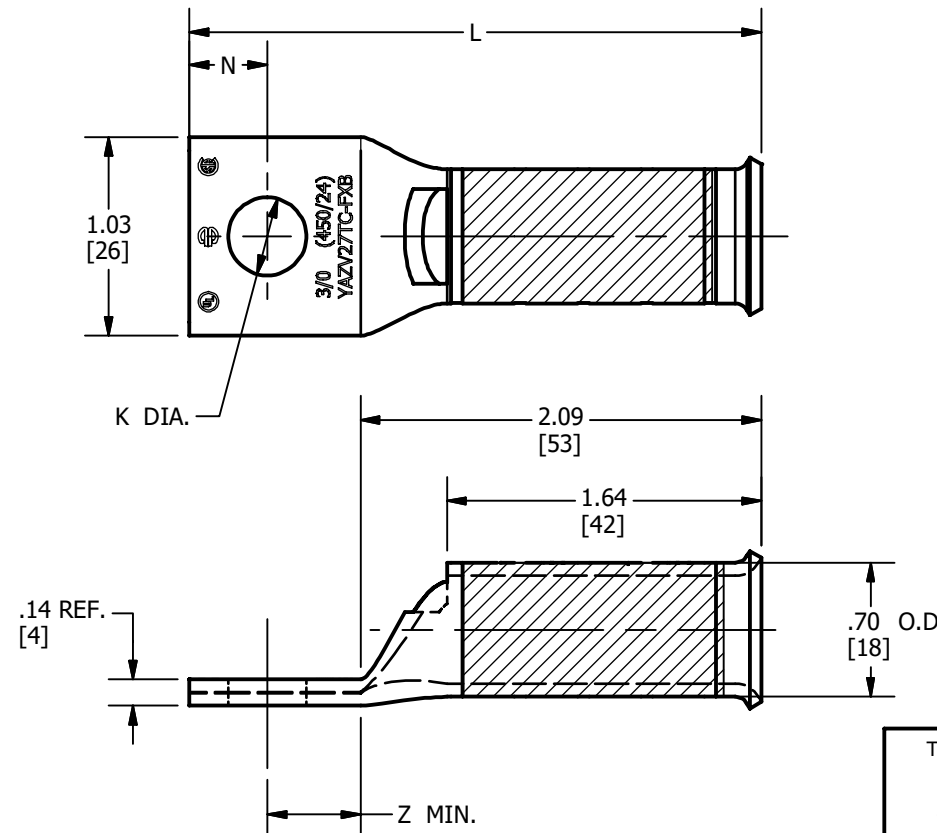

NOTES:

1. MATERIAL: COPPER TUBING.
2. FINISH: ELECTRO TIN PLATED.
3. CATALOG # PT6515 ADAPTOR IS REQUIRED TO USE "U" DIES IN Y45 SERIES TOOLS.
4. CATALOG # PUADP-1 ADAPTOR IS REQUIRED TO USE "U" DIES IN Y46 SERIES TOOLS.
5. DIMENSIONS IN BRACKETS [] ARE IN MILLIMETERS ROUNDED OFF TO THE NEAREST MILLIMETER, UNLESS OTHERWISE NOTED, AND ARE FOR REFERENCE ONLY.
6. UL LISTED AND CSA CERTIFIED WIRE CONNECTORS.

TO ORDER BURNDY PRODUCTS CALL
 UNITED STATES
 1-800-346-4175 (LONDONDERRY, NH)
 CANADA:
 1-800-361-6975 (QUEBEC)
 1-800-387-6487 (ALL OTHER PROVINCES)
 FOR PRODUCT INFO: <http://www.burndy.com>

HYLUG™ BELLED 3/0 FLEX (450/24)	
ITEM NO: SEE TABLE	
CAT. NO: SEE TABLE	
DRAWN BY: M.PALANI 11/26/2012	
CHECKER: --	
DSN APRVL: R.ROMAN 05/06/2014	
MFG APRVL: --	
QA APRVL: T.WATTS 07/26/2013	
MKT APRVL: M.BAILLY 07/31/2013	
PROD FAM: CM&R COMPRESSION	DRAWING NO
PROJECT #: --	50015347
DOCUMENT TYPE: SALES	REV
REL LEVEL: Released	C