

FINISHED CATALOG NUMBER	WITHOUT PB CATALOG NUMBER	CONNECTOR QUANTITY PER BOX	BOX SIZE INSIDE DIMENSIONS LENGTH X WIDTH X HEIGHT	POWER BOOSTER CATALOG NUMBER
WSL1PB	WSL1	5	12.63 X 6.38 X 4.88	WPBY-A 5 PER BOX
WSL2PB	WSL2			
WSL3PB	WSL3			
WSL4PB	WSL4			
WSL5PB	WSL5			
WSL6PB	WSL6			
WSL7PB	WSL7			
WSL8PB	WSL8			
WSL10PB	WSL10			
WSL12PB	WSL12			
WSL13PB	WSL13			

REV	DATE	DESCRIPTION	ECO	BY	C'H'K.
A	11/22/2012	DRAWING RELEASED	29217	PR	MB

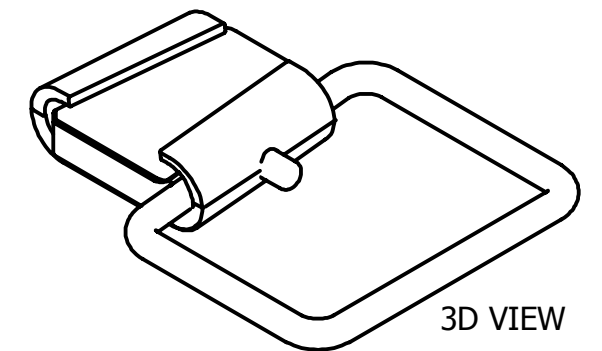
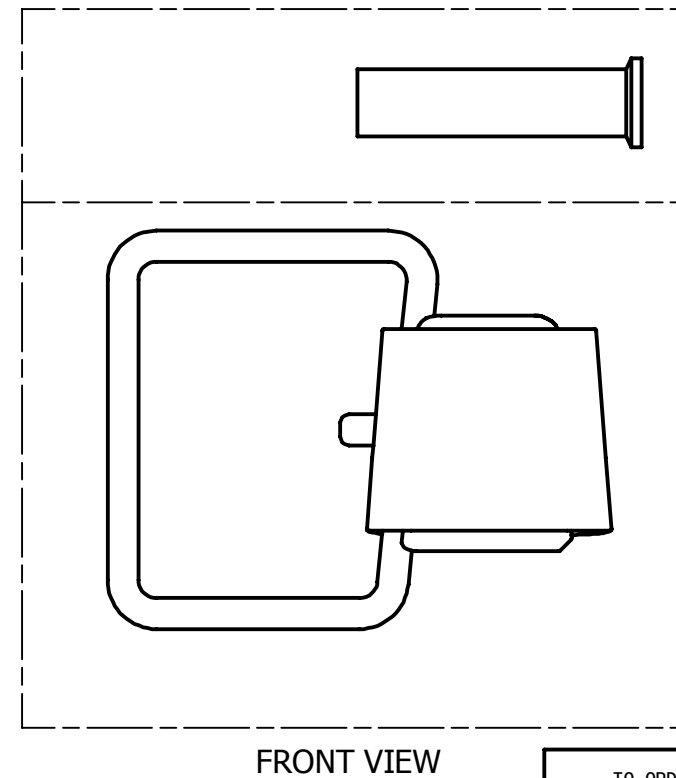
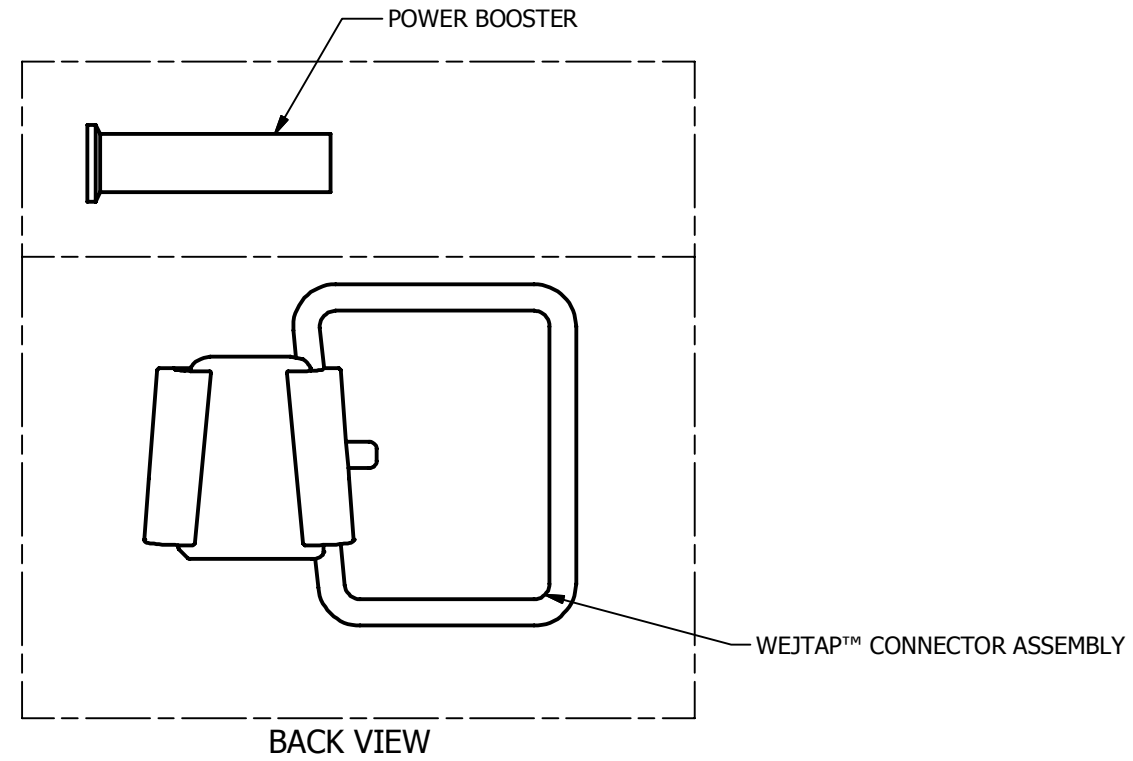

**NOTES:**

- EACH CONNECTOR TO BE LABELED SO AS NOT TO PREVENT INSPECTION OF WEDGE IDENTIFICATION STAMP AND COLOR .
- ORM-D WARNING LABEL QUANTITY = 1 PER CARTON.

TO ORDER BURNDY® PRODUCTS CALL  
 UNITED STATES  
 1-800-346-4175 (LONDONDERRY, NH)  
 CANADA:  
 1-800-361-6975 (QUEBEC)  
 1-800-387-6487 (ALL OTHER PROVINCES)  
 FOR PRODUCT INFO: <http://www.burndy.com>

WEJTAP CONNECTOR WITH POWER BOOSTER ASSEMBLY			
ITEM NO: --			
CAT. NO: WSL--PB (SEE TABLE)			
DRAWN BY: YPADMARAJA	11/22/2012		
CHECKER: G SCHRADER	10/17/2013		
DSN APRVL: G SCHRADER	10/17/2013		
MFG APRVL: F CHISOLM	7/24/2013		
QA APRVL: --	--		
MKT APRVL: B CRUTCHER	8/29/2013		
PROD FAM: --	--	DRAWING NO	REV
PROJECT #: --	SIZE	50015351	A
DOCUMENT TYPE: SALES	B	SHEET 1 OF 3	
REL LEVEL: Released			

FINISHED CATALOG NUMBER	WITHOUT PB CATALOG NUMBER	CONNECTOR QUANTITY PER BOX	BOX SIZE INSIDE DIMENSIONS LENGTH X WIDTH X HEIGHT	POWER BOOSTER CATALOG NUMBER
WSM1PB	WSM1	10	6.88 X 5.88 X 6.38	WPBB-A 10 PER BOX
WSM2PB	WSM2			
WSM3PB	WSM3			
WSM4PB	WSM4			
WSM7PB	WSM7			

REV	DATE	DESCRIPTION	ECO	BY	C'H'K.
A	11/22/2012	DRAWING RELEASED	29217	PR	MB

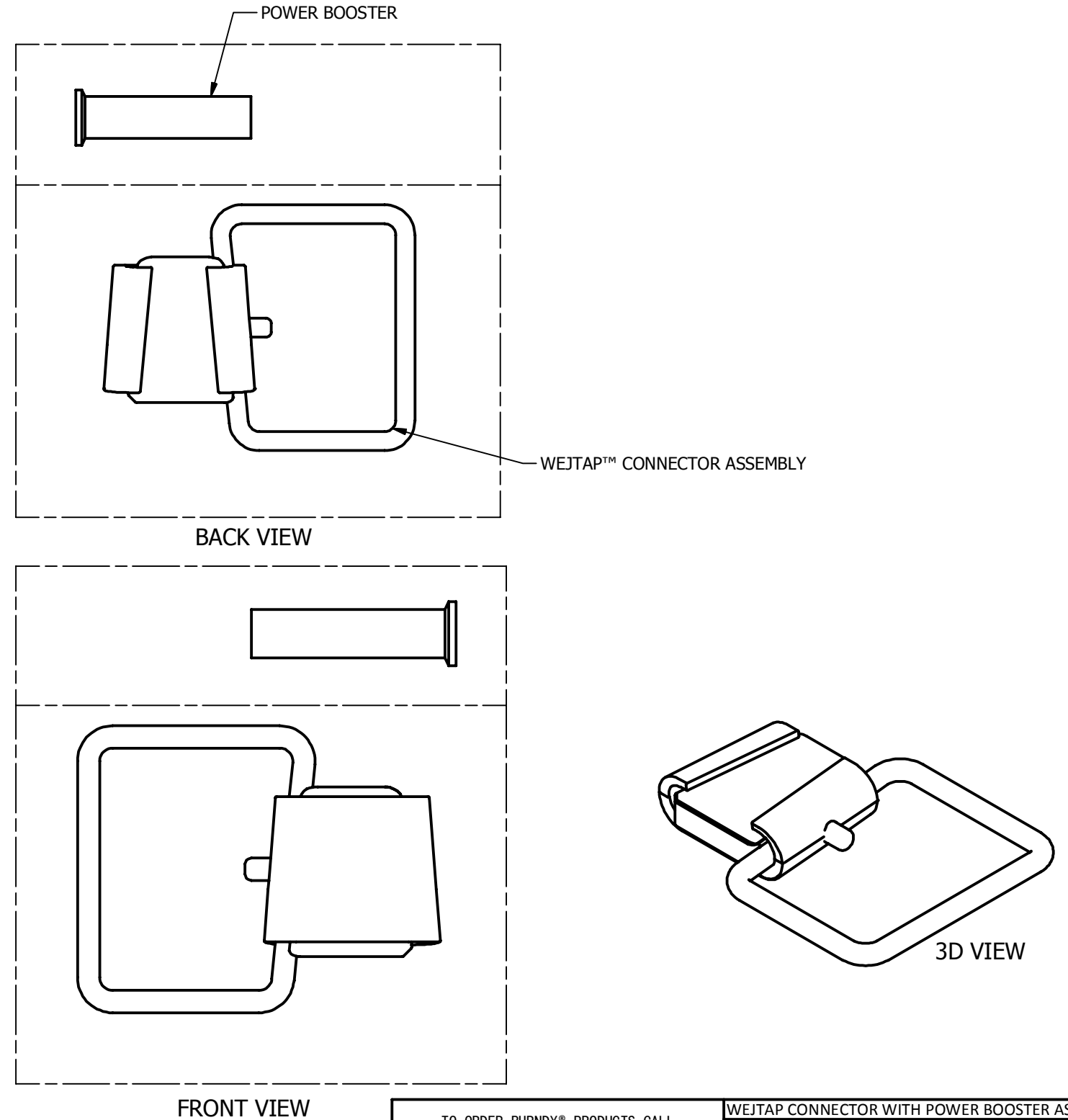

**NOTES:**

1. EACH CONNECTOR TO BE LABELED SO AS NOT TO PREVENT INSPECTION OF WEDGE IDENTIFICATION STAMP AND COLOR .
2. ORM-D WARNING LABEL QUANTITY = 1 PER CARTON.

TO ORDER BURNDY® PRODUCTS CALL		WEJTAP CONNECTOR WITH POWER BOOSTER ASSEMBLY	
UNITED STATES 1-800-346-4175 (LONDONDERRY, NH)		ITEM NO: --	
CANADA: 1-800-361-6975 (QUEBEC) 1-800-387-6487 (ALL OTHER PROVINCES)		CAT. NO: WSM--PB (SEE TABLE)	
FOR PRODUCT INFO: <a href="http://www.burndy.com">http://www.burndy.com</a>		DRAWN BY: YPADMARAJA 11/22/2012	
		CHECKER: G SCHRADER 10/17/2013	
		DSN APRVL: G SCHRADER 10/17/2013	
		MFG APRVL: F CHISOLM 7/24/2013	
		QA APRVL: --	
		MKT APRVL: B CRUTCHER 8/29/2013	
		PROD FAM: --	
		DRAWING NO	
		50015351	
		REV	
		A	
		SHEET 2 OF 3	

FINISHED CATALOG NUMBER	WITHOUT PB CATALOG NUMBER	CONNECTOR QUANTITY PER BOX	BOX SIZE INSIDE DIMENSIONS LENGTH X WIDTH X HEIGHT	POWER BOOSTER CATALOG NUMBER
WSS1PB	WSS1	10	6.88 X 5.88 X 6.38	WPBR-A 10 PER BOX
WSS2PB	WSS2			

REV	DATE	DESCRIPTION	ECO	BY	C'H'K.
A	11/22/2012	DRAWING RELEASED	29217	PR	MB

POWER BOOSTER

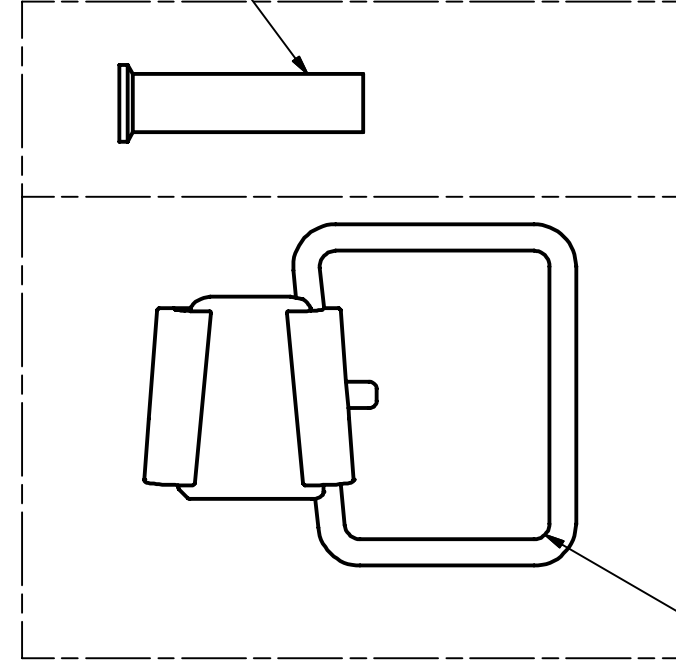

BACK VIEW

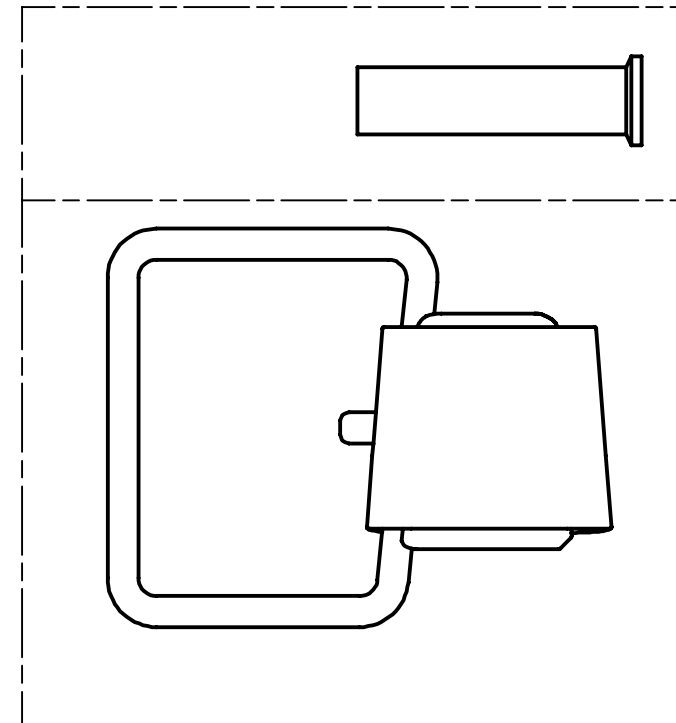

FRONT VIEW

WEJTAP™ CONNECTOR ASSEMBLY

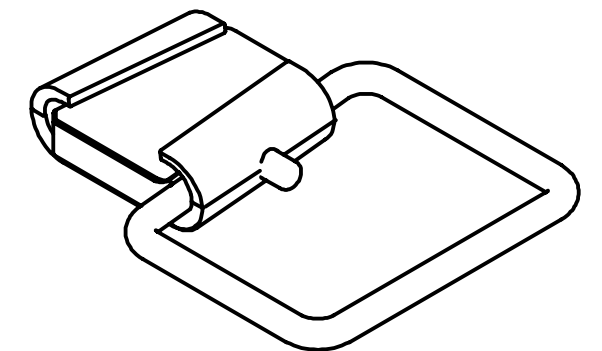

3D VIEW

**NOTES:**

- EACH CONNECTOR TO BE LABELED SO AS NOT TO PREVENT INSPECTION OF WEDGE IDENTIFICATION STAMP AND COLOR .
- ORM-D WARNING LABEL QUANTITY = 1 PER CARTON.

TO ORDER BURNDY® PRODUCTS CALL  
 UNITED STATES  
 1-800-346-4175 (LONDONDERRY, NH)  
 CANADA:  
 1-800-361-6975 (QUEBEC)  
 1-800-387-6487 (ALL OTHER PROVINCES)  
 FOR PRODUCT INFO: <http://www.burndy.com>

WEJTAP CONNECTOR WITH POWER BOOSTER ASSEMBLY	
ITEM NO: --	
CAT. NO: WSS--PB (SEE TABLE)	
DRAWN BY: YPADMARAJA 11/22/2012	
CHECKER: G SCHRADER 10/17/2013	
DSN APRVL: G SCHRADER 10/17/2013	
MFG APRVL: F CHISOLM 7/24/2013	
QA APRVL: --	
MKT APRVL: B CRUTCHER 8/29/2013	
PROD FAM: --	
PROJECT #: --	
DOCUMENT TYPE: SALES	
REL LEVEL: Released	
DRAWING NO	REV
50015351	A
SIZE	
B	
SHEET 3 OF 3	

