

STRANDED COPPER CONDUCTOR ACCOMMODATED		BOLT SIZE	INSTALLATION TOOLING (# CRIMPS)											REV	DATE	DESCRIPTION	ECO	BY	C'H'K.		
AWG	NAVY		COLOR CODE	DIE INDEX	MECHANICAL				HYDRAULIC					DIELESS (# CRIMPS)	WIRE STRIP LENGTH	A	11/26/2012	SALES DWG. FOR CAT# YAZV26TC38FXB	29531	PM	MB
					Y1MRTC	OUR840	MD6 MD7	MD6--R2 MD7-34R	Y500CT PATMD6 PAT600	Y34A Y34B Y34BH	Y35, Y39, Y750 PAT750	Y46 PAT46	Y45								
2/0 CLASS B, C, D, G, H, I, K, M DLO (450/240) 70mm ² CLASS 2	--	3/8 [M10]	BLACK	13	--	X26RT (4) W26VT (4)	--	W26RT (4) X26RT (4) W26VT (4)	W26RT (4) X26RT (4) W26VT (4)	--	U26RT (2)	U26RT (2)	U26RT (2)	MECHANICAL: MY29-11 (1) HYDRAULIC: Y644 (1) PAT644 (1) Y81KFT (2) PAT81KFT (2)	1-9/16"						

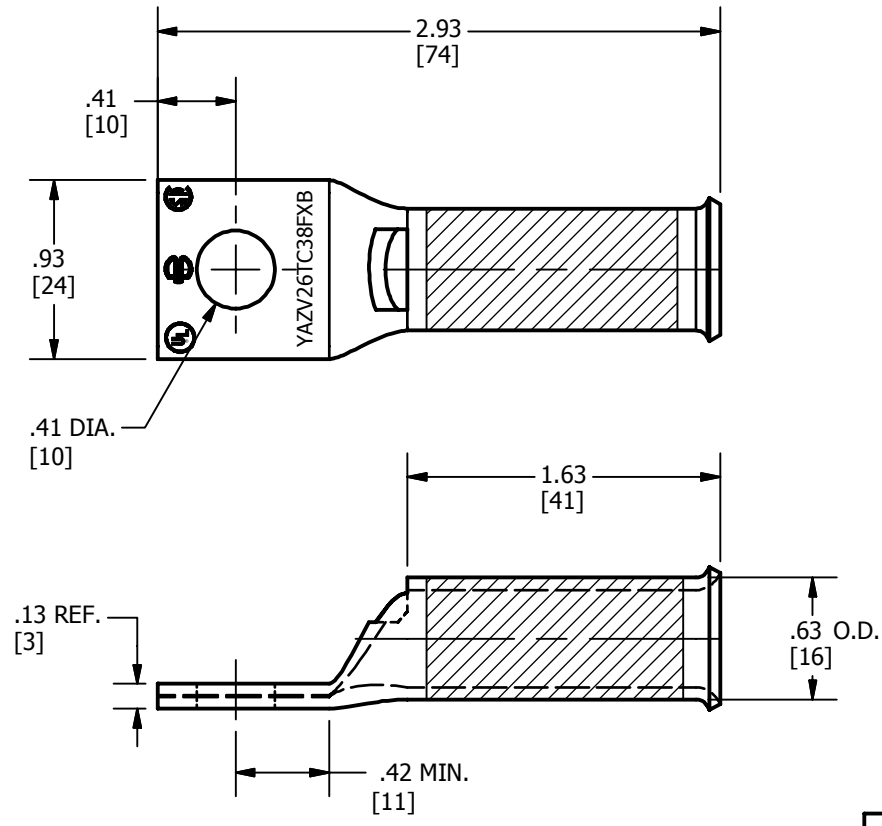

NOTES:

1. MATERIAL: COPPER TUBING.
2. FINISH: ELECTRO TIN PLATED.
3. CATALOG # PT6515 ADAPTOR IS REQUIRED TO USE "U" DIES IN Y45 SERIES TOOLS.
4. CATALOG # PUADP-1 ADAPTOR IS REQUIRED TO USE "U" DIES IN Y46 SERIES TOOLS.
5. Y35P3 INDENTOR ADAPTOR REQUIRED FOR Y34PR INDENTOR.
6. DIMENSIONS IN BRACKETS [] ARE IN MILLIMETERS ROUNDED OFF TO THE NEAREST MILLIMETER, UNLESS OTHERWISE NOTED, AND ARE FOR REFERENCE ONLY.
7. UL LISTED AND CSA CERTIFIED WIRE CONNECTORS.

TO ORDER BURNDY PRODUCTS CALL		HYLUG™ BELLED 2/0 FLEX (325/24)	
UNITED STATES		ITEM NO: 10061488	
1-800-346-4175 (LONDONDERRY, NH)		CAT. NO: YAZV26TC38FXB	
CANADA:		DRAWN BY: PALANI M 11/26/2012	
1-800-361-6975 (QUEBEC)		CHECKER: --	
1-800-387-6487 (ALL OTHER PROVINCES)		DSN APRVL: --	
FOR PRODUCT INFO: http://www.burndy.com		MFG APRVL: --	
		QA APRVL: WATTS 07/26/2013	
		MKT APRVL: MICHAEL 07/31/2013	
		PROD FAM: CM&R COMPRESSION	
		DRAWING NO	
		50015428	
		REV	
		A	
		SHEET 1 OF 1	