

STRANDED COPPER CONDUCTOR ACCOMMODATED		BOLT SIZE	INSTALLATION TOOLING (# CRIMPS)					WIRE STRIP LENGTH	
			COLOR CODE	DIE INDEX	MECHANICAL	HYDRAULIC			DIELESS (# CRIMPS)
AWG	MM <sup>2</sup>					MD6, MD7-34R	BCT500HS, Y500CTHS	Y35, Y39, Y750, Y46, PAT750	
2/0 CLASS B, C 70mm <sup>2</sup> CLASS 2	70	1/2 [M12]	BLACK	13	W26VT (4) W26RT (4) X26RT (4)	W26VT (4) W26RT (4) X26RT (4)	U26RT (2)	MECHANICAL: MRC840 (4) MY29-3 (2) MY29-11 (2)  HYDRAULIC: Y644 (1) PAT644 (1) Y81KFT (2) PAT81KFT (2)	1-9/16"

REV	DATE	DESCRIPTION	ECO	BY	C'H'K.
A	11/27/2012	CREATE SALES DRAWING FOR CAT.# YA26T6	29531	MVP	DD

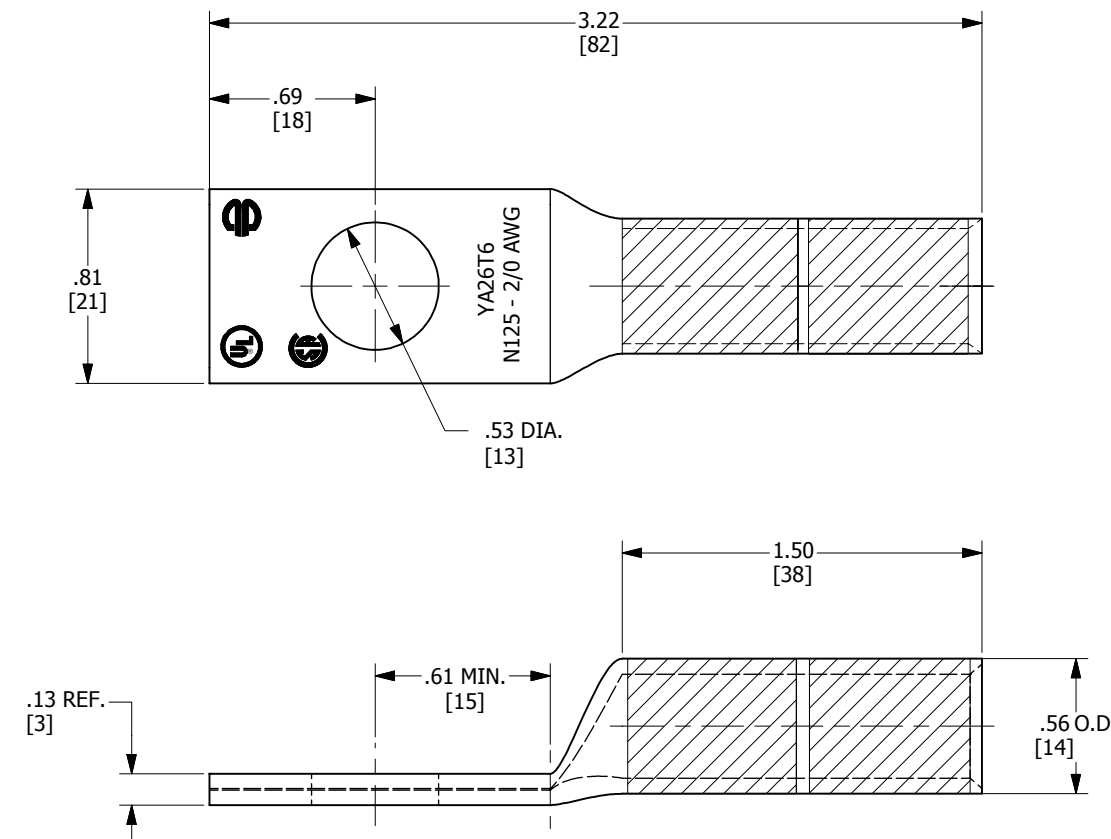

**NOTES:**

1. MATERIAL: COPPER TUBING.
2. FINISH: ELECTRO TIN PLATED.
3. CATALOG # PUADP-1 ADAPTOR IS REQUIRED TO USE "U" DIES IN Y46 SERIES TOOLS.
4. Y35P3 INDENTOR ADAPTOR REQUIRED FOR Y34PR INDENTOR.
5. DIMENSIONS IN BRACKETS [ ] ARE IN MILLIMETERS ROUNDED OFF TO THE NEAREST MILLIMETER, UNLESS OTHERWISE NOTED, AND ARE FOR REFERENCE ONLY.
6. UL LISTED AND CSA CERTIFIED WIRE CONNECTORS.

TO ORDER BURNDY® PRODUCTS CALL		HYLUG™	
UNITED STATES 1-800-346-4175 (LONDONDERRY, NH)		ITEM NO: 502382	
CANADA: 1-800-361-6975 (QUEBEC) 1-800-387-6487 (ALL OTHER PROVINCES)		CAT. NO: YA26T6	
FOR PRODUCT INFO: <a href="http://www.burndy.com">http://www.burndy.com</a>		DRAWN BY: MVP 11/27/2012	
		CHECKER: --	
		DSN APRVL: --	
		MFG APRVL: --	
		QA APRVL: WATTS 07/26/2013	
		MKT APRVL: MICHAEL 07/31/2013	
		PROD FAM: CM&R COMPRESSION	
		DRAWING NO	
		50015524	
		REV	
		A	
		SHEET 1 OF 1	