

| REV | DATE      | DESCRIPTION                 | ECO   | BY | CHK. |
|-----|-----------|-----------------------------|-------|----|------|
| B   | 6/12/2014 | MODIFIED AS A TABLE DRAWING | 36401 | DK | MA   |

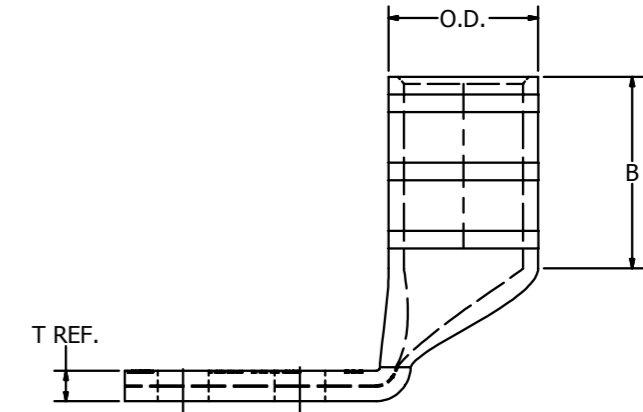
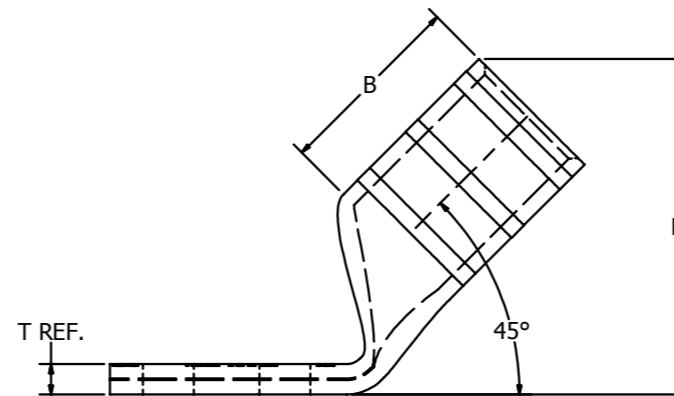
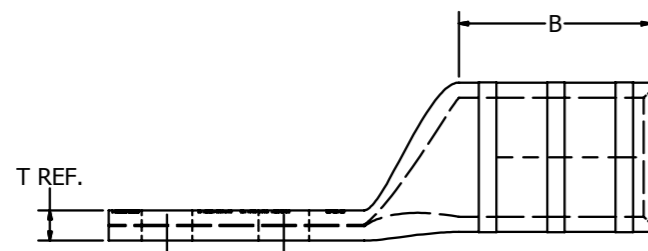
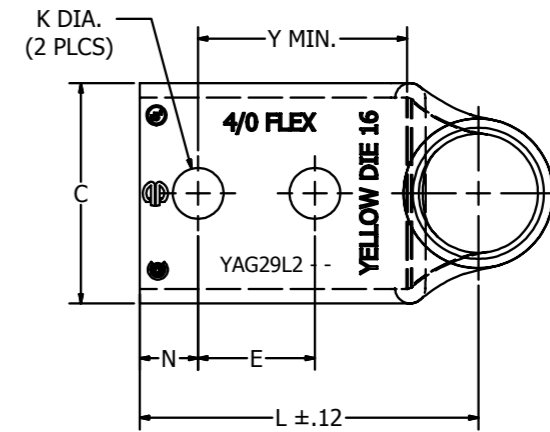
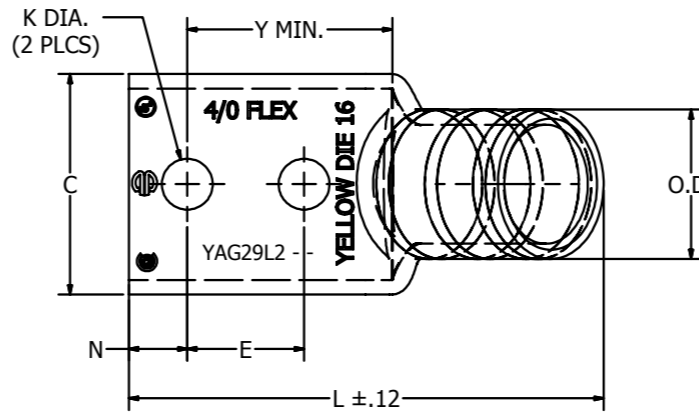
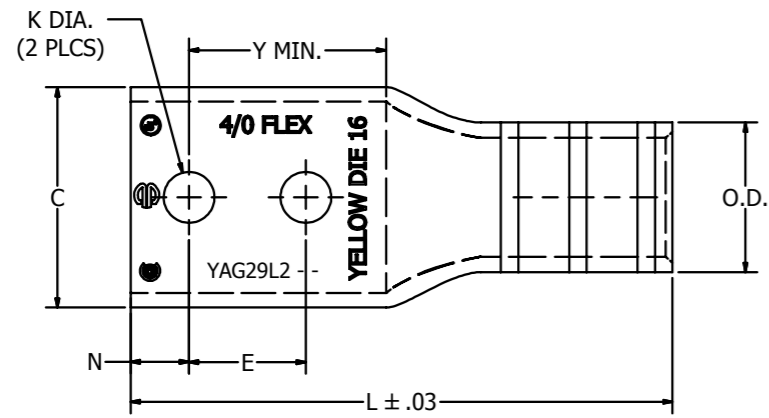

FIG. 1

FIG. 2

FIG. 3

NOTES:

- 1 MATERIAL: COPPER TUBING.
- 2 FINISH: LEAD PLATED.
- 3 CATALOG # PT6515 ADAPTOR IS REQUIRED TO USE "U" DIES IN Y45 SERIES TOOLS.
- 4 CATALOG # PUADP-1 ADAPTOR IS REQUIRED TO USE "U" DIES IN Y46 SERIES TOOLS.
- 5 Y35P3 INDENTOR ADAPTOR REQUIRED FOR Y34PR INDENTOR.
6. DIMENSIONS IN BRACKETS [ ] ARE IN MILLIMETERS ROUNDED OFF TO THE NEAREST MILLIMETER, UNLESS OTHERWISE NOTED, AND ARE FOR REFERENCE ONLY.
7. UL LISTED AND CSA CERTIFIED WIRE CONNECTORS.

|  |                            |            |
|--|----------------------------|------------|
| TO ORDER BURNDY® PRODUCTS CALL<br><br>UNITED STATES<br>1-800-346-4175 (LONDONDERRY, NH)<br><br>CANADA:<br>1-800-361-6975 (QUEBEC)<br>1-800-387-6487 (ALL OTHER PROVINCES)<br><br>FOR PRODUCT INFO: <a href="http://www.burndy.com">http://www.burndy.com</a> | HYLUG™                     |            |
|  | ITEM NO: SEE TABLE         |            |
|  | CAT. NO: SEE TABLE         |            |
|  | DRAWN BY: MVP              | 11/28/2012 |
|  | CHECKER: --                |            |
|  | DSN APRVL: --              |            |
|  | MFG APRVL: --              |            |
|  | QA APRVL: WATTS            | 7/26/2013  |
|  | MKT APRVL: MICHAEL         | 7/31/2013  |
|  | PROD FAM: CM&R COMPRESSION | DRAWING NO |
| PROJECT #: --  | SIZE                       |            |
| DOCUMENT TYPE: SALES   | 50015637                   |            |
| REL LEVEL: Released  | D                          |            |
|  | SHEET 1 OF 2               |            |
|  | REV                        |            |
|  | B                          |            |

