

| REV | DATE       | DESCRIPTION                     | ECO   | BY | C'H'K. |
|-----|------------|---------------------------------|-------|----|--------|
| A   | 04/18/2013 | SALES DRAWING FOR CAT# PENA5GAL | 31331 | PM | MB     |

**BURNDY**<sup>®</sup>

CAT. NO.: PENA5GAL QTY.: 5 GAL. FILL DATE : XX/XX/XXXX

**PENETROX™ A**  
ELECTRICAL JOINT COMPOUND

RECOMMENDED FOR USE ON ALUMINUM TO ALUMINUM AND ALUMINUM TO COPPER CONNECTORS, ON BARE CONDUCTORS, ON BUS BARS. ASSURES HIGH CONDUCTIVITY JOINT BY SEALING OUT AIR AND MOISTURE TO PREVENT CORROSION AND REFORMATION OF OXIDE FILM.

----- DIRECTIONS -----

1. ABRASE CONDUCTORS WITH WIRE BRUSH OR EMERY CLOTH.
2. ABRASE ALUMINUM CONNECTORS IF NOT PREFILLED WITH PENETROX™ A. DO NOT ABRASE PLATED CONNECTORS.
3. MIX CONTENTS PRIOR TO USE.
4. APPLY PENETROX™ A LIBERALLY TO BOTH CONNECTOR AND CONDUCTOR.
5. ASSEMBLE JOINT.
6. WIPE OFF EXCESS MATERIAL FROM INSULATION.

LISTED 824F

STORE AT TEMPERATURE BELOW 110DEG.F (43 DEG. C). USE ABOVE -25 DEG. C.  
PENETROX A™ ALSO LUBRICATES AND INSURES CONTINUITY OF GROUND ON ALUM. CONDUIT THREADS

CONDUCTOR TERMINATION COMPOUNDS. DCI 781810-59283 STK 547305

7664 1985 BURNDY CORPORATION □ MANCHESTER, NH 03109

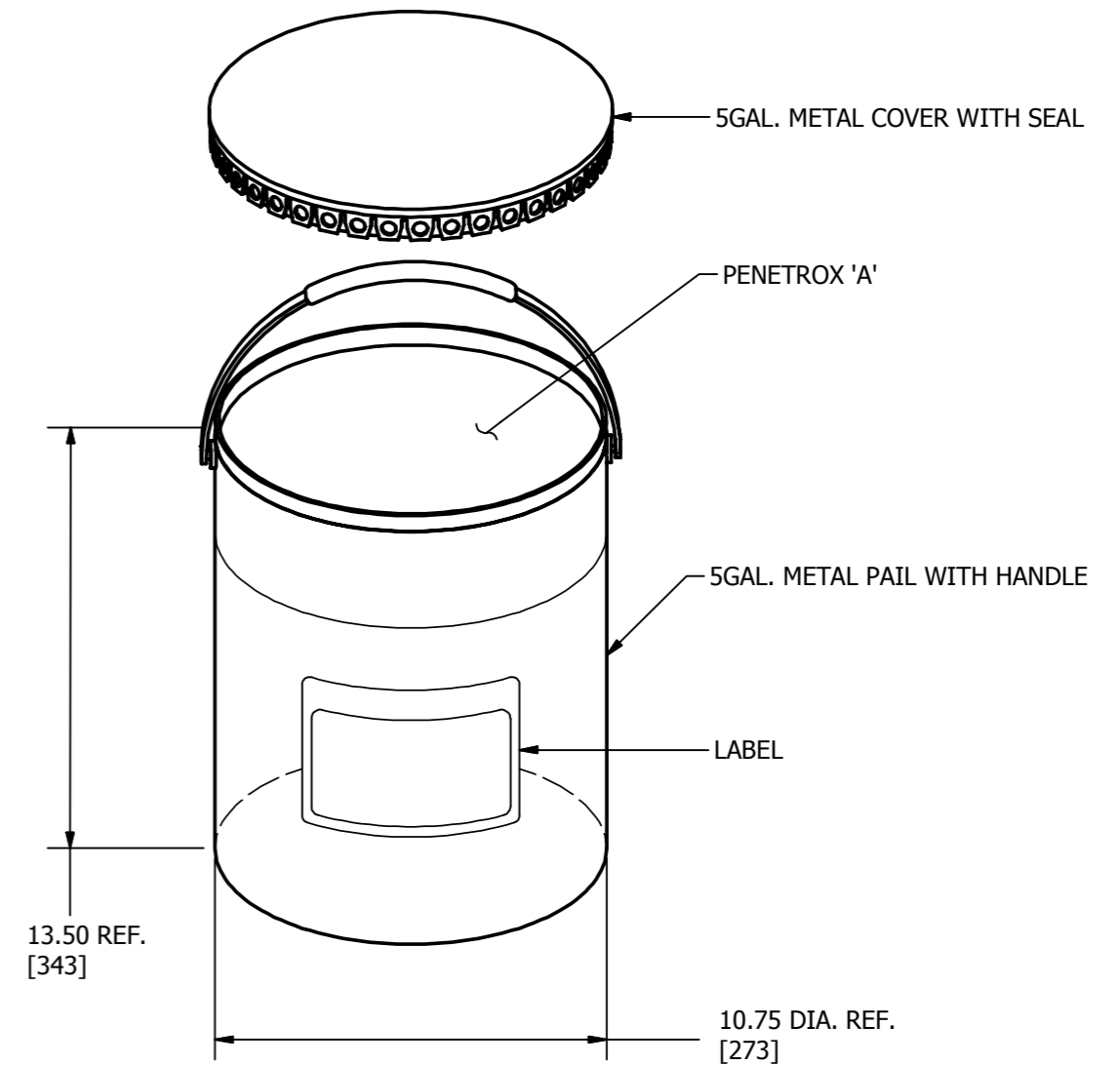

**NOTES:**

1. DIMENSIONS IN BRACKETS [ ] ARE IN MILLIMETERS ROUNDED OFF TO THE NEAREST MILLIMETER, UNLESS OTHERWISE SPECIFIED AND ARE FOR REFERENCE ONLY.
2. PAIL : 5 GALLON STEEL PAIL WITH HANDLE, 28/26 GAUGE - BLACK, WITH SEPERATE LUG COVER AND GASKET.
3. LABEL FULL SIZE : 5.00 [127] X 6.00 [152]

|   |  |                                   |  |
|---|--|-----------------------------------|--|
| TO ORDER BURNDY® PRODUCTS CALL<br>UNITED STATES<br>1-800-346-4175 (LONDONDERRY, NH) |  | PEN'A' 5GAL.TUB                   |  |
|   |  | ITEM NO: 547305                   |  |
| CANADA:<br>1-800-361-6975 (QUEBEC)<br>1-800-387-6487 (ALL OTHER PROVINCES)          |  | CAT. NO: PENA5GAL                 |  |
|   |  | DRAWN BY: PALANI M 12/06/2012     |  |
| FOR PRODUCT INFO: <a href="http://www.burndy.com">http://www.burndy.com</a>         |  | CHECKER: K BOUTIN 08/29/2013      |  |
|   |  | DSN APRVL: K BOUTIN 08/29/2013    |  |
|   |  | MFG APRVL: --                     |  |
|   |  | QA APRVL: C ACKERMAN 08/22/2013   |  |
|   |  | MKT APRVL: R CAVANAUGH 08/01/2013 |  |
|   |  | PROJ #: --                        |  |
|   |  | DRAWING NO                        |  |
|   |  | 50016091                          |  |
|   |  | REV                               |  |
|   |  | A                                 |  |
|   |  | SIZE                              |  |
|   |  | B                                 |  |
|   |  | DOCUMENT TYPE: SALES              |  |
|   |  | REL LEVEL: Released               |  |
|   |  | SHEET 1 OF 1                      |  |