

CATALOG NUMBER	CONDUCTOR O.D.	LINER MATERIAL
S2GBP451ASG4	1.08 - 1.15 [27.4 - 29.2]	EPDM
S2GBP451ASG1HT	1.08 - 1.15 [27.4 - 29.2]	SILICONE
S2GBP47ASG1	1.15 - 1.19 [29.2 - 30.2]	EPDM
S2GBP47ASG2HT	1.15 - 1.19 [29.2 - 30.2]	SILICONE
S2GBP48ASG2	1.19 - 1.25 [30.2 - 31.8]	EPDM
S2GBP48ASG1HT	1.19 - 1.25 [30.2 - 31.8]	SILICONE
S2GBP52ASG1	1.25 - 1.31 [31.8 - 33.3]	EPDM
S2GBP52ASG2HT	1.25 - 1.31 [31.8 - 33.3]	SILICONE
S2GBP51ASG1	1.32 - 1.36 [33.5 - 34.5]	EPDM
S2GBP51ASG2HT	1.32 - 1.36 [33.5 - 34.5]	SILICONE
S2GBP521ASG1	1.37-1.41 [34.8-35.8]	EPDM
S2GBP521ASG2HT	1.37-1.41 [34.8-35.8]	SILICON
S2GBP54ASG1	1.42-1.46 [36.1-37.1]	EPDM
S2GBP54ASG2HT	1.42-1.46 [36.1-37.1]	SILICON
S2GBP463ASG6	1.50 - 1.55 [38.1 - 39.4]	EPDM
S2GBP463ASG1HT	1.50 - 1.55 [38.1 - 39.4]	SILICONE

REV	DATE	DESCRIPTION	ECO	BY	C'HK.
H	03/18/2016	UPDATED AS PER MARKUP	36885	ARJ	MB

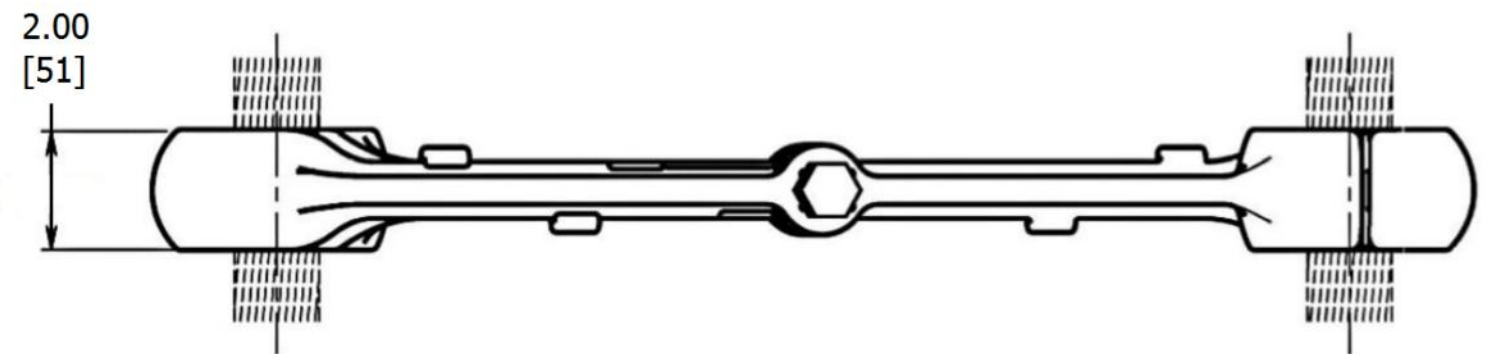
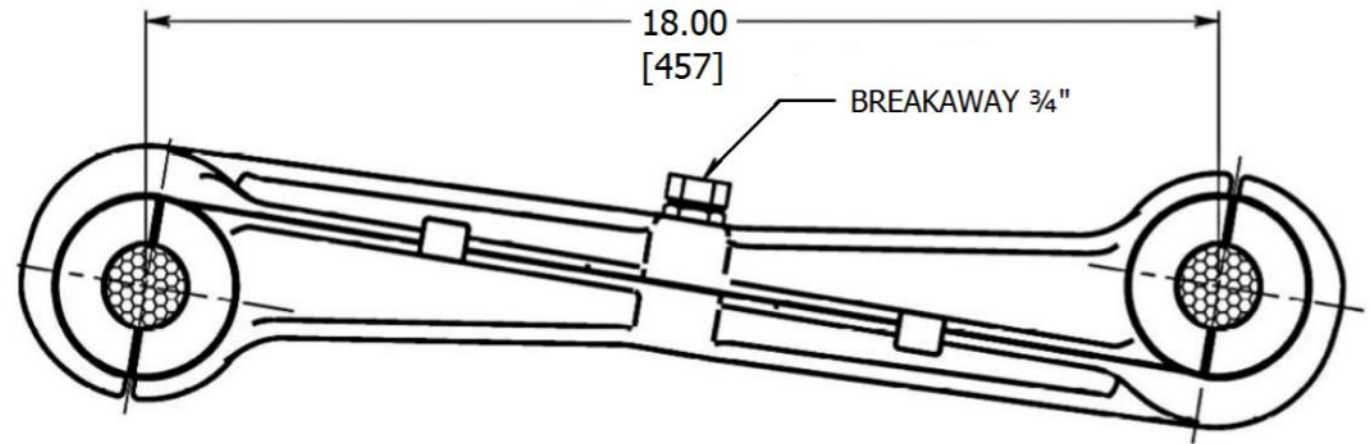

**NOTES:**

- MATERIAL :  
CONNECTOR : ALUMINUM ALLOY.  
SHEARHEAD BOLT : ALUMINUM ALLOY ASTM B210 BLACK ANODIZED.  
LINER : EPDM OR SILICONE (SEE TABLE).
- SILICONE RATED TO 250°C MAX.
- DIMENSIONS IN BRACKET [ ] DENOTE METRIC UNITS [SI UNIT].  
DIMENSIONS ARE FOR REFERENCE ONLY.
- DESIGNED FOR CORONA FREE OPERATION TO 500 KV.
- RECOMMENDED TIGHTENING TORQUE TO SHEAR OFF THE  
BREAKAWAY BOLT HEAD : 63 LB-FT [85 Nm]

TO ORDER BURNDY® PRODUCTS CALL		RIGID SPACER, 2 BUNDLE	
UNITED STATES 1-800-346-4175 (LONDONDERRY, NH)		ITEM NO: N/A	
CANADA: 1-800-361-6975 (QUEBEC) 1-800-387-6487 (ALL OTHER PROVINCES)		CAT. NO: SEE TABLE	
FOR PRODUCT INFO: <a href="http://www.burndy.com">http://www.burndy.com</a>		DRAWN BY: PALANI M 12/11/2012	
		CHECKER: CHAN P 12/11/2012	
		DSN APRVL: SCHRADER G 09/11/2013	
		MFG APRVL: --	
		QA APRVL: ACKERMAN C 09/11/2013	
		MKT APRVL: MOIST S 09/11/2013	
		PROD FAM: --	
		DRAWING NO	
		50016174	
		REV	
		H	
		SHEET 1 OF 1	