

LOADED REEL CATALOG NUMBER	TERMINAL TYPE	QUANTITY PER REEL	STUD SIZE	MACHINE NO.	CRIMP DIE INSERT NO. & LETTER CODE	TERMINAL CATALOG NUMBER	WIRE SIZE & TYPE	CABLE STRIP LENGTH
BA14EF6M	FORK	2000	4, 5 & 6	TFM1-2 TFM1D5	DFM2-1 BLUE	BA14EF6A	16 - 14 AWG, SOL & STR	1/4

REV	DATE	DESCRIPTION	ECO	BY	C'H'K.
A	12/11/2012	SALES DWG. FOR CAT# BA14EF6M	29537	PM	MB

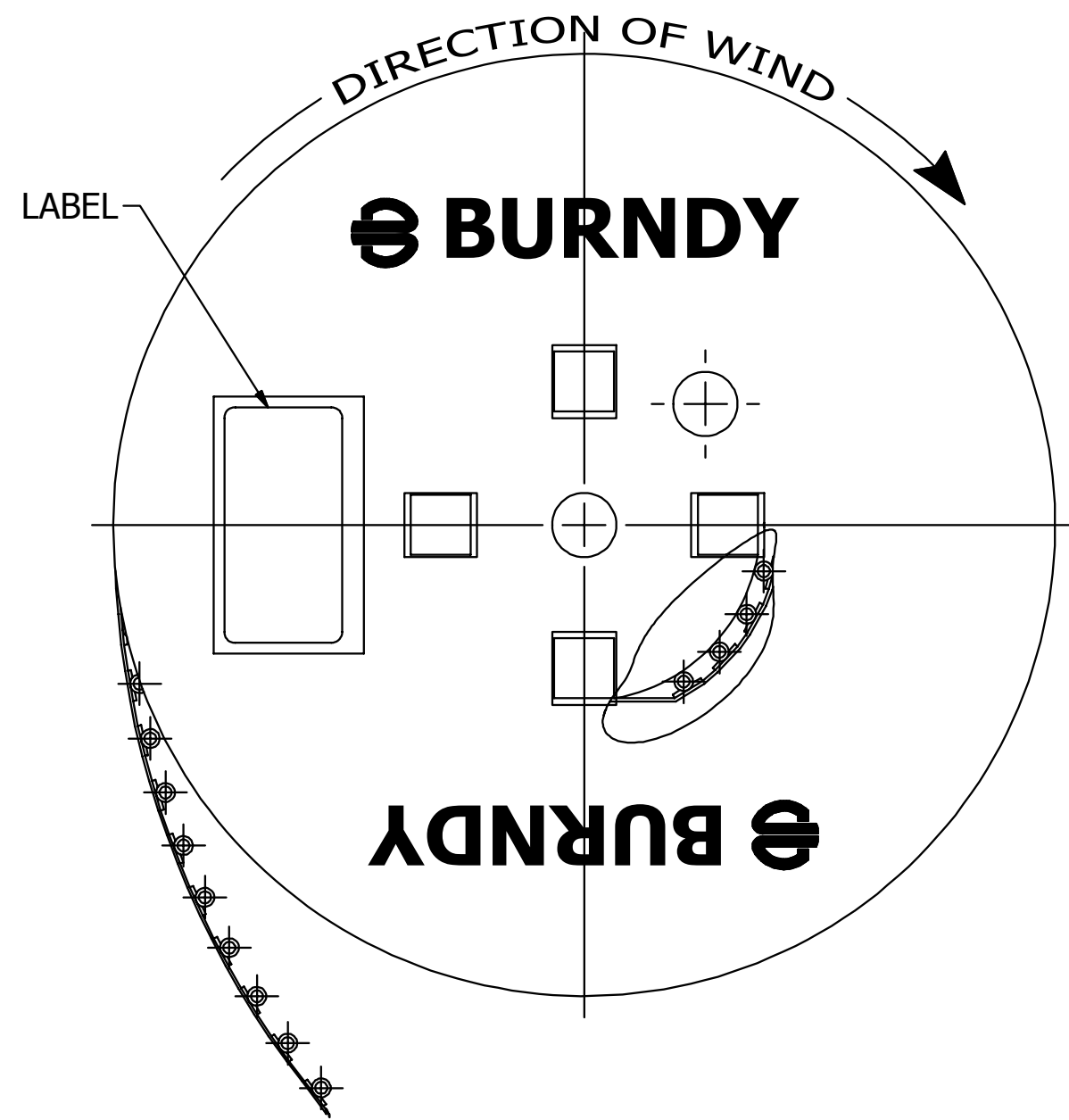

TYPICAL MYLAR STRIP WITH TERMINALS

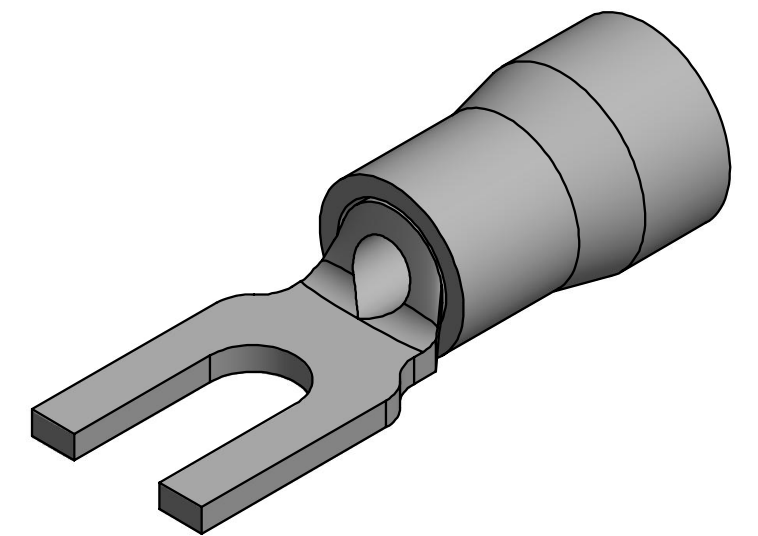
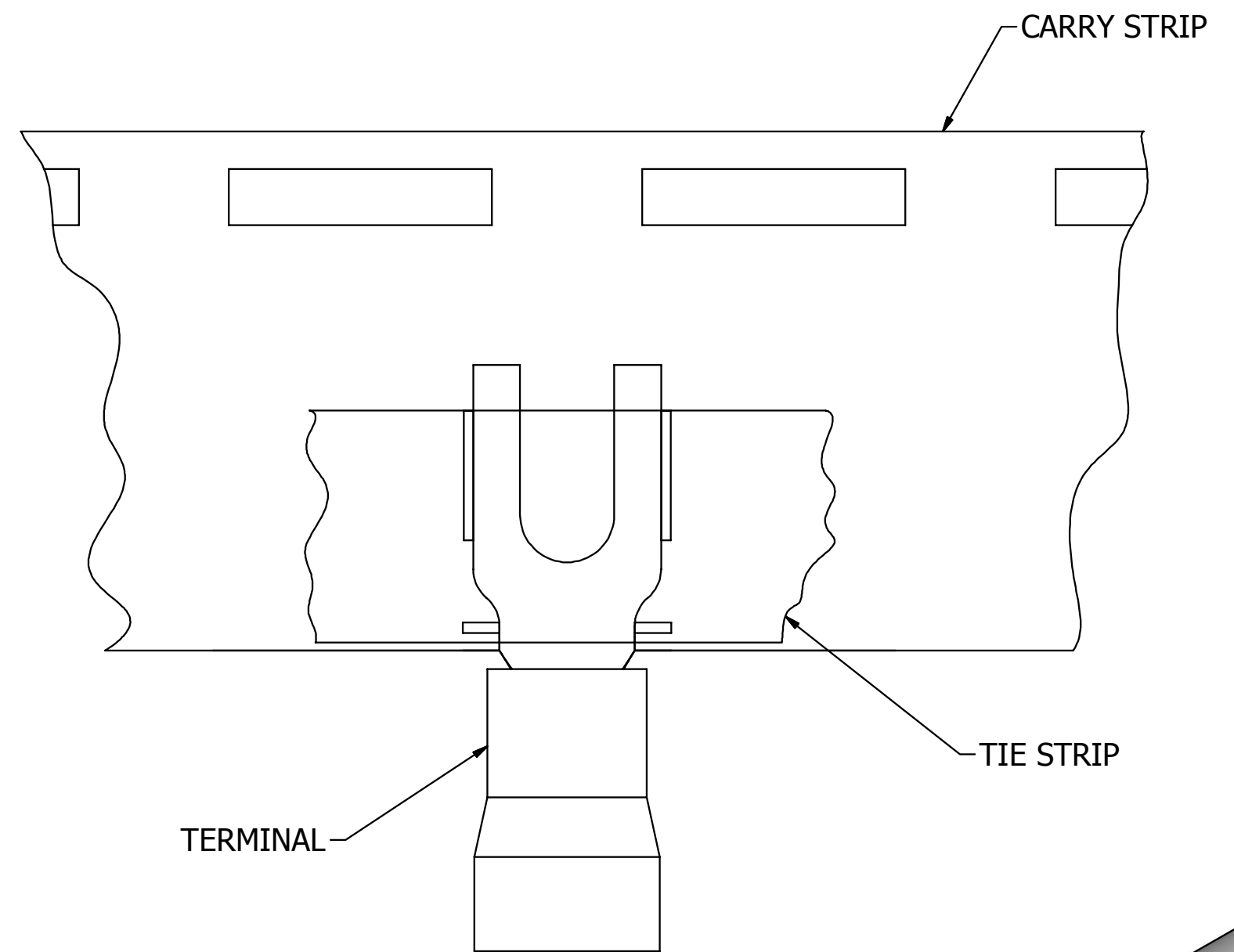

NOTES:

1. DIMENSIONS IN BRACKETS [] ARE IN MILLIMETERS ROUNDED OFF TO THE NEAREST MILLIMETER, UNLESS OTHERWISE SPECIFIED AND ARE FOR REFERENCE ONLY.

TO ORDER BURNDY® PRODUCTS CALL		REEL ASSEMBLY (FORK TYPE HYLUG)	
UNITED STATES 1-800-346-4175 (LONDONDERRY, NH)		ITEM NO: 696645	
CANADA: 1-800-361-6975 (QUEBEC) 1-800-387-6487 (ALL OTHER PROVINCES)		CAT. NO: BA14EF6M	
FOR PRODUCT INFO: http://www.burndy.com		DRAWN BY: PALANI M 12/11/2012	
		CHECKER: --	
		DSN APRVL: K CASTONGUAY 3/8/2017	
		MFG APRVL: --	
		QA APRVL: C LINQUIST 7/28/2016	
		MKT APRVL: M BAILLY 7/5/2016	
		PROD FAM: --	
		PROJECT #: --	
		DOCUMENT TYPE: SALES	
		REL LEVEL: Released	
		DRAWING NO	
		50016255	
		SHEET 1 OF 1	
		REV	
		A	