

LOADED REEL CATALOG NUMBER	TERMINAL TYPE	QUANTITY PER REEL	STUD SIZE	MACHINE NO.	CRIMP DIE INSERT NO. & LETTER CODE	TERMINAL CATALOG NUMBER	WIRE SIZE & TYPE	CABLE STRIP LENGTH
BA10EZ10M	FLANGED FORK	1000	8 & 10	TFM1-2 TFM1D5	DFM1-1 YELLOW	BA10EZ10A	12 - 10 AWG & STR	11/32

REV	DATE	DESCRIPTION	ECO	BY	C'H'K.
A	12/11/2012	SALES DWG. FOR CAT# BA10EZ10M	29537	PM	MB

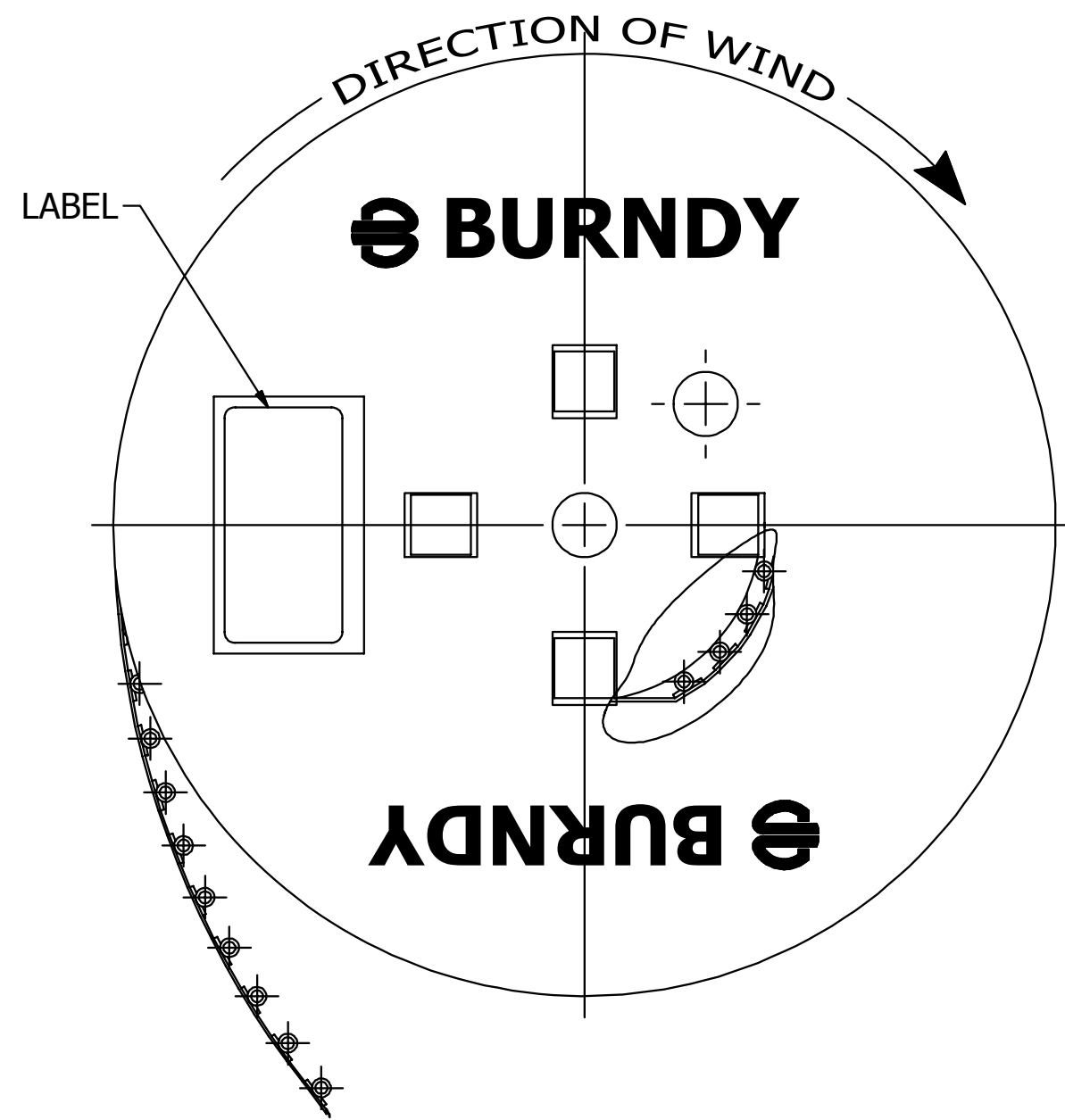

TYPICAL MYLAR STRIP WITH TERMINALS

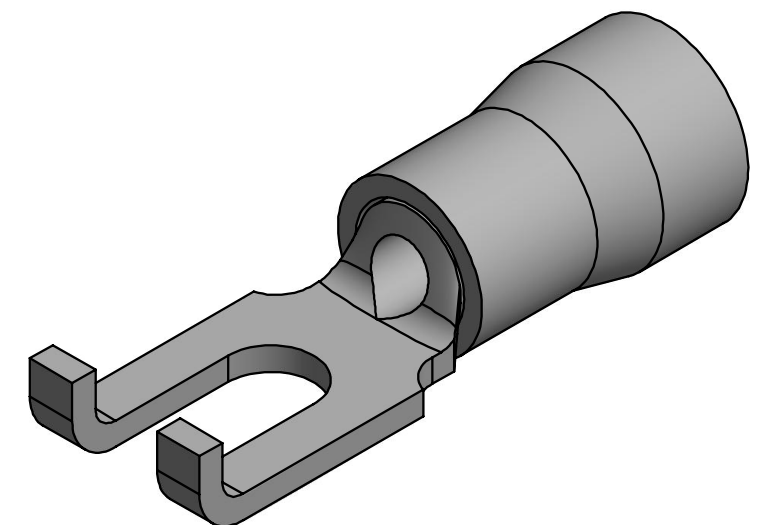
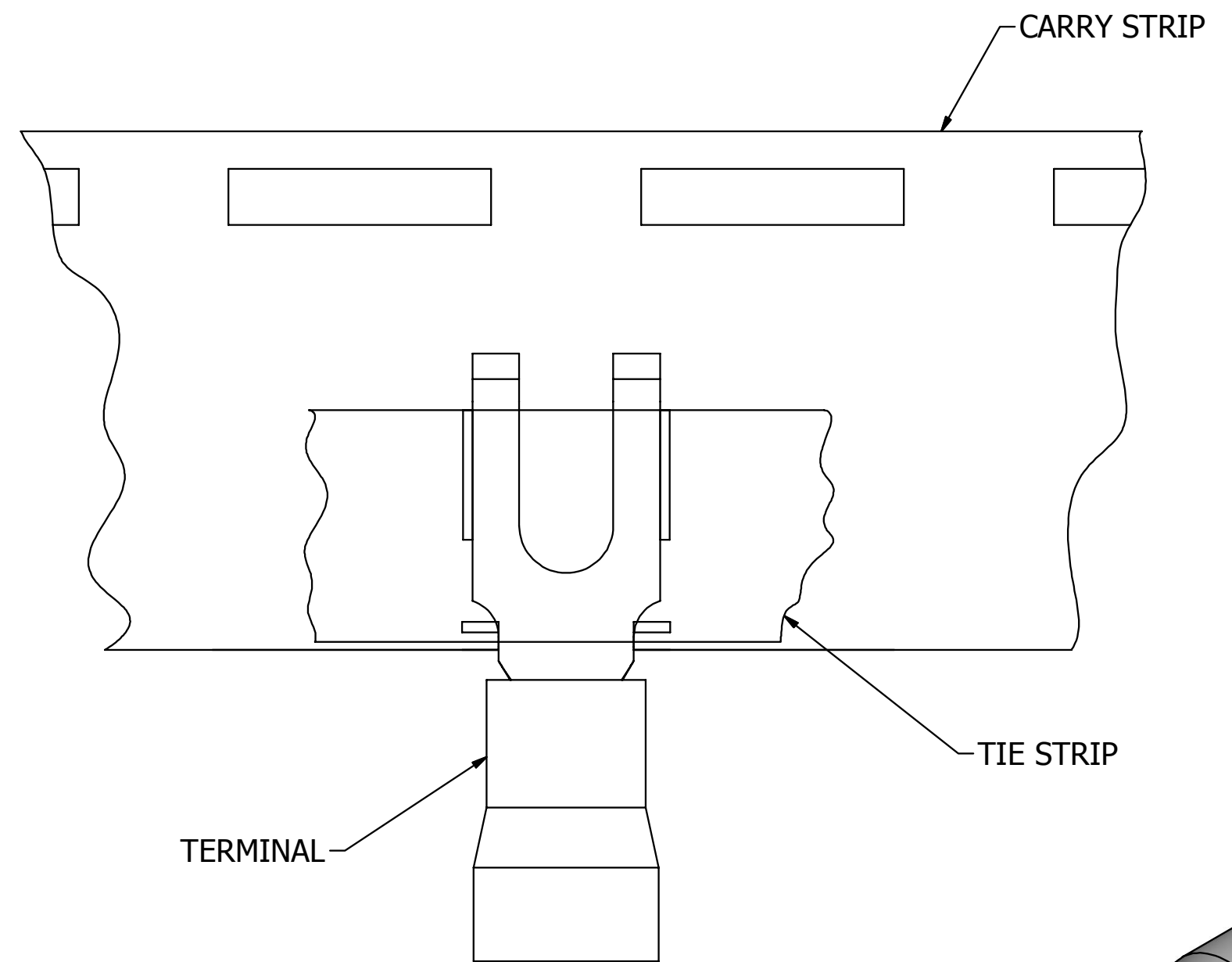

**NOTES:**

1. DIMENSIONS IN BRACKETS [ ] ARE IN MILLIMETERS ROUNDED OFF TO THE NEAREST MILLIMETER, UNLESS OTHERWISE SPECIFIED AND ARE FOR REFERENCE ONLY.

TO ORDER BURNDY® PRODUCTS CALL		REEL ASSEMBLY (FLANGED FORK TYPE HYLUG)	
UNITED STATES		ITEM NO: 696279	
1-800-346-4175 (LONDONDERRY, NH)		CAT. NO: BA10EZ10M	
CANADA:		DRAWN BY: PALANI M 12/11/2012	
1-800-361-6975 (QUEBEC)		CHECKER: --	
1-800-387-6487 (ALL OTHER PROVINCES)		DSN APRVL: K CASTONGUAY 3/8/2017	
FOR PRODUCT INFO: <a href="http://www.burndy.com">http://www.burndy.com</a>		MFG APRVL: --	
		QA APRVL: C LINQUIST 7/28/2016	
		MKT APRVL: M BAILLY 7/5/2016	
		PROD FAM: --	
		PROJECT #: --	
		DOCUMENT TYPE: SALES	
		REL LEVEL: Released	
		DRAWING NO	
		50016256	
		REV	
		A	
		SHEET 1 OF 1	