

REV	DATE	DESCRIPTION	ECO	BY	C'H'K.
A	12/11/2012	SALES DWG. FOR CAT# YAE22G14M & YAE22G15M	29537	PM	MB

LOADED REEL CATALOG NUMBER	TERMINAL TYPE	QUANTITY PER REEL	STUD SIZE	MACHINE NO.	CRIMP DIE INSERT NO. & LETTER CODE	TERMINAL CATALOG NUMBER	DIMENSIONS								
							K		C		N		D		L
							MAX.	MIN.	MAX.	MIN.	MAX.	MIN.	MAX.	MIN.	MAX.
YAE22G14M	RING	2000	--	--	--	YAE22G14	.176 [4]	.170 [4]	.325 [8]	.305 [8]	.162 [4]	.152 [4]	.315 [8]	.305 [7]	.816 [21]
YAE22G15M	RING	2000	--	--	--	YAE22G15	.201 [5]	.195 [5]	.325 [8]	.305 [8]	.162 [4]	.152 [4]	.315 [8]	.305 [7]	.816 [21]

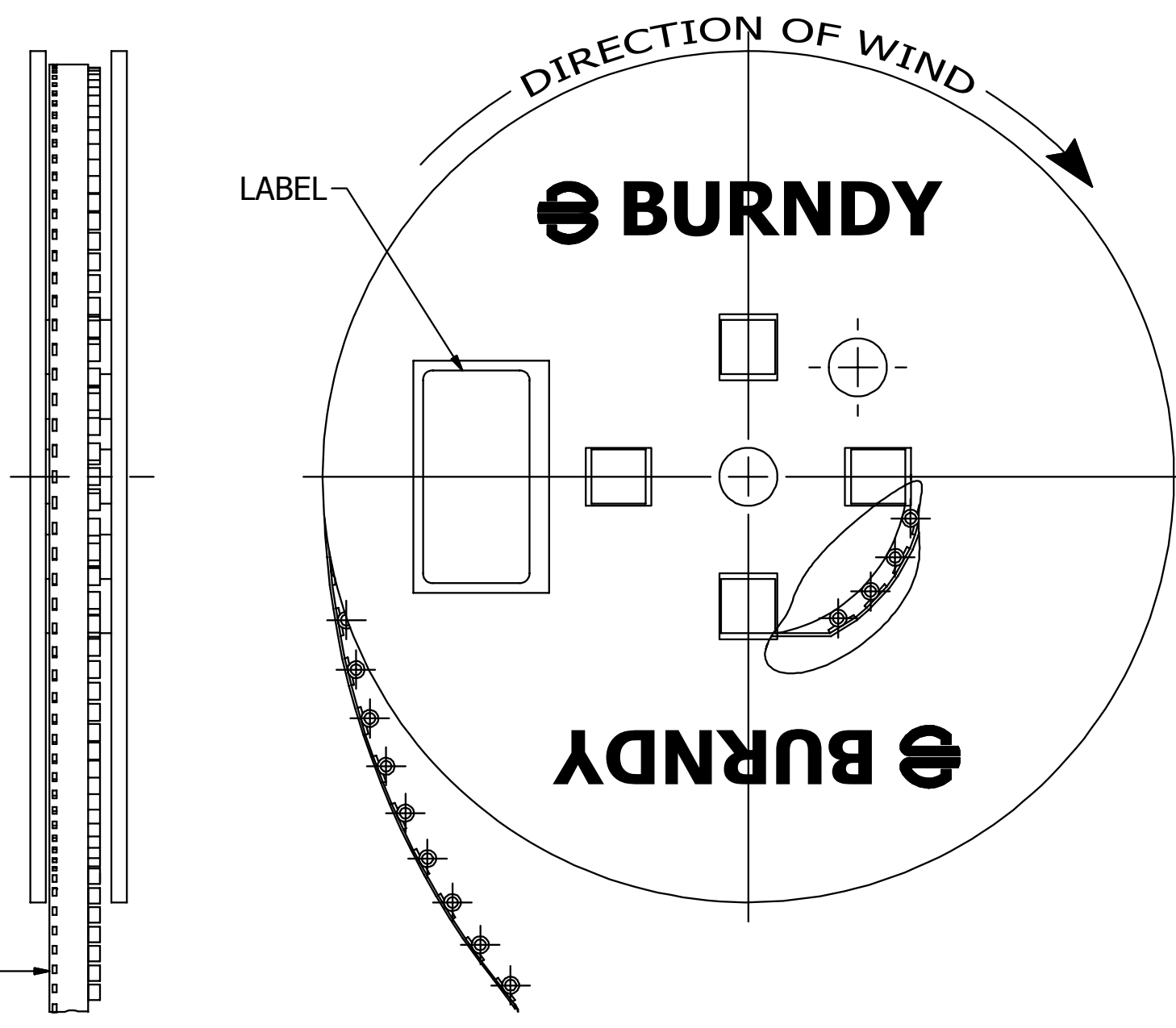

TYPICAL MYLAR STRIP WITH TERMINALS

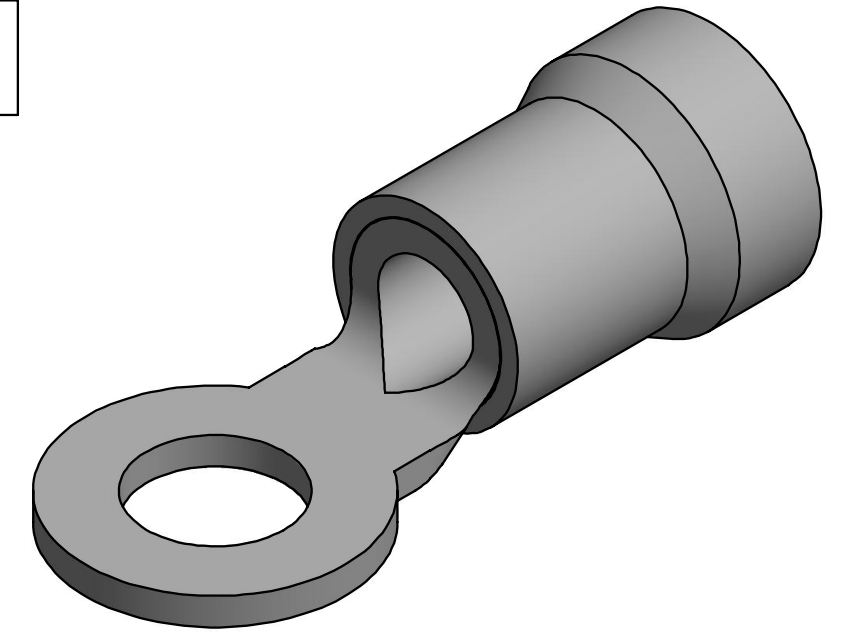
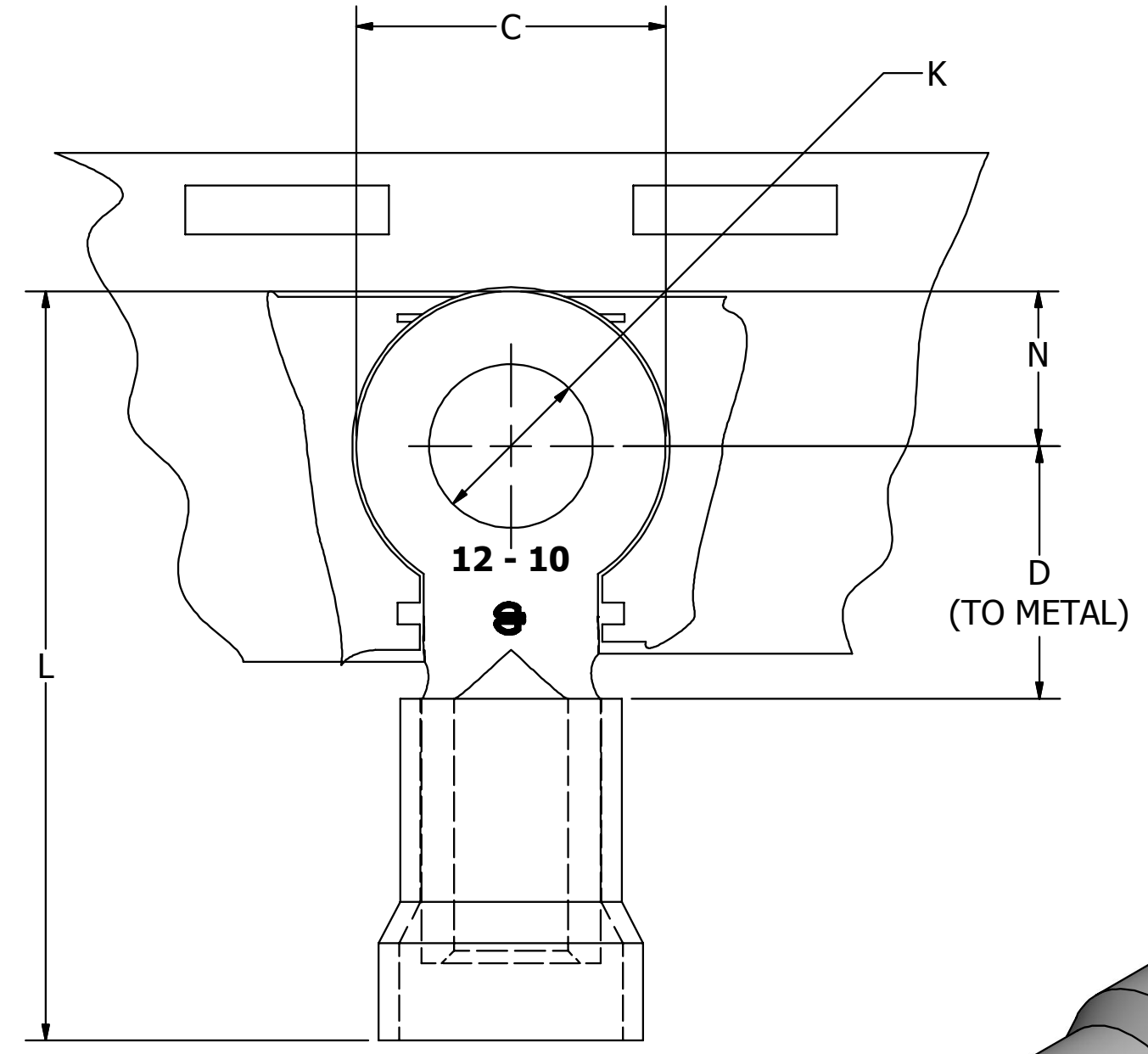

**NOTES:**

1. DIMENSIONS IN BRACKETS [ ] ARE IN MILLIMETERS ROUNDED OFF TO THE NEAREST MILLIMETER, UNLESS OTHERWISE SPECIFIED AND ARE FOR REFERENCE ONLY.
2. MATERIAL : COPPER
3. FINISH : TIN PLATED

TO ORDER BURNDY® PRODUCTS CALL		REEL ASSEMBLY (INSULUG)	
UNITED STATES 1-800-346-4175 (LONDONDERRY, NH)		ITEM NO: 643024 & 695018	
CANADA: 1-800-361-6975 (QUEBEC) 1-800-387-6487 (ALL OTHER PROVINCES)		CAT. NO: YAE22G14M & YAE22G15M	
FOR PRODUCT INFO: <a href="http://www.burndy.com">http://www.burndy.com</a>		DRAWN BY: PALANI M 12/11/2012	
		CHECKER: --	
		DSN APRVL: K CASTONGUAY 3/8/2017	
		MFG APRVL: --	
		QA APRVL: C LINQUIST 7/28/2016	
		MKT APRVL: M BAILLY 7/5/2016	
		PROD FAM: --	
		PROJECT #: --	
		DOCUMENT TYPE: SALES	
		REL LEVEL: Released	
		DRAWING NO	
		50016455	
		SHEET 1 OF 1	
		REV	
		A	