

REV	DATE	DESCRIPTION	ECO	BY	CHK.
A	02/28/2013	ACSS DOUBLE PAD,EHV FULL TENSION DEAD END KIT WITH TERMINAL HARDWARE SALES DOCUMENT UPDATED	30477	SRI	SP

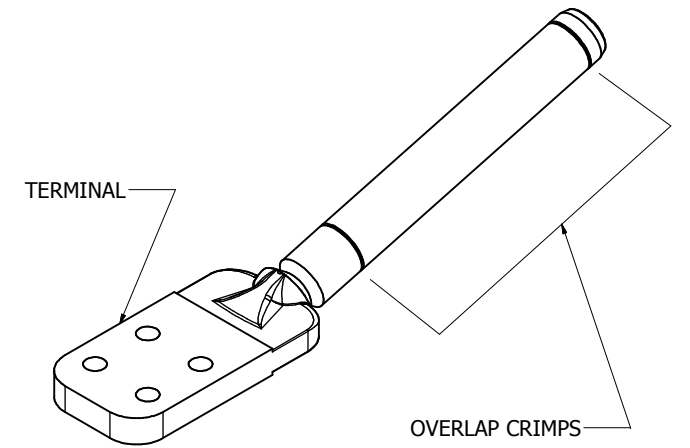
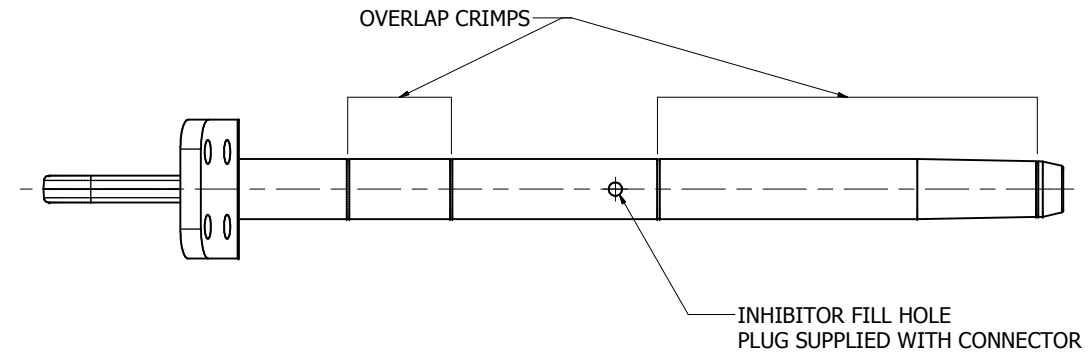
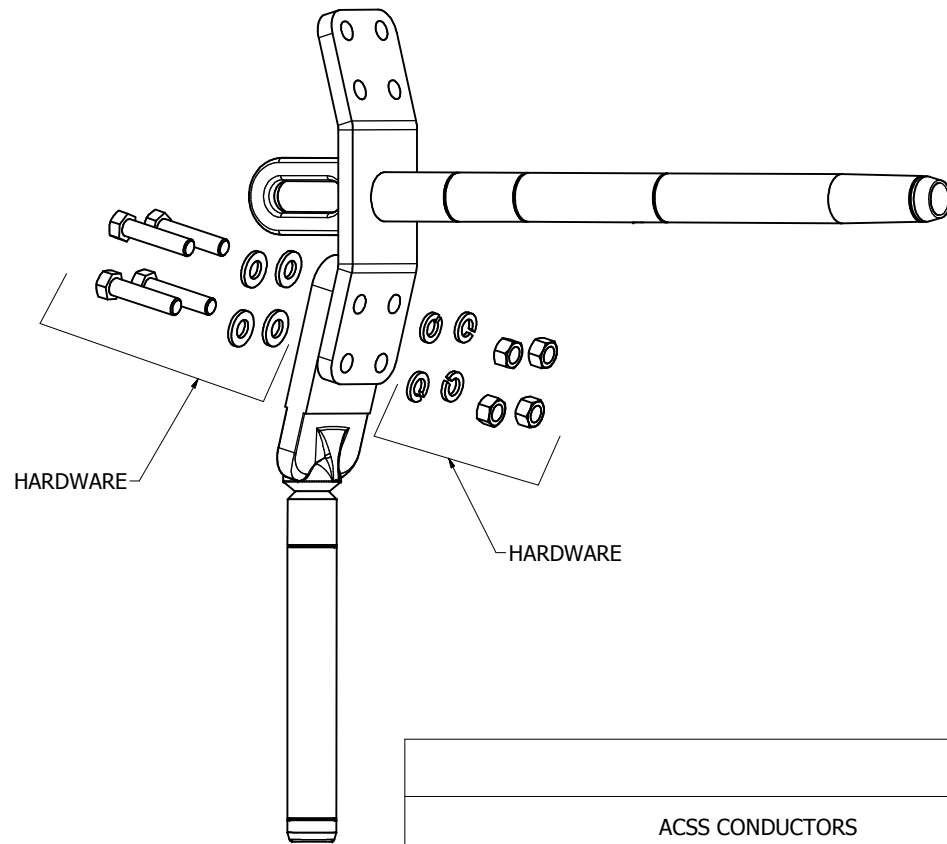

BURNDY FULL TENSION ACSS EHV DEAD END KITS,DOUBLE PAD,WITH TERMINAL

ACSS CONDUCTORS			DEAD END KITS		KITS CONTAINS (REFERENCE SALES DRAWINGS FOR INSTALLATION TOOLING, INSTALLATION TOOLING NOT INCLUDED)							
ACSS CONDUCTOR CODE NAME	Kcmil	STRANDING	CONDUCTOR O.D. INCHES[MM]	KIT CATALOG NUMBER	KIT ITEM NUMBER	ALUMINUM DEAD END ASSY.			TERMINAL			
						CATALOG NUMBER	COMPONENT SALES DRAWING	QTY	CATALOG NUMBER	MOUNTING HARDWARE CATALOG NUMBER	COMPONENT SALES DRAWING	QTY
LINNET	336.4	26/7	0.720 [18]	YTW32RDT34REKHT	30011119	YTW32RDT34REKHTNT	50020470	1	BYNA32RT15HHT	TMH9	10092588	2
ORIOLE	336.4	30/7	0.741 [19]	YTW32RDT33REKHT	30011117	YTW32RDT33REKHTNT		1	BYNA32RT15HHT	TMH9		2
IBIS	397.5	26/7	0.783 [20]	YTW34RDT34REKHT	30011137	YTW34RDT34REKHTNT		1	BYNA34RT15HHT	TMH9		2
FLICKER	477	24/7	0.846 [21]	YTW36RDT362REKHT	30011156	YTW36RDT362REKHTNT		1	BYNA36RT15HHT	TMH9		2
HAWK	477	26/7	0.858 [22]	YTW36RDT36REKHT	30011158	YTW36RDT36REKHTNT		1	BYNA36RT15HHT	TMH9		2
PARAKEET	556.5	24/7	0.914 [23]	YTW39RDT43REKHT	30011174	YTW39RDT43REKHTNT		1	BYNA39RT15HHT	TMH9		2
DOVE	556.5	26/7	0.927 [24]	YTW39RDT43REKHT	30011174	YTW39RDT43REKHTNT		1	BYNA39RT15HHT	TMH9		2
PEACOCK	605	24/7	0.953 [24]	YTW43RDT43REKHT	30011189	YTW43RDT43REKHTNT		1	BYNA43RT15HHT	TMH9		2

NOTES:

- MATERIAL:
 - CONNECTOR EYE : STEEL ALLOY
 - CONNECTOR TUBE ASSEMBLY, TERMINAL, ALUMINUM ALLOY, NO-OX-ID COATED
 - HARDWARE: BOLTS,FLAT WASHERS AND NUTS, ALUMINUM ALLOY
 - RESILIENT WASHERS, GALVANIZED STEEL
 - RUBBER GASKET
- RECOMMENDED TIGHTENING TORQUE:
ALUMINUM HARDWARE: 1/2-13 300 INCH POUNDS
- DESIGNED FOR CORONA FREE OPERATION UP TO 230KV WITHOUT ACCESSORIES
- DIMENSIONS IN BRACKETS [] ARE METRIC UNITS [SI UNITS] AND ARE ROUNDED TO THE NEAREST WHOLE NUMBER. UNLESS OTHERWISE SPECIFIED THESE UNITS SHALL BE USED FOR REFERENCE ONLY.

TO ORDER BURNDY® PRODUCTS CALL		FULL TENSION ACSS EHV DEADEND KITS WITH TERMINAL	
UNITED STATES		ITEM NO: SEE TABLE	
1-800-346-4175 (LONDONDERRY, NH)		CAT. NO: SEE TABLE	
CANADA:		DRAWN BY: A SRINIVASAN 2/28/2013	
1-800-361-6975 (QUEBEC)		CHECKER: S PANDIAN 2/28/2013	
1-800-387-6487 (ALL OTHER PROVINCES)		DSN APRVL: P WALTZ 3/22/2013	
FOR PRODUCT INFO: http://www.burndy.com		MFG APRVL: --	
		QA APRVL: C ACKERMAN 4/2/2013	
		MKT APRVL: D HAMILTON 3/25/2013	
		PROD FAM: TRANSMISSION	
		PROJECT #: --	
		SIZE	
		DOCUMENT TYPE: SALES	
		REL LEVEL: Released	
		DRAWING NO	
		50020585	
		SHEET 1 OF 2	
		REV	
		A	

BURNDY FULL TENSION ACSS EHV DEAD END KITS,DOUBLE PAD,WITH TERMINAL

ACSS CONDUCTORS				DEAD END KITS		KITS CONTAINS (REFERENCE SALES DRAWINGS FOR INSTALLATION TOOLING, INSTALLATION TOOLING NOT INCLUDED)						
ACSS CONDUCTOR CODE NAME	Kcmil	STRANDING	CONDUCTOR O.D. INCHES[MM]	KIT CATALOG NUMBER	KIT ITEM NUMBER	ALUMINUM DEAD END ASSY.			TERMINAL			
						CATALOG NUMBER	COMPONENT SALES DRAWING	QTY	CATALOG NUMBER	MOUNTING HARDWARE CATALOG NUMBER	COMPONENT SALES DRAWING	QTY
SQUAB	605	26/7	0.966 [25]	YTW43RDT43REKHT	30011189	YTW43RDT43REKHTNT	50020470	1	BYNA43RT15HHT	TMH4	10092588	2
ROOK	636	24/7	0.977 [25]	YTW43RDT43REKHT	30011189	YTW43RDT43REKHTNT	50020470	1	BYNA43RT15HHT	TMH4	10092588	2
GROSBKAK	636	26/7	0.991 [25]	YTW43RDT43REKHT	30011189	YTW43RDT43REKHTNT	50020470	1	BYNA43RT15HHT	TMH4	10092588	2
FLAMINGO	666.6	24/7	1.000 [25]	YTW43RDT43REKHT	30011189	YTW43RDT43REKHTNT	50020470	1	BYNA43RT15HHT	TMH4	10092588	2
STARLING	715.5	26/7	1.051 [27]	YTW451RDT48REKHT	10103094	YTW451RDT48REKHTNT	50020470	1	BYNA451RT15HHT	TMH24	10092588	2
CUCKOO	795	24/7	1.092 [28]	YTW451RDT45REKHT	30011211	YTW451RDT45REKHTNT	50020470	1	BYNA451RT15HHT	TMH24	10092588	2
DRAKE	795	26/7	1.107 [28]	YTW451RDT48REKHT	10103094	YTW451RDT48REKHTNT	50020470	1	BYNA451RT15HHT	TMH24	10092588	2
TERN	795	45/7	1.063 [27]	YTW451RDT481REKHT	30011213	YTW451RDT481REKHTNT	50020470	1	BYNA451RT15HHT	TMH24	10092588	2
CONDOR	795	54/7	1.092 [28]	YTW451RDT45REKHT	30011211	YTW451RDT45REKHTNT	50020470	1	BYNA451RT15HHT	TMH24	10092588	2
RUDDY	900	45/7	1.131 [29]	YTW48RDT481REKHT	30011250	YTW48RDT481REKHTNT	50020470	1	BYNA49RT15HHT	TMH24	10092588	2
RAIL	954	45/7	1.165 [30]	YTW48RDT481REKHT	30011250	YTW48RDT481REKHTNT	50020470	1	BYNA49RT15HHT	TMH24	10092588	2
CARDINAL	954	54/7	1.196 [30]	YTW48RDT48REKHT	30011252	YTW48RDT48REKHTNT	50020470	1	BYNA49RT15HHT	TMH24	10092588	2
ORTOLAN	1033.5	45/7	1.212 [31]	YTW49RDT483REKHT	30011263	YTW49RDT483REKHTNT	50020470	1	BYNA49RT15HHT	TMH24	10092588	2
CURLEW	1033.5	54/7	1.245 [31]	YTW49RDT50REKHT	30011265	YTW49RDT50REKHTNT	50020470	1	BYNA49RT15HHT	TMH24	10092588	2
BLUEJAY	1113	45/7	1.258 [32]	YTW49RDT483REKHT	30011263	YTW49RDT483REKHTNT	50020470	1	BYNA49RT15HHT	TMH24	10092588	2
FINCH	1113	54/19	1.292 [33]	YTW52RDT50REKHT	30011280	YTW52RDT50REKHTNT	50020470	1	BYNA52RT15HHT	TMH9	10092588	2
BUNTING	1192.5	45/7	1.302 [33]	YTW52RDT521REKHT	30011282	YTW52RDT521REKHTNT	50020470	1	BYNA52RT15HHT	TMH9	10092588	2
BITTERN	1272	45/7	1.345 [34]	YTW52RDT521REKHT	30011282	YTW52RDT521REKHTNT	50020470	1	BYNA52RT15HHT	TMH9	10092588	2
PHEASANT	1272	54/19	1.381 [35]	YTW52RDT56REKHT	30011284	YTW52RDT56REKHTNT	50020470	1	BYNA52RT15HHT	TMH9	10092588	2
DIPPER	1351.5	45/7	1.386 [35]	YTW52RDT521REKHT	30011282	YTW52RDT521REKHTNT	50020470	1	BYNA52RT15HHT	TMH9	10092588	2
MARTIN	1351.5	54/19	1.424 [36]	YTW52RDT56REKHT	30011284	YTW52RDT56REKHTNT	50020470	1	BYNA52RT15HHT	TMH9	10092588	2
NUTHATCH	1510.5	45/7	1.465 [37]	YTW549RDT521REKHT	30011300	YTW549RDT521REKHTNT	50020470	1	BYNA56RT15HHT	TMH9	10092588	2
PARROT	1510.5	54/19	1.505 [38]	YTW549RDT56REKHT	30011303	YTW549RDT56REKHTNT	50020470	1	BYNA56RT15HHT	TMH9	10092588	2
LAPWING	1590	45/7	1.504 [38]	YTW549RDT549REKHT	30011301	YTW549RDT549REKHTNT	50020470	1	BYNA56RT15HHT	TMH9	10092588	2
FALCON	1590	54/19	1.544 [39]	YTW56RDT590REKHT	30008805	YTW56RDT590REKHTNT	50020470	1	BYNA56RT15HHT	TMH9	10092588	2
CHUKAR	1780	84/19	1.601 [41]	YTW58RDT58REKHT	30011327	YTW58RDT58REKHTNT	50020470	1	BYNA58RT15HHT	TMH9	10092588	2
BLUEBIRD	2156	84/19	1.762 [45]	YTW59RDT59REKHT	30011346	YTW59RDT59REKHTNT	50020470	1	BYNA59RT15HHT	TMH9	10092588	2
KIWI	2167	72/7	1.735 [44]	YTW59RDT591REKHT	30011344	YTW59RDT591REKHTNT	50020470	1	BYNA59RT15HHT	TMH9	10092588	2

<p align="center">TO ORDER BURNDY® PRODUCTS CALL</p> <p align="center">UNITED STATES 1-800-346-4175 (LONDONDERRY, NH)</p> <p align="center">CANADA: 1-800-361-6975 (QUEBEC) 1-800-387-6487 (ALL OTHER PROVINCES)</p> <p>FOR PRODUCT INFO: http://www.burndy.com</p>		<p align="center">FULL TENSION ACSS EHV DEADEND KITS WITH TERMINAL</p> <p>ITEM NO: SEE TABLE</p> <p>CAT. NO: SEE TABLE</p> <p>DRAWN BY: A SRINIVASAN 2/28/2013</p> <p>CHECKER: S PANDIAN 2/28/2013</p> <p>DSN APRVL: P WALTZ 3/22/2013</p> <p>MFG APRVL: --</p> <p>QA APRVL: C ACKERMAN 4/2/2013</p> <p>MKT APRVL: D HAMILTON 3/25/2013</p>		
<p>PROJECT #: --</p> <p>DOCUMENT TYPE: SALES</p> <p>REL LEVEL: Released</p>	<p>SIZE: D</p>	<p>DRAWING NO: 50020585</p> <p>SHEET 2 OF 2</p>	<p>REV: A</p>	