

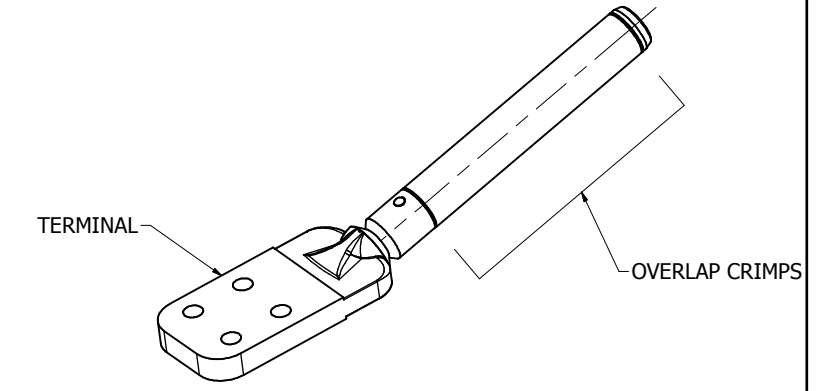

REV	DATE	DESCRIPTION	ECO	BY	C'H'K.
A	02/11/2013	CREATE SALES DOCUMENT FOR ACSS_NON EHV_DOUBLE_PAD_DEADEND (CAT.# YTW-RD-REKHT)	30478	SP	PW

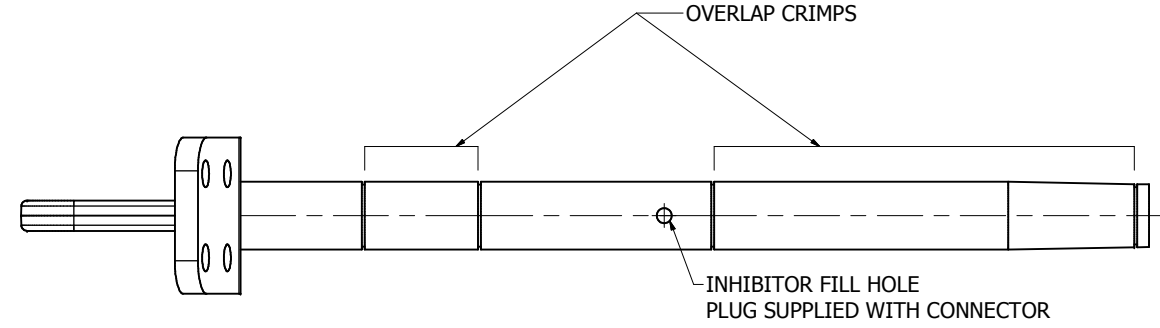
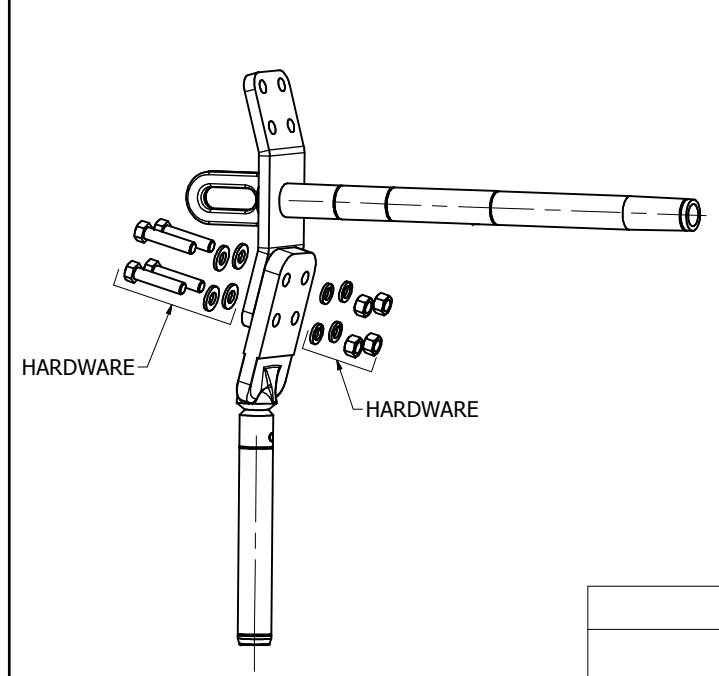

BURNDY FULL TENSION ACSS NON EHV DEAD END KITS,DOUBLE PAD												
ACSS CONDUCTORS				DEAD END KITS		KITS CONTAINS (REFERENCE SALES DRAWINGS FOR INSTALLATION TOOLING, INSTALLATION TOOLING NOT INCLUDED)						
ACSS CONDUCTOR CODE NAME	Kcmil	STRANDING	CONDUCTOR O.D. INCHES[MM]	KIT CATALOG NUMBER	KIT ITEM NUMBER	ALUMINUM DEAD END ASSY.			TERMINAL			
						CATALOG NUMBER	COMPONENT SALES DRAWING	QTY	CATALOG NUMBER	MOUNTING HARDWARE CATALOG NUMBER	COMPONENT SALES DRAWING	QTY
LINNET	336.4	26/7	0.720 [18]	YTW32RD34REKHT	30011114	YTW32RD34REKHTNT	50020685	1	BYNA32R15HHT	TMH9	10113639	2
ORIOLE	336.4	30/7	0.741 [19]	YTW32RD33REKHT	30011112	YTW32RD33REKHTNT		1	BYNA32R15HHT	TMH9		2
IBIS	397.5	26/7	0.783 [20]	YTW34RD34REKHT	30011134	YTW34RD34REKHTNT		1	BYNA34R15HHT	TMH9		2
FLICKER	477	24/7	0.846 [21]	YTW36RD362REKHT	30011152	YTW36RD362REKHTNT		1	BYNA36R15HHT	TMH9		2
HAWK	477	26/7	0.858 [22]	YTW36RD36REKHT	30011153	YTW36RD36REKHTNT		1	BYNA36R15HHT	TMH9		2
PARAKEET	556.5	24/7	0.914 [23]	YTW39RD43REKHT	30011171	YTW39RD43REKHTNT		1	BYNA39R15HHT	TMH9		2
DOVE	556.5	26/7	0.927 [24]	YTW39RD43REKHT	30011171	YTW39RD43REKHTNT		1	BYNA39R15HHT	TMH9		2
PEACOCK	605	24/7	0.953 [24]	YTW43RD43REKHT	30011186	YTW43RD43REKHTNT		1	BYNA43R15HHT	TMH4		2
SQUAB	605	26/7	0.966 [25]	YTW43RD43REKHT	30011186	YTW43RD43REKHTNT		1	BYNA43R15HHT	TMH4		2
ROOK	636	24/7	0.977 [25]	YTW43RD43REKHT	30011186	YTW43RD43REKHTNT		1	BYNA43R15HHT	TMH4		2
GROSBEAK	636	26/7	0.991 [25]	YTW43RD43REKHT	30011186	YTW43RD43REKHTNT		1	BYNA43R15HHT	TMH4		2
FLAMINGO	666.6	24/7	1.000 [25]	YTW43RD43REKHT	30011186	YTW43RD43REKHTNT		1	BYNA43R15HHT	TMH4		2

NOTES:

- MATERIAL
 - CONNECTOR EYE, STEEL ALLOY
 - CONNECTOR TUBE ASSEMBLY AND TERMINAL ALUMINUM ALLOY, NO-OX-ID COATED
 - HARDWARE: BOLTS, FLAT WASHERS AND NUTS, ALUMINUM ALLOY
 - RESILIENT WASHERS, GALVANIZED STEEL
 - RUBBER GASKET
- RECOMMENDED TIGHTENING TORQUE:
ALUMINUM HARDWARE: 1/2-13 300 INCH POUNDS.
- DESIGNED FOR CORONA FREE OPERATION UP TO 230KV WITHOUT ACCESSORIES.
- DIMENSIONS IN BRACKETS [] DENOTES METRIC UNITS [SI UNITS] AND ARE ROUNDED TO THE NEAREST WHOLE NUMBER. UNLESS OTHERWISE SPECIFIED THESE UNITS SHALL BE USED FOR REFERENCE ONLY.

TO ORDER BURNDY® PRODUCTS CALL		DOUBLE PAD NON EHV FULL TENSION DEADEND-ACSS	
UNITED STATES 1-800-346-4175 (LONDONDERRY, NH)		ITEM NO: SEE TABLE CAT. NO: SEE TABLE	
CANADA: 1-800-361-6975 (QUEBEC) 1-800-387-6487 (ALL OTHER PROVINCES)		DRAWN BY: S PANDIAN 3/5/2013 CHECKER: M MOHAN 3/6/2013 DSN APRVL: P WALTZ 3/25/2013 MFG APRVL: -- QA APRVL: C ACKERMAN 4/2/2013 MKT APRVL: D HAMILTON 3/25/2013	
FOR PRODUCT INFO: http://www.burndy.com			
PROJECT #:	SIZE	DRAWING NO	REV
DOCUMENT TYPE: SALES	D	50020686	A
REL LEVEL: Released		SHEET 1 OF 1	