

ACCESSORIES (SOLD SEPARATELY)	
DESCRIPTION	CATALOG NO.
U-DIE HOLDER SET	PT50024685
W-DIE HOLDER SET	PT50024683

REV.	DATE	DESCRIPTION	ECO	BY	C'H'K.
B	01/02/2014 00:00:00 AM	DRAWING RELEASED	34307	TRF	BV

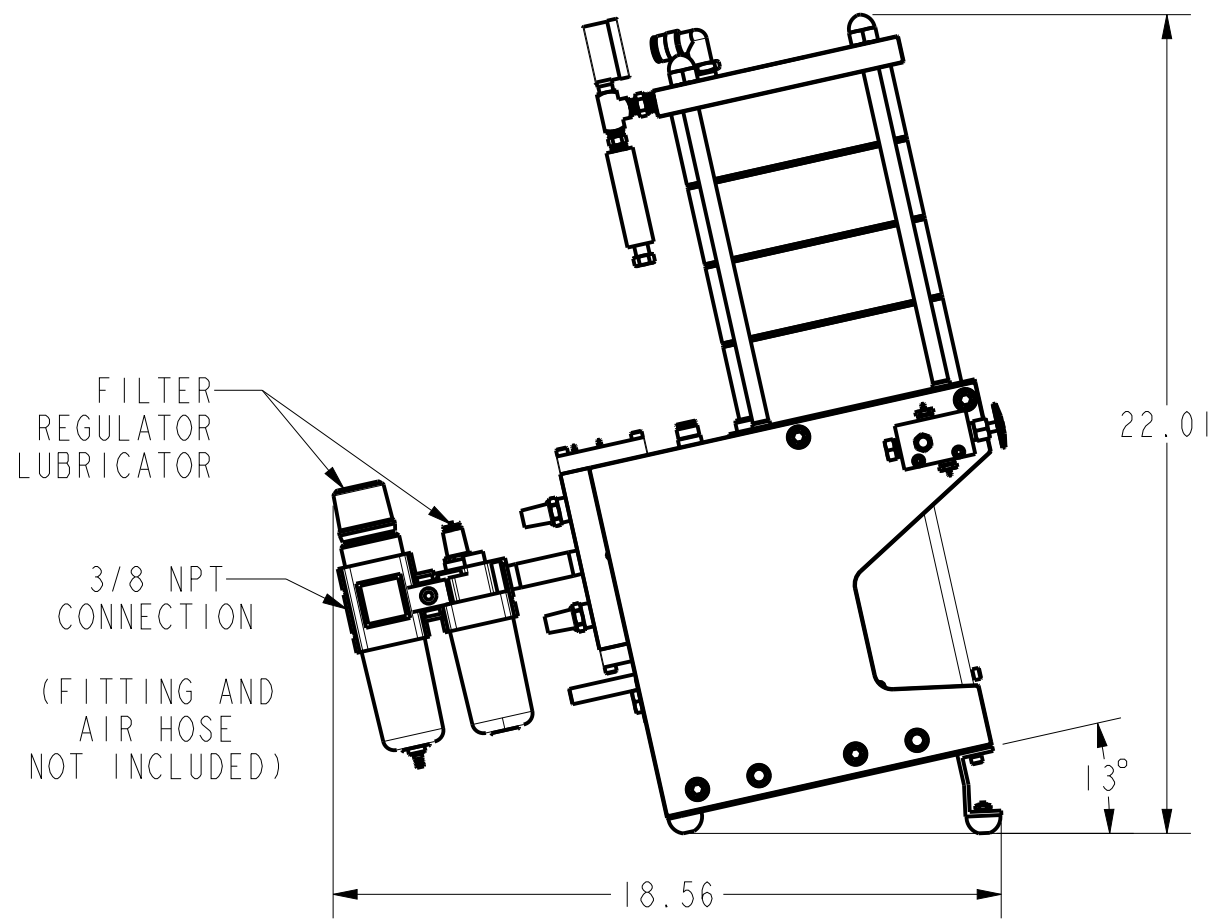

"RAM UP"
VALVE WITH
EMERGENCY STOP

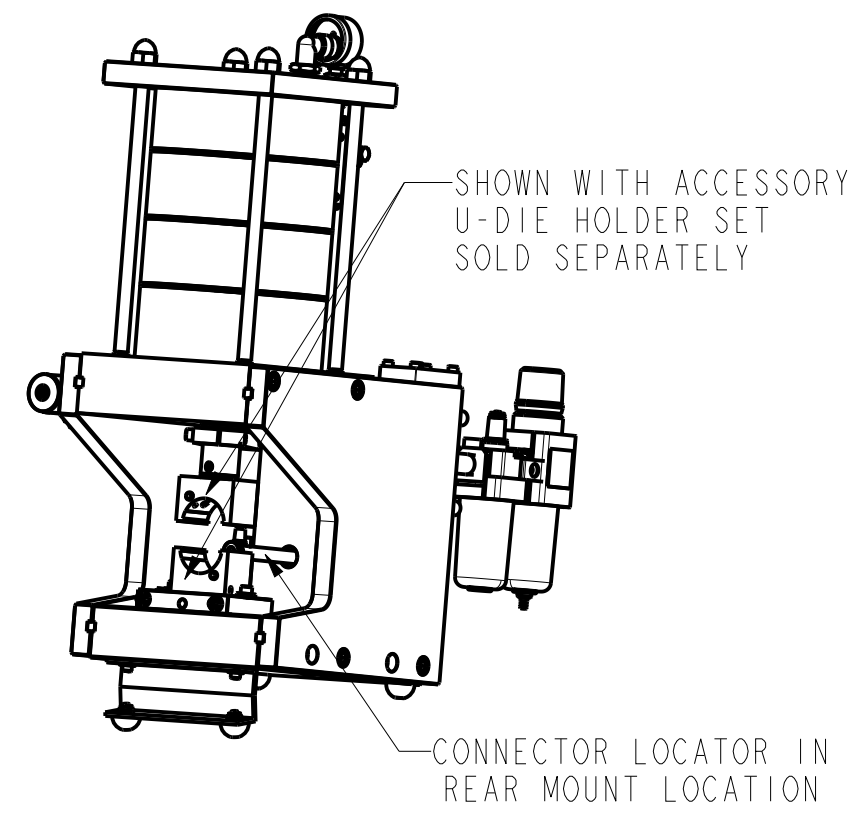
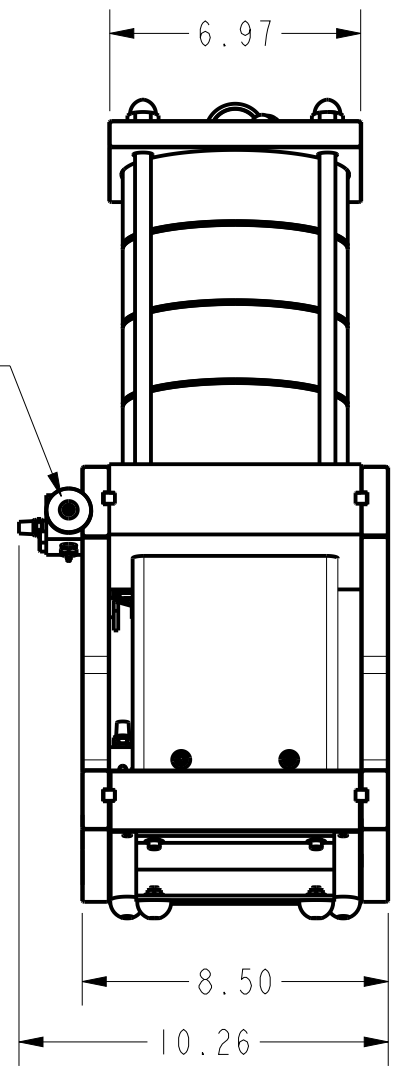

SHOWN WITH ACCESSORY
U-DIE HOLDER SET
SOLD SEPARATELY

CONNECTOR LOCATOR IN
SIDE MOUNT LOCATION

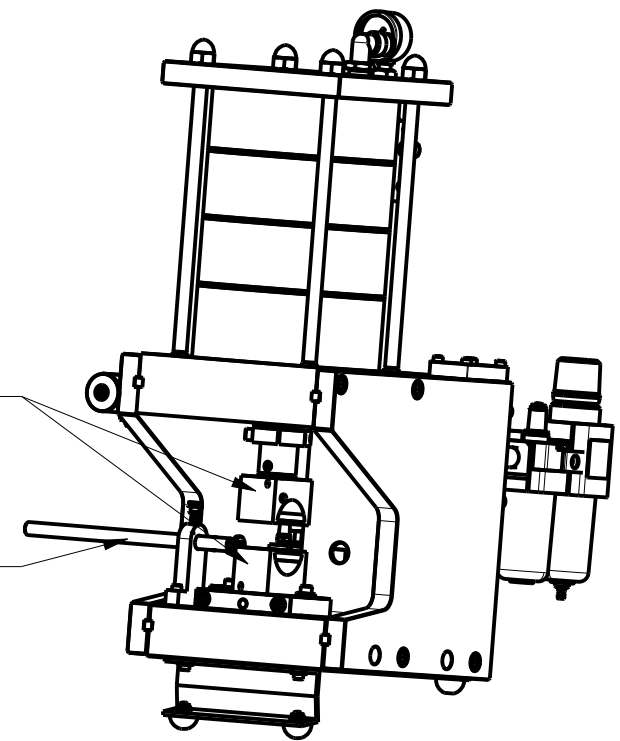

OEM840NCP SPECIFICATIONS
 WEIGHT: 61 LBS (EST. BASE TOOL)
 OPERATING PRESSURE: 90-100 PSI
 RAM TRAVEL: 1.125 INCH
 OUTPUT: 4.5 TONS

FEATURES & BENEFITS:
 ONE STEP FOOT ACTIVATED CRIMP - LEAVES HANDS FREE TO INSERT CONNECTOR INTO PRESS
 PRESSURE REGULATED - CONTROLS CRIMP FORCE
 LOW LIMIT PRESSURE REGULATED SWITCH - PRESS WILL NOT COMPLETE IT'S CYCLE WHEN SUPPLY PRESSURE IS LOW
 ROBUST DESIGN - HIGHLY RELIABLE WITH VERY LOW MAINTENANCE
 FRONT SAFETY GUARD WITH SWITCH INTERLOCK - SAFE OPERATION OF TOOL FOR USER
 L-SHAPED RISER BRACKET - OPTIONAL FEEDING ANGLE AND CAN BE SECURED TO BENCH TOP
 USES BURNDY® W-DIES - ACCOMODATES CONNECTOR SIZES TO 1/0 AWG COPPER WITH W-DIE HOLDERS
 USES BURNDY® U-NEST & INDENTOR DIE - ACCOMODATES CONNECTOR SIZES UP TO 4/0 COPPER
 USES BURNDY® U-DIES - ACCOMODATES CONNECTOR SIZES TO 2 AWG COPPER
 USES BURNDY® U-M (DOUBLE INDENT) DIES - ACCOMODATES CONNECTOR SIZES UP TO 4/0 AWG COPPER
 COUNTER DEVICE - STORES THE NUMBER OF RAM ACTUATIONS

TO ORDER BURNDY® PRODUCTS CALL
 UNITED STATES:
 1-800-346-4175 (LONDONDERRY, NH)
 CANADA:
 1-800-361-6975 (QUEBEC)
 1-800-387-6487 (ALL OTHER PROVINCES)
 FOR PRODUCT INFO: <http://www.burndy.com>

PNEUMATIC PRESS, 4.5 TON	
ITEM NO: 50024686	
CAT. NO: OEM840NCP	
DRAWN BY: T. FAUCHER 10/23/2013	
CHECKER: B. VACHON 10/23/2013	
DSN APPVL: J. LEFAVOUR 11/12/2013	
MFG APPVL: S. HOPPS 11/12/2013	
QA APPVL: C. LINDQUIST 11/12/2013	
MKT APPVL: R. PIOTROWSKI 11/12/2013	
PROD FAM: TOOLS, PNEUMATIC	DRAWING NO: 50024706
PROJECT #: 14508	SIZE: B
DOCUMENT TYPE: Sales	REV: B
REL LEVEL: Released	SHEET 1 OF 1



REV: PE0200