

CATALOG NO.	CONDUCTOR	BOLT SIZE	INSTALLATION TOOLING (# CRIMPS)					DIELESS (# CRIMPS)	WIRE STRIP LENGTH
			DIE INDEX	COLOR CODE	HYDRAULIC				
					Y750 Y35 Y39	Y46 4	Y45 3		
YA40LENT12FX	646 WELD 1600/24 650 kcmil CLASS B,C,D,G,H,I,K,M	1/2	24	BLACK	U39RT (2)	U39RT (2)	U39RT (2)	HYDRAULIC: Y644M (1) PAT644 (1) Y81KFT (2) PAT81KFT (3) Y4PC834 (3) PAT4PC834 (3)	1-5/16"

REV	DATE	DESCRIPTION	ECO	BY	C'H'K.
A	07/10/2013	RELEASE SALES DRAWING	32377	RG	VK

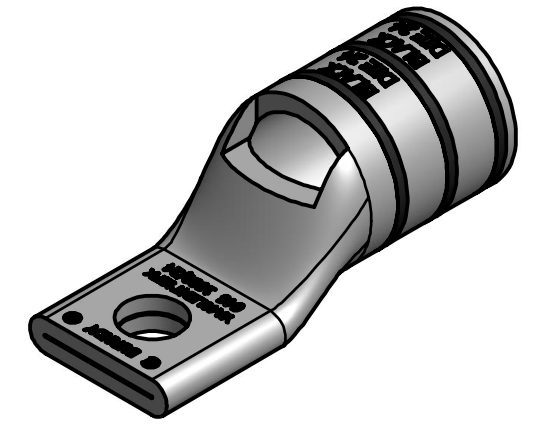
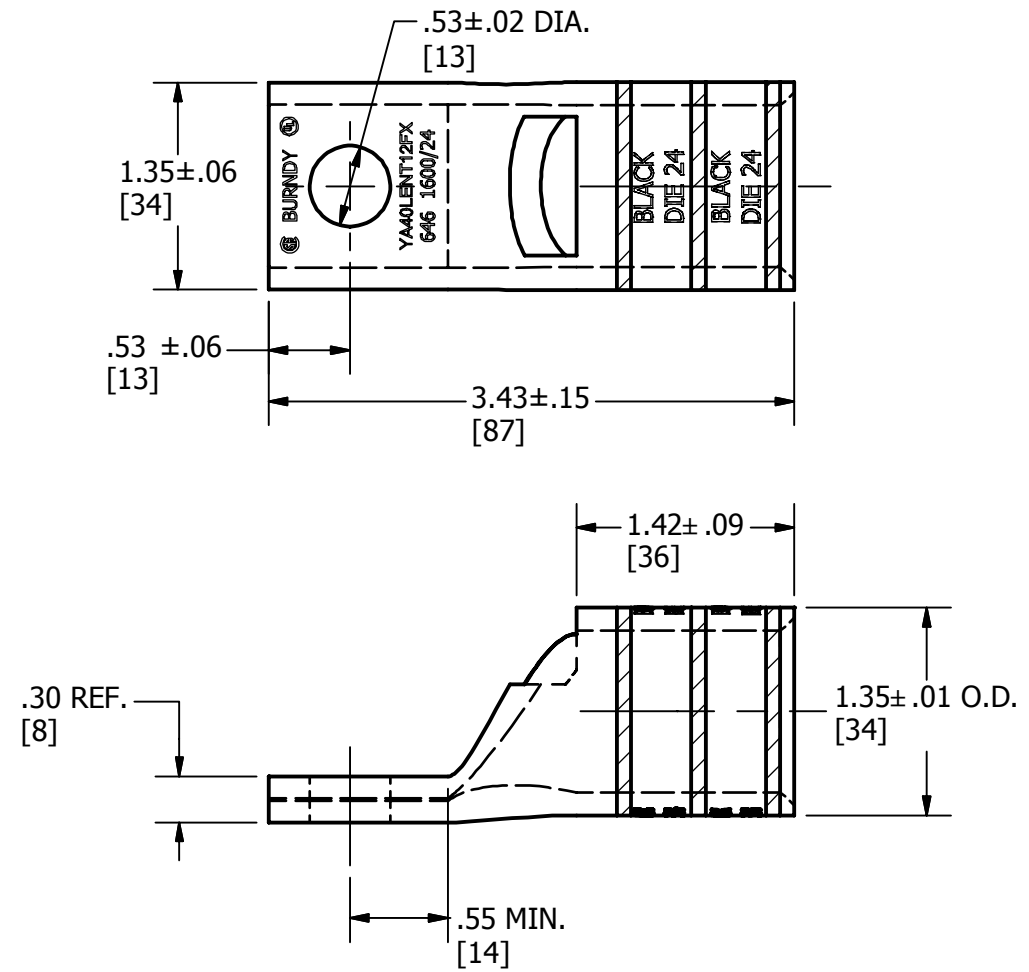

NOTES:

1. MATERIAL: COPPER TUBING.
2. FINISH: TIN PLATED.
3. CATALOG # PT6515 ADAPTOR IS REQUIRED TO USE "U" DIES IN Y45 SERIES TOOLS.
4. CATALOG # PUADP-1 ADAPTOR IS REQUIRED TO USE "U" DIES IN Y46 SERIES TOOLS.
5. DIMENSIONS IN BRACKETS [ ] ARE IN MILLIMETERS ROUNDED OFF TO THE NEAREST MILLIMETER, UNLESS OTHERWISE SPECIFIED AND ARE FOR REFERENCE ONLY.

TO ORDER BURNDY® PRODUCTS CALL		HYLUG™																	
UNITED STATES 1-800-346-4175 (LONDONDERRY, NH)		ITEM NO: 50025225																	
CANADA: 1-800-361-6975 (QUEBEC) 1-800-387-6487 (ALL OTHER PROVINCES)		CAT. NO: YA40LENT12FX																	
FOR PRODUCT INFO: <a href="http://www.burndy.com">http://www.burndy.com</a>		<table border="1"> <tr> <td>DRAWN BY: YUNARAJ.M</td> <td>5/16/2013</td> </tr> <tr> <td>CHECKER: J. MICHAUD</td> <td>7/23/2013</td> </tr> <tr> <td>DSN APRVL: J. MICHAUD</td> <td>7/23/2013</td> </tr> <tr> <td>MFG APRVL: M. KNAPTON</td> <td>7/24/2013</td> </tr> <tr> <td>QA APRVL: T. WATTS</td> <td>7/18/2013</td> </tr> <tr> <td>MKT APRVL: J. SYLVIA</td> <td>7/25/2013</td> </tr> </table>		DRAWN BY: YUNARAJ.M	5/16/2013	CHECKER: J. MICHAUD	7/23/2013	DSN APRVL: J. MICHAUD	7/23/2013	MFG APRVL: M. KNAPTON	7/24/2013	QA APRVL: T. WATTS	7/18/2013	MKT APRVL: J. SYLVIA	7/25/2013				
DRAWN BY: YUNARAJ.M	5/16/2013																		
CHECKER: J. MICHAUD	7/23/2013																		
DSN APRVL: J. MICHAUD	7/23/2013																		
MFG APRVL: M. KNAPTON	7/24/2013																		
QA APRVL: T. WATTS	7/18/2013																		
MKT APRVL: J. SYLVIA	7/25/2013																		
<table border="1"> <tr> <td>PROJ #:</td> <td>SIZE</td> <td>DRAWING NO</td> <td>REV</td> </tr> <tr> <td>PROJECT #:</td> <td></td> <td>50025226</td> <td>A</td> </tr> <tr> <td>DOCUMENT TYPE: SALES</td> <td>B</td> <td colspan="2">SHEET 1 OF 1</td> </tr> <tr> <td>REL LEVEL: Released</td> <td></td> <td colspan="2"></td> </tr> </table>		PROJ #:	SIZE	DRAWING NO	REV	PROJECT #:		50025226	A	DOCUMENT TYPE: SALES	B	SHEET 1 OF 1		REL LEVEL: Released					
PROJ #:	SIZE	DRAWING NO	REV																
PROJECT #:		50025226	A																
DOCUMENT TYPE: SALES	B	SHEET 1 OF 1																	
REL LEVEL: Released																			