

REV	DATE	DESCRIPTION	ECO	BY	C'H'K.
B	11/09/2021	UPDATED PRODUCT TABLES	211104014086	JL	RR

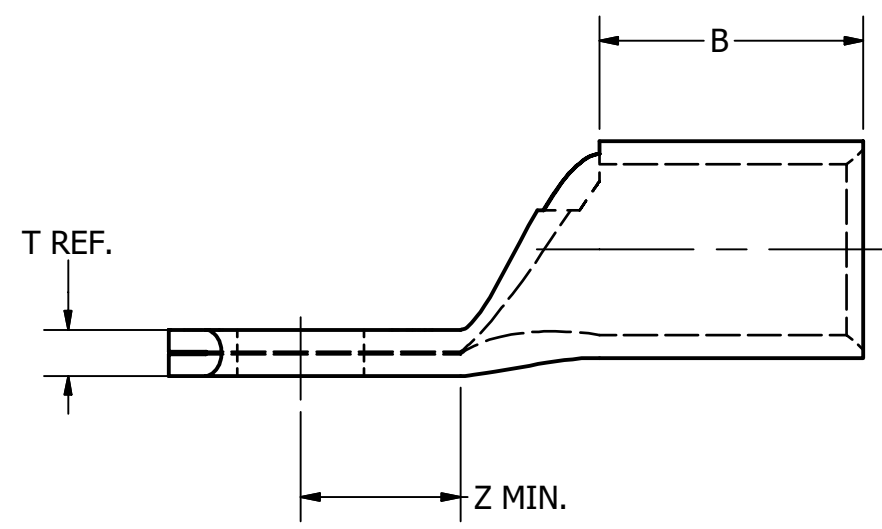
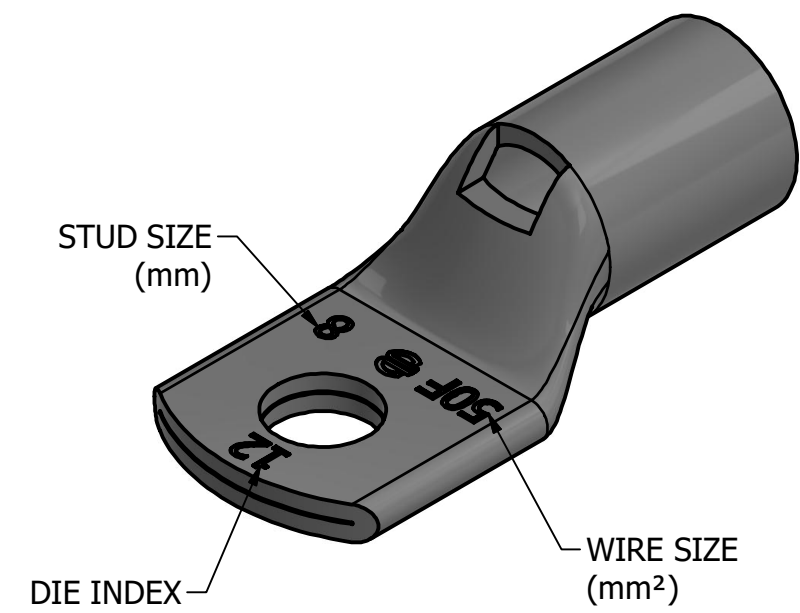
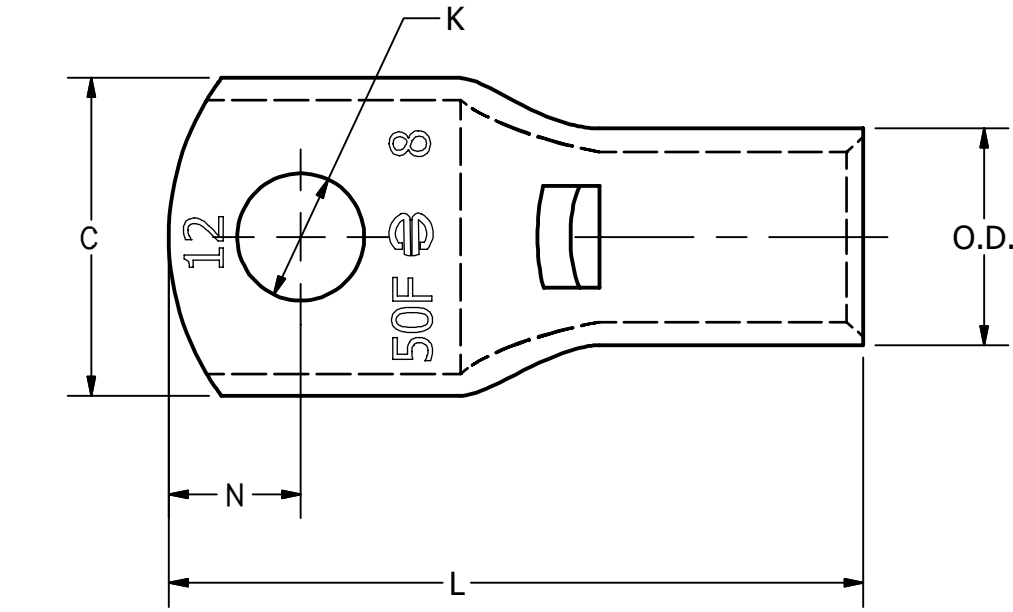

NOTES:

1. MATERIAL: COPPER TUBING.
2. FINISH: TIN PLATED.
3. DIMENSIONS IN BRACKETS [] ARE IN INCHES ROUNDED OFF TO THE NEAREST HUNDRETH, UNLESS OTHERWISE NOTED, AND ARE FOR REFERENCE ONLY.
4. CONNECTORS ARE COMPATIBLE WITH THE FOLLOWING STANDARDS:
IEC-61238-1, UL486A/B (USA), CSA-C22.2 No 65-03 (CANADA)
5. CATALOG # PUDAP-1 ADAPTOR IS REQUIRED TO USE 'U' DIES IN Y46 SERIES TOOLS.
6. USE THE EQUIVALENT AWG SETTING ON TOOL FOR INSTALLATION.

TO ORDER BURNDY® PRODUCTS CALL		HYLUG™	
UNITED STATES 1-800-346-4175 (LONDONDERRY, NH)		ITEM NO: --	CAT. NO: SEE TABLE
CANADA: 1-800-387-6487		DRAWN BY: B.PARTHIBAN 05/23/2013	CHECKER: R.ROMAN 06/04/2013
FOR PRODUCT INFO: http://www.burndy.com		DSN APRVL: R.ROMAN 06/04/2013	MFG APRVL: --
		QA APRVL: T.WATTS 06/05/2013	MKT APRVL: J.SYLVIA 06/04/2013
		PROD FAM:	DRAWING NO
		PROJECT #:	50025612
		DOCUMENT TYPE: SALES	REV
		REL LEVEL: Released	B
		SIZE	B
		SHEET 1 OF 4	



CATALOG NUMBER	COPPER CONDUCTOR		BOLT SIZE	DIMENSIONS								DIE INDEX	INSTALLATION TOOLING (# OF CRIMPS)				WIRE STRIP LENGTH (mm)
	SIZE mm ² (AWG)	CLASS		B	C	K	L	N	O.D.	T REF.	Z MIN.		MECHANICAL	HYDRAULIC		DIELESS (# OF CRIMPS)	
													MD6, OUR840 MD7-34R	PAT600, Y500CHS	Y35, Y39, Y750, Y46 PAT750		
YAV50FM6	50 (1/0)	5	M6	17.5 [.69]	21.1 [.83]	6.9 [.27]	44.5 [1.75]	7.9 [.31]	14.2 [.56]	3.0 [.12]	8.4 [.33]	12	W25VT (2) W25RT (2) X25RT (2)	W25VT (2) W25RT (2) X25RT (2)	U25RT (1)	MY29-11 (1) MRC840 (2) Y644 (1) PAT644 (1) Y81KFT (1) PAT81KFT (1)	19
YAV50FM8	50 (1/0)	5	M8	17.5 [.69]	21.1 [.83]	8.4 [.33]	46.0 [1.81]	8.6 [.34]	14.2 [.56]	3.0 [.12]	9.1 [.36]						
YAV50FM10	50 (1/0)	5	M10	17.5 [.69]	21.1 [.83]	10.4 [.41]	49.3 [1.94]	10.4 [.41]	14.2 [.56]	3.0 [.12]	10.7 [.42]						
YAV50FM12	50 (1/0)	5	M12	17.5 [.69]	21.1 [.83]	13.5 [.53]	55.6 [2.19]	13.5 [.53]	14.2 [.56]	3.0 [.12]	14.0 [.55]						
YAV50FM14	50 (1/0)	5	M14	17.5 [.69]	22.4 [.88]	15.0 [.59]	56.6 [2.23]	14.0 [.55]	14.2 [.56]	3.0 [.12]	14.5 [.57]						
YAV50FM16	50 (1/0)	5	M16	17.5 [.69]	22.4 [.88]	17.5 [.69]	61.9 [2.44]	16.8 [.66]	14.2 [.56]	3.0 [.12]	17.0 [.67]						
YAV70FM6	70 (2/0)	5	M6	20.6 [.81]	23.6 [.93]	6.9 [.27]	49.0 [1.92]	7.9 [.31]	16.0 [.63]	3.3 [.13]	8.4 [.33]	13	W26RT (2) X26RT (2) W26VT (2)	W26RT (2) X26RT (2) W26VT (2)	U26RT (1)	MY29-11 (1) MRC840 (2) Y644 (1) PAT644 (1) Y81KFT (1) PAT81KFT (1)	22
YAV70FM8	70 (2/0)	5	M8	20.6 [.81]	23.6 [.93]	8.4 [.33]	50.3 [1.98]	8.6 [.34]	16.0 [.63]	3.3 [.13]	9.1 [.36]						
YAV70FM10	70 (2/0)	5	M10	20.6 [.81]	23.6 [.93]	10.4 [.41]	54.0 [2.11]	10.4 [.41]	16.0 [.63]	3.3 [.13]	10.7 [.42]						
YAV70FM12	70 (2/0)	5	M12	20.6 [.81]	23.6 [.93]	13.0 [.53]	60.0 [2.36]	13.0 [.53]	16.0 [.63]	3.3 [.13]	14.0 [.55]						
YAV70FM14	70 (2/0)	5	M14	20.6 [.81]	23.6 [.93]	15.0 [.59]	61.0 [2.40]	14.0 [.55]	16.0 [.63]	3.3 [.13]	14.5 [.57]						
YAV70FM16	70 (2/0)	5	M16	20.6 [.81]	23.6 [.93]	17.5 [.69]	66.3 [2.61]	16.8 [.66]	16.0 [.63]	3.3 [.13]	17.0 [.67]						
YAV95FM8	95 (3/0)	5	M8	25.0 [1.00]	26.0 [1.03]	8.4 [.33]	56.0 [2.21]	8.6 [.34]	18.0 [.70]	4.0 [.14]	9.1 [.36]	14	W27VT (2) W27RT (2) X27RT (3)	W27VT (2) W27RT (2) X27RT (3)	U27RT (1)	MY29-11 (1) MRC840 (2) Y644 (1) PAT644 (1) Y81KFT (2) PAT81KFT (2)	27
YAV95FM10	95 (3/0)	5	M10	25.0 [1.00]	26.0 [1.03]	10.4 [.41]	59.0 [2.34]	10.4 [.41]	18.0 [.70]	4.0 [.14]	10.7 [.42]						
YAV95FM12	95 (3/0)	5	M12	25.0 [1.00]	26.0 [1.03]	13.0 [.53]	66.0 [2.59]	13.0 [.53]	18.0 [.70]	4.0 [.14]	14.0 [.55]						
YAV95FM14	95 (3/0)	5	M14	25.0 [1.00]	26.0 [1.03]	15.0 [.59]	66.8 [2.63]	14.0 [.55]	18.0 [.70]	4.0 [.14]	14.5 [.57]						
YAV95FM16	95 (3/0)	5	M16	25.0 [1.00]	26.0 [1.03]	17.5 [.69]	72.1 [2.84]	16.8 [.66]	18.0 [.70]	4.0 [.14]	17.0 [.67]						
YAV95FM20	95 (3/0)	5	M20	25.0 [1.00]	26.0 [1.03]	23.8 [.94]	83.2 [3.28]	22.4 [.88]	18.0 [.70]	4.0 [.14]	22.6 [.89]						

REV	DATE	DESCRIPTION	ECO	BY	C'H'K.
B	11/09/2021	UPDATED PRODUCT TABLES	211104014086	JL	RR

CONNECTOR SIZE	TOLERANCES					
	B	C	K DIA.	L	N	O.D.
015 - 6	± .8 [.03]	± 1.0 [.04]	± .5 [.02]	± 1.5 [.06]	± .8 [.03]	± .3 [.01]
10 - 50	± 1.5 [.06]	± 1.0 [.04]	± .5 [.02]	± 2.3 [.09]	± .8 [.03]	± .3 [.01]
70 - 240	± 2.0 [.08]	± 1.0 [.04]	± .5 [.02]	± 3.0 [.12]	± .8 [.03]	± .3 [.01]
300 & ABOVE	± 2.3 [.09]	± 1.5 [.06]	± .5 [.02]	± 3.8 [.15]	± 1.5 [.06]	± .3 [.01]

NOTES:
1. SEE SHEET 1 FOR NOTES.

TO ORDER BURNDY® PRODUCTS CALL		HYLUG™	
UNITED STATES 1-800-346-4175 (LONDONDERRY, NH)		ITEM NO: --	
CANADA: 1-800-387-6487		CAT. NO: SEE TABLE	
FOR PRODUCT INFO: http://www.burndy.com		DRAWN BY: B.PARTHIBAN 05/23/2013	
		CHECKER: R.ROMAN 06/04/2013	
		DSN APRVL: R.ROMAN 06/04/2013	
		MFG APRVL: --	
		QA APRVL: T.WATTS 06/05/2013	
		MKT APRVL: J.SYLVIA 06/04/2013	
		PROJ FAM: --	
		DRAWING NO: 50025612	
		REV: B	
		SHEET 2 OF 4	



CATALOG NUMBER	COPPER CONDUCTOR		BOLT SIZE	DIMENSIONS								DIE INDEX	INSTALLATION TOOLING (# OF CRIMPS)				WIRE STRIP LENGTH (mm)
	SIZE mm ² (AWG)	CLASS		B	C	K	L	N	O.D.	T REF.	Z MIN.		MECHANICAL	HYDRAULIC		DIELESS (# OF CRIMPS)	
													MD6, OUR840 MD7-34R	PAT600, Y500CTHS	Y35, Y39, Y750, Y46 PAT750		
YAV120FM8	120 (4/0)	5	M8	26.2 [1.03]	29.0 [1.14]	8.4 [.33]	58.2 [2.29]	8.6 [.34]	19.6 [.77]	3.8 [.15]	9.1 [.36]	15	W28VT (2) W28RT (2) X28RT (3)	W28VT (2) W28RT (2) X28RT (3)	U28RT (1)	MY29-11 (1) MRC840 (2) Y644 (1) PAT644 (1) Y81KFT (2) PAT81KFT (2)	27
YAV120FM10	120 (4/0)	5	M10	26.2 [1.03]	29.0 [1.14]	10.4 [.41]	61 [2.42]	10.4 [.41]	19.6 [.77]	3.8 [.15]	10.7 [.42]						
YAV120FM12	120 (4/0)	5	M12	26.2 [1.03]	29.0 [1.14]	13.0 [.53]	68 [2.67]	13.0 [.53]	19.6 [.77]	3.8 [.15]	14.0 [.55]						
YAV120FM14	120 (4/0)	5	M14	26.2 [1.03]	29.0 [1.14]	15.0 [.59]	68.8 [2.71]	14.0 [.55]	19.6 [.77]	3.8 [.15]	14.5 [.57]						
YAV120FM16	120 (4/0)	5	M16	26.2 [1.03]	29.0 [1.14]	17.5 [.69]	74.1 [2.92]	16.8 [.66]	19.6 [.77]	3.8 [.15]	17.0 [.67]						
YAV120FM20	120 (4/0)	5	M20	26.2 [1.03]	29.0 [1.14]	23.8 [.94]	85.2 [3.36]	22.4 [.88]	19.6 [.77]	3.8 [.15]	22.6 [.89]						
YAV150FM8	150 (250)	5	M8	26.9 [1.06]	32.8 [1.29]	8.4 [.33]	60.2 [2.37]	8.6 [.34]	22.4 [.88]	4.6 [.18]	9.1 [.36]	17	W30VT (2)	W30VT (2) W30RT (2)	U30RT (2)	Y644 (1) PAT644 (1) Y81KFT (2) PAT81KFT (2)	29
YAV150FM10	150 (250)	5	M10	26.9 [1.06]	32.8 [1.29]	10.4 [.41]	64.0 [2.50]	7.1 [.28]	22.4 [.88]	4.6 [.18]	10.7 [.42]						
YAV150FM12	150 (250)	5	M12	26.9 [1.06]	32.8 [1.29]	13.5 [.53]	70.0 [2.75]	9.7 [.38]	22.4 [.88]	4.6 [.18]	14.0 [.55]						
YAV150FM14	150 (250)	5	M14	26.9 [1.06]	32.8 [1.29]	15.0 [.59]	70.8 [2.79]	14.0 [.55]	22.4 [.88]	4.6 [.18]	14.5 [.57]						
YAV150FM16	150 (250)	5	M16	26.9 [1.06]	32.8 [1.29]	17.5 [.69]	76.0 [3.00]	16.8 [.66]	22.4 [.88]	4.6 [.18]	17.0 [.67]						
YAV150FM20	150 (250)	5	M20	26.9 [1.06]	32.8 [1.29]	23.8 [.94]	87.3 [3.44]	22.4 [.88]	22.4 [.88]	4.6 [.18]	22.6 [.89]						
YAV185FM8	185 (313)	5	M8	30.2 [1.19]	35.6 [1.40]	8.4 [.33]	64.8 [2.55]	6.9 [.27]	24.1 [.95]	5.0 [.19]	9.1 [.36]	18	W31VT (2)	W31VT (2) W31RT (2)	U31RT (2)	Y644 (1) PAT644 (1) Y81KFT (2) PAT81KFT (2)	29
YAV185FM10	185 (313)	5	M10	30.2 [1.19]	35.6 [1.40]	10.4 [.41]	68.0 [2.68]	7.1 [.28]	24.1 [.95]	5.0 [.19]	10.7 [.42]						
YAV185FM12	185 (313)	5	M12	30.2 [1.19]	35.6 [1.40]	13.5 [.53]	74.0 [2.93]	9.7 [.38]	24.1 [.95]	5.0 [.19]	14.0 [.55]						
YAV185FM14	185 (313)	5	M14	30.2 [1.19]	35.6 [1.40]	15.0 [.59]	75.4 [2.97]	14.0 [.55]	24.1 [.95]	5.0 [.19]	14.5 [.57]						
YAV185FM16	185 (313)	5	M16	30.2 [1.19]	35.6 [1.40]	17.5 [.69]	81.0 [3.18]	16.8 [.66]	24.1 [.95]	5.0 [.19]	17.0 [.67]						
YAV185FM20	185 (313)	5	M20	30.2 [1.19]	35.6 [1.40]	23.8 [.94]	91.8 [3.62]	22.4 [.88]	24.1 [.95]	5.0 [.19]	22.6 [.89]						

REV	DATE	DESCRIPTION	ECO	BY	C'H'K.
B	11/09/2021	UPDATED PRODUCT TABLES	211104014086	JL	RR

CONNECTOR SIZE	TOLERANCES					
	B	C	K DIA.	L	N	O.D.
015 - 6	± .8 [.03]	± 1.0 [.04]	± .5 [.02]	± 1.5 [.06]	± .8 [.03]	± .3 [.01]
10 - 50	± 1.5 [.06]	± 1.0 [.04]	± .5 [.02]	± 2.3 [.09]	± .8 [.03]	± .3 [.01]
70 - 240	± 2.0 [.08]	± 1.0 [.04]	± .5 [.02]	± 3.0 [.12]	± .8 [.03]	± .3 [.01]
300 & ABOVE	± 2.3 [.09]	± 1.5 [.06]	± .5 [.02]	± 3.8 [.15]	± 1.5 [.06]	± .3 [.01]

NOTES:

1. SEE SHEET 1 FOR NOTES.

TO ORDER BURNDY® PRODUCTS CALL
 UNITED STATES
 1-800-346-4175 (LONDONDERRY, NH)
 CANADA:
 1-800-387-6487
 FOR PRODUCT INFO: <http://www.burndy.com>

HYLUG™	
ITEM NO: --	
CAT. NO: SEE TABLE	
DRAWN BY: B.PARTHIBAN 05/23/2013	
CHECKER: R.ROMAN 06/04/2013	
DSN APRVL: R.ROMAN 06/04/2013	
MFG APRVL: --	
QA APRVL: T.WATTS 06/05/2013	
MKT APRVL: J.SYLVIA 06/04/2013	
PROD FAM:	DRAWING NO
PROJECT #:	SIZE
DOCUMENT TYPE: SALES	B
REL LEVEL: Released	
	50025612
	SHEET 3 OF 4
	B



CATALOG NUMBER	COPPER CONDUCTOR		BOLT SIZE	DIMENSIONS								DIE INDEX	INSTALLATION TOOLING (# OF CRIMPS)				WIRE STRIP LENGTH (mm)
	SIZE mm ² (AWG)	CLASS		B	C	K	L	N	O.D.	T REF.	Z MIN.		MECHANICAL	HYDRAULIC		DIELESS (# OF CRIMPS) 	
													MD6, OUR840 MD7-34R	PAT600, Y500CTHS	Y35, Y39, Y750, Y46 PAT750		
YAV240FM10	240	5	M10	32.3 [1.27]	39.4 [1.55]	10.4 [41]	72.9 [2.87]	10.4 [41]	26.9 [1.06]	5.8 [23]	10.7 [42]	20	--	--	U34RT (2)	Y644 (1) PAT644 (1) Y81KFT (2) PAT81KFT (2)	33
YAV240FM12	240	5	M12	32.3 [1.27]	39.4 [1.55]	13.5 [53]	79.0 [3.12]	9.7 [38]	26.9 [1.06]	5.8 [23]	14.0 [55]						
YAV240FM14	240	5	M14	32.3 [1.27]	39.4 [1.55]	15.0 [59]	80.2 [3.16]	14.0 [55]	26.9 [1.06]	5.8 [23]	14.5 [57]						
YAV240FM16	240	5	M16	32.3 [1.27]	39.4 [1.55]	17.5 [69]	85.5 [3.37]	16.8 [66]	26.9 [1.06]	5.8 [23]	17.0 [67]						
YAV240FM20	240	5	M20	32.3 [1.27]	39.4 [1.55]	23.8 [94]	96.6 [3.80]	22.4 [88]	26.9 [1.06]	5.8 [23]	22.6 [89]						
YAV300FM10	300	5	M10	37.0 [1.45]	47.0 [1.84]	10.4 [41]	80.2 [3.16]	7.1 [28]	32.0 [1.25]	7.0 [27]	10.7 [42]	22	--	--	U36RT (2)	Y644 (1) PAT644 (1) Y81KFT (2) PAT81KFT (2)	38
YAV300FM12	300	5	M12	37.0 [1.45]	47.0 [1.84]	13.5 [53]	87.0 [3.41]	9.7 [38]	32.0 [1.25]	7.0 [27]	14.0 [55]						
YAV300FM14	300	5	M14	37.0 [1.45]	47.0 [1.84]	15.0 [59]	87.5 [3.45]	14.0 [55]	32.0 [1.25]	7.0 [27]	14.5 [57]						
YAV300FM16	300	5	M16	37.0 [1.45]	47.0 [1.84]	17.5 [69]	93.0 [3.66]	16.8 [66]	32.0 [1.25]	7.0 [27]	17.0 [67]						
YAV300FM20	300	5	M20	37.0 [1.45]	47.0 [1.84]	23.8 [94]	104.0 [4.09]	22.4 [88]	32.0 [1.25]	7.0 [27]	22.6 [89]						
YAV400FM12	400	5	M12	36.1 [1.42]	50.3 [1.98]	13.5 [53]	87.0 [3.43]	9.7 [38]	34.3 [1.35]	7.6 [30]	14.0 [55]	24	--	--	U39RT (3)	Y644 (1) PAT644 (1) Y81KFT (3) PAT81KFT (3)	37
YAV400FM14	400	5	M14	36.1 [1.42]	50.3 [1.98]	15.0 [59]	88.1 [3.47]	14.0 [55]	34.3 [1.35]	7.6 [30]	14.5 [57]						
YAV400FM16	400	5	M16	36.1 [1.42]	50.3 [1.98]	17.5 [69]	93.5 [3.68]	16.8 [66]	34.3 [1.35]	7.6 [30]	17.0 [67]						
YAV400FM20	400	5	M20	36.1 [1.42]	50.3 [1.98]	23.8 [94]	104.5 [4.12]	22.4 [88]	34.3 [1.35]	7.6 [30]	22.6 [89]						
YAV500FM12	500	5	M12	41.9 [1.65]	55.6 [2.19]	13.5 [53]	96.0 [3.79]	9.7 [38]	38.1 [1.50]	8.4 [33]	14.0 [55]	L115	--	--	U44XRT (3)	Y644 (1) PAT644 (1) Y81KFT (3) PAT81KFT (3)	43
YAV500FM16	500	5	M16	41.9 [1.65]	55.6 [2.19]	17.5 [69]	102.6 [4.04]	16.8 [66]	38.1 [1.50]	8.4 [33]	17.0 [67]						
YAV500FM20	500	5	M20	41.9 [1.65]	55.6 [2.19]	23.8 [94]	113.7 [4.48]	22.4 [88]	38.1 [1.50]	8.4 [33]	22.6 [89]						
YAV630FM12	630	5	M12	50.8 [2.00]	68.3 [2.69]	13.5 [53]	110.2 [4.34]	9.7 [38]	46.7 [1.84]	9.9 [39]	14.0 [55]	31	--	--	P46RT (3)	--	55
YAV630FM16	630	5	M16	50.8 [2.00]	68.3 [2.69]	17.5 [69]	116.6 [4.59]	16.8 [66]	46.7 [1.84]	9.9 [39]	17.0 [67]						
YAV630FM20	630	5	M20	50.8 [2.00]	68.3 [2.69]	23.8 [94]	127.7 [5.03]	22.4 [88]	46.7 [1.84]	9.9 [39]	22.6 [89]						

REV	DATE	DESCRIPTION	ECO	BY	C'H'K.
B	11/09/2021	UPDATED PRODUCT TABLES	211104014086	JL	RR

CONNECTOR SIZE	TOLERANCES					
	B	C	K DIA.	L	N	O.D.
015 - 6	± .8 [.03]	± 1.0 [.04]	± .5 [.02]	± 1.5 [.06]	± .8 [.03]	± .3 [.01]
10 - 50	± 1.5 [.06]	± 1.0 [.04]	± .5 [.02]	± 2.3 [.09]	± .8 [.03]	± .3 [.01]
70 - 240	± 2.0 [.08]	± 1.0 [.04]	± .5 [.02]	± 3.0 [.12]	± .8 [.03]	± .3 [.01]
300 & ABOVE	± 2.3 [.09]	± 1.5 [.06]	± .5 [.02]	± 3.8 [.15]	± 1.5 [.06]	± .3 [.01]

NOTES:
1. SEE SHEET 1 FOR NOTES.

TO ORDER BURNDY® PRODUCTS CALL		HYLUG™	
UNITED STATES 1-800-346-4175 (LONDONDERRY, NH)		ITEM NO: -- CAT. NO: SEE TABLE	
CANADA: 1-800-387-6487		DRAWN BY: B.PARTHIBAN 05/23/2013 CHECKER: R.ROMAN 06/04/2013 DSN APRVL: R.ROMAN 06/04/2013 MFG APRVL: -- QA APRVL: T.WATTS 06/05/2013 MKT APRVL: J.SYLVA 06/04/2013	
FOR PRODUCT INFO: http://www.burndy.com			
PROJ #:	SIZE	DRAWING NO	REV
DOCUMENT TYPE: SALES	B	50025612	B
REL LEVEL: Released		SHEET 4 OF 4	