

NONMETALLIC CABLE TIES

REV	DATE	DESCRIPTION	ECO	BY	C'H.K.
D	05/11/2015	DRAWING RELEASED	39898	SPR	MB

BURNDY ITEM NUMBER	BURNDY CATALOG NUMBER	CABLE TIE CONFIG	UL TYPE DESIGNATION	TENSILE lb / [N]	MATERIAL	COLOR	BUNDLE DIA MIN IN / [MM]	BUNDLE DIA MAX IN / [MM]	L IN / [MM]	W IN / [MM]	MIN INSTALL TEMP F / C	MIN OPER TEMP F / C	MAX OPER TEMP F / C	PACKAGE QTY	BAG LENGTH +/- .25	BAG WIDTH +/- .25
10023575	CT250600Q	FIG. 1	TYPE 2/21	250 / [1112]	NYLON 6/6	NATURAL	1.50 / [38]	6.00 / [152]	22 / [559]	0.5 / [13]	32 / 0	-40 / -40	185 / 85	25		
10023586	CT250800Q	FIG. 1	TYPE 2/21	250 / [1112]	NYLON 6/6	NATURAL	1.50 / [38]	8.00 / [203]	29 / [737]	0.5 / [13]	32 / 0	-40 / -40	185 / 85	25		
10023597	CT2501000Q	FIG. 1	TYPE 2/21	250 / [1112]	NYLON 6/6	NATURAL	1.50 / [38]	10.00 / [254]	35 / [889]	0.5 / [13]	32 / 0	-40 / -40	185 / 85	25		
10023619	CT250600Q0	FIG. 1	TYPE 2/21	250 / [1112]	NYLON 6/6	UV BLACK	1.50 / [38]	6.00 / [152]	22 / [559]	0.5 / [13]	32 / 0	-40 / -40	185 / 85	25		
10023620	CT250800Q0	FIG. 1	TYPE 2/21	250 / [1112]	NYLON 6/6	UV BLACK	1.50 / [38]	8.00 / [203]	22 / [559]	0.5 / [13]	32 / 0	-40 / -40	185 / 85	25		
10023633	CT250200RQ	RELEASABLE	TYPE 2/21	250 / [1112]	NYLON 6/6	NATURAL	1.50 / [38]	2.25 / [57]	9 / [229]	0.5 / [13]	32 / 0	-40 / -40	185 / 85	25		
10023634	CT250200RQ0	RELEASABLE	TYPE 2/21	250 / [1112]	NYLON 6/6	UV BLACK	1.50 / [38]	2.25 / [57]	9 / [229]	0.5 / [13]	32 / 0	-40 / -40	185 / 85	25		
10023636	CT250500RQ0	RELEASABLE	TYPE 2/21	250 / [1112]	NYLON 6/6	UV BLACK	1.50 / [38]	6.00 / [152]	22 / [559]	0.5 / [13]	32 / 0	-40 / -40	185 / 85	25		
10023637	CT250600RQ	RELEASABLE	TYPE 2/21	250 / [1112]	NYLON 6/6	NATURAL	1.50 / [38]	6.00 / [152]	22 / [559]	0.5 / [13]	32 / 0	-40 / -40	185 / 85	25		
10023638	CT250600RQ0	RELEASABLE	TYPE 2/21	250 / [1112]	NYLON 6/6	UV BLACK	1.50 / [38]	6.00 / [152]	22 / [559]	0.5 / [13]	32 / 0	-40 / -40	185 / 85	25		
10023639	CT250800RQ	RELEASABLE	TYPE 2/21	250 / [1112]	NYLON 6/6	NATURAL	1.50 / [38]	8.00 / [203]	29 / [737]	0.5 / [13]	32 / 0	-40 / -40	185 / 85	25		
10023640	CT250800RQ0	RELEASABLE	TYPE 2/21	250 / [1112]	NYLON 6/6	UV BLACK	1.50 / [38]	8.00 / [203]	29 / [737]	0.5 / [13]	32 / 0	-40 / -40	185 / 85	25		
10023641	CT2501000RQ	RELEASABLE	TYPE 2/21	250 / [1112]	NYLON 6/6	NATURAL	1.50 / [38]	10.00 / [254]	34 / [864]	0.5 / [13]	32 / 0	-40 / -40	185 / 85	25	38	10
10023635	CT250500RQ	RELEASABLE	TYPE 2/21	250 / [1112]	NYLON 6/6	NATURAL	1.50 / [38]	6.00 / [152]	23 / [589]	0.5 / [13]	32 / 0	-40 / -40	185 / 85	25		

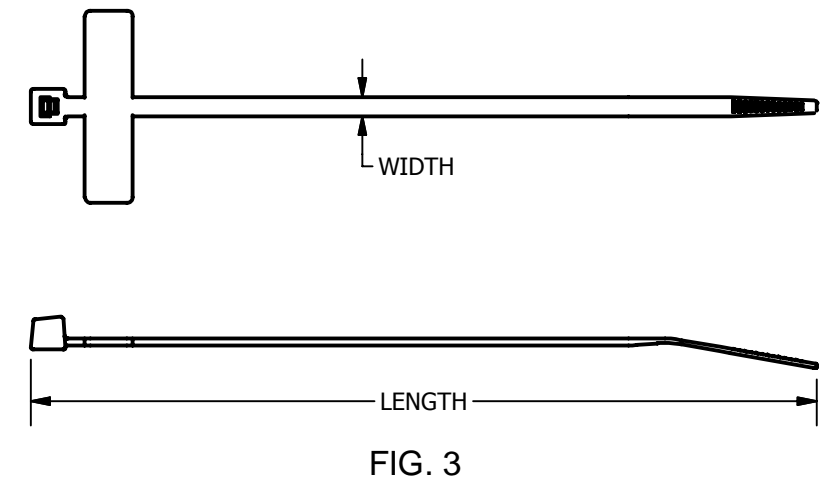
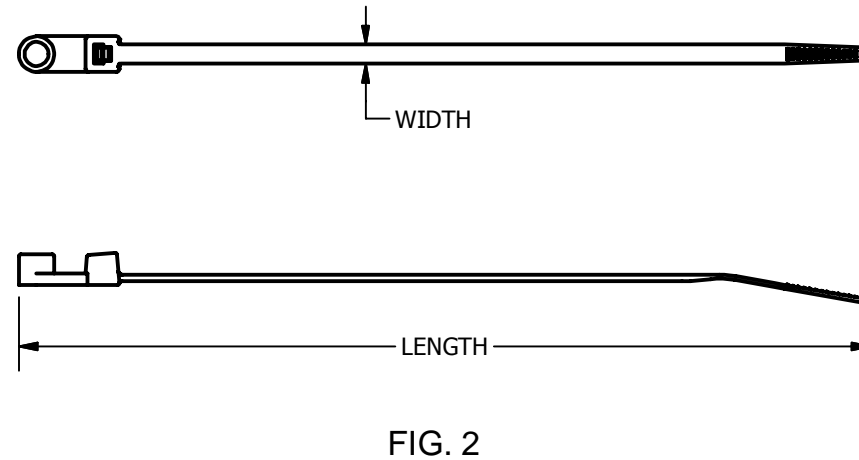
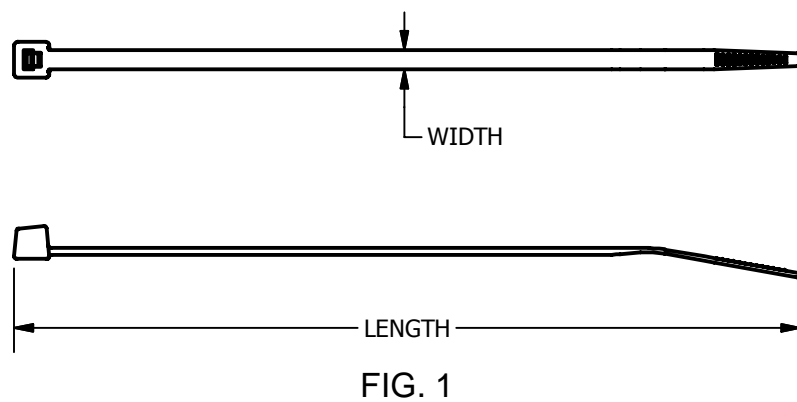

NOTES:

1. DIMENSIONS IN BRACKETS [] ARE IN MILLIMETERS ROUNDED OFF TO THE NEAREST MILLIMETER, UNLESS OTHERWISE SPECIFIED AND ARE FOR REFERENCE ONLY.
2. COLOR "UV BLACK "TIES ARE MANUFACTURED USING NYLON 6/6 WITH A 2% CARBON BLACK ADDITIVE FOR A UV STABILIZER WHICH IS THE SAME AS PA66UV.
3. OPTIMUM STORAGE CONDITIONS FOR NYLON 6/6 CABLE TIES IS 70°F / 21°C AT 50% RELATIVE HUMIDITY. CABLE TIES SHOULD BE STORED IN THE MANUFACTURE'S ORIGINAL PACKAGING UNTIL READY FOR USE.

4-NYLON 6/6 IS THE SAME AS PA66 (POLYAMIDE- PA66 IS THE ENGINEERING TERM FOR NYLON 6/6).

TO ORDER BURNDY PRODUCTS CALL		UNIRAP™	
1-800-346-4175 (LONDONDERRY, NH)		ITEM NO: SEE TABLE	
CANADA:		CAT. NO: SEE TABLE	
1-800-361-6975 (QUEBEC)		DRAWN BY: A. MONTMINY 04/26/2013	
1-800-387-6487 (ALL OTHER PROVINCES)		CHECKER:	
FOR PRODUCT INFO: http://www.burndy.com		DSN APRVL: A. MONTMINY 01/06/2014	
		MFG APRVL: P. KEENAN 12/27/2013	
		QA APRVL: C. KOWALCZYK 01/06/2014	
		MKT APRVL: R. CAVANAUGH 01/06/2014	
		PROJ #:	
		SIZE:	
		DRAWING NO:	
		REV:	
		50034347	
		D	
		SHEET 1 OF 1	