

REV	DATE	DESCRIPTION	ECO	BY	CHK.
A	11/05/2013	NEW DRAWING CREATED	33821	PB	VK

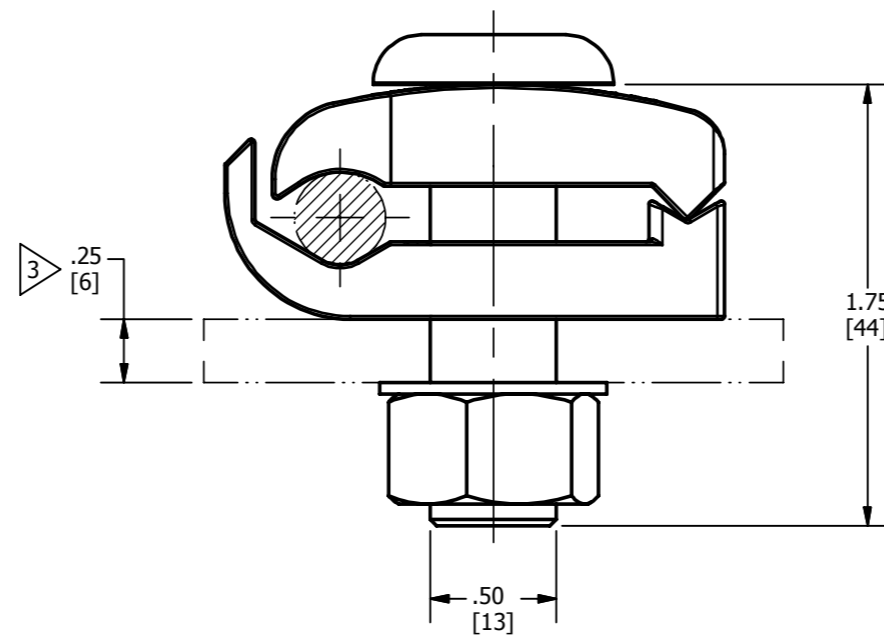
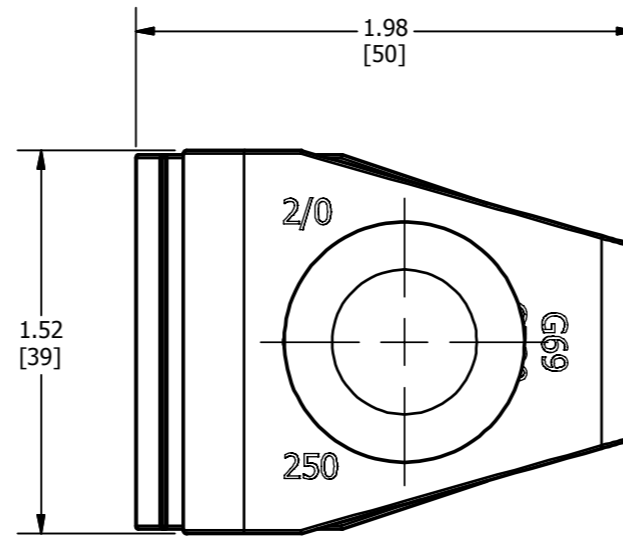

**NOTES:**

- MATERIAL:**  
 BODY : CAST COPPER ALLOY  
 HARDWARE : SILICON BRONZE
- DIMENSIONS IN BRACKETS [ ] ARE IN MILLIMETERS ROUNDED OFF TO THE NEAREST MILLIMETER, UNLESS OTHERWISE SPECIFIED AND ARE FOR REFERENCE ONLY.
- STANDARD BASIC CATALOG NUMBER AND BOLT LENGTH IS BASED ON A MAXIMUM BAR THICKNESS OF 1/4".  
 ADD - T4 SUFFIX FOR USE ON A BAR WITH A 1/2" MAXIMUM THICKNESS.  
 ADD - T8 SUFFIX FOR USE ON A BAR WITH A 1" MAXIMUM THICKNESS.
- ACCOMMODATES:**  
 AWG 2/0 SOLID (.365 DIA.) TO 250 KCMIL (.575 DIA.) STRANDED COPPER.  
 70MM<sup>2</sup> (10.9 MM) TO 120MM<sup>2</sup> (14.4MM) CLASS 2 STRANDED COPPER.
- RECOMMENDED TIGHTENING TORQUE 480 INCH POUNDS. TO GREATLY REDUCE OR EXCEED THE RECOMMENDED TORQUE CAN ADVERSELY AFFECT THE PERFORMANCE ON THE CONNECTOR.

TO ORDER BURNDY® PRODUCTS CALL		GROUNDING CONNECTOR													
UNITED STATES 1-800-346-4175 (LONDONDERRY, NH)		ITEM NO: 26418L													
CANADA: 1-800-361-6975 (QUEBEC) 1-800-387-6487 (ALL OTHER PROVINCES)		CAT. NO: GB29G69													
FOR PRODUCT INFO: <a href="http://www.burndy.com">http://www.burndy.com</a>		<table border="1"> <tr> <td>DRAWN BY: PARTHIBAN B</td> <td>11/5/2013</td> </tr> <tr> <td>CHECKER: L TROMBLEY</td> <td>11/12/2013</td> </tr> <tr> <td>DSN APRVL: L TROMBLEY</td> <td>11/12/2013</td> </tr> <tr> <td>MFG APRVL: T WAWRZYNIAK</td> <td>11/12/2013</td> </tr> <tr> <td>QA APRVL: J HILLMAN</td> <td>11/11/2013</td> </tr> <tr> <td>MKT APRVL: P THERRIEN</td> <td>11/5/2013</td> </tr> </table>		DRAWN BY: PARTHIBAN B	11/5/2013	CHECKER: L TROMBLEY	11/12/2013	DSN APRVL: L TROMBLEY	11/12/2013	MFG APRVL: T WAWRZYNIAK	11/12/2013	QA APRVL: J HILLMAN	11/11/2013	MKT APRVL: P THERRIEN	11/5/2013
DRAWN BY: PARTHIBAN B	11/5/2013														
CHECKER: L TROMBLEY	11/12/2013														
DSN APRVL: L TROMBLEY	11/12/2013														
MFG APRVL: T WAWRZYNIAK	11/12/2013														
QA APRVL: J HILLMAN	11/11/2013														
MKT APRVL: P THERRIEN	11/5/2013														
PROJ FAM: --		DRAWING NO													
PROJECT #: --		50034696													
DOCUMENT TYPE: SALES		SIZE													
REL LEVEL: Released		B													
		REV													
		A													
		SHEET 1 OF 1													

