

CATALOG NO.	CONDUCTOR RANGE				INSTALLATION TOOLING (#CRIMPS)							
	ACSR		ALUM.		TOOL INDEX NO.	HYTOOL™ WITH NO. OF CRIMPS		HYPRESS™ & DIE SET WITH NO. OF CRIMPS				
	AWG kcmil	STR.	AWG kcmil	STR.		MD6 (DIE SET)		Y35/Y750		Y45L	Y60	
YCA25R2N15	1/0 (.398)	6-1	1/0 (.373)	7,19	BG 243	W-BG W243	8 4	U243	2	--	L243	1

REV	DATE	DESCRIPTION	ECO	BY	CH'K.
A	12/26/2013	DRAWING RELEASED	34210	YM	MB

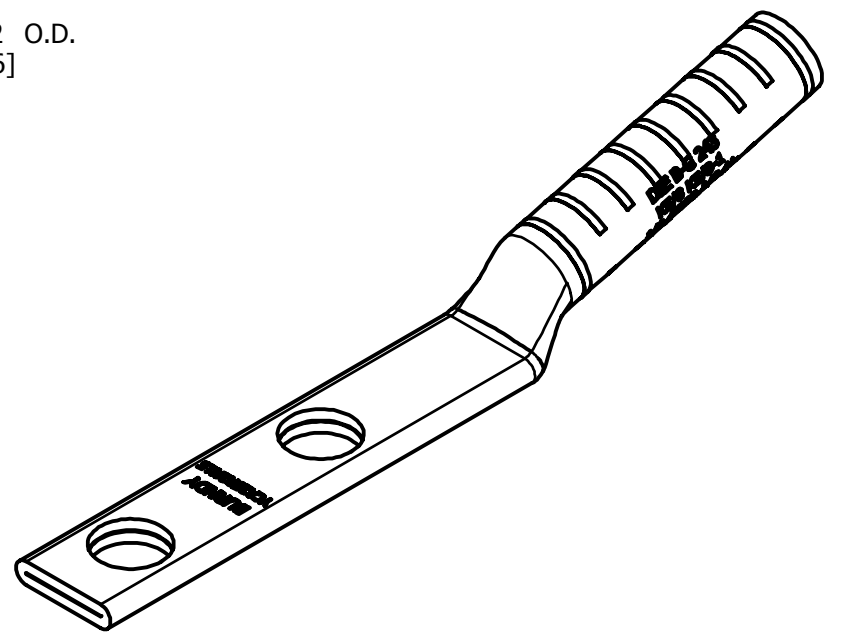
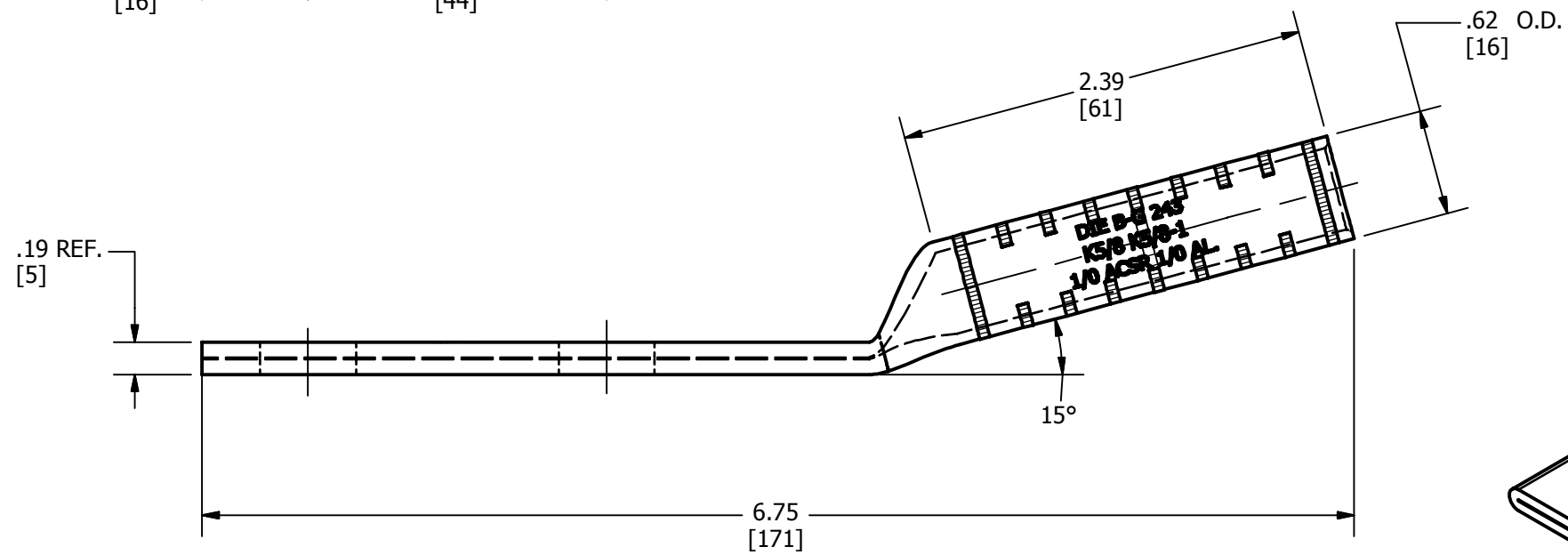
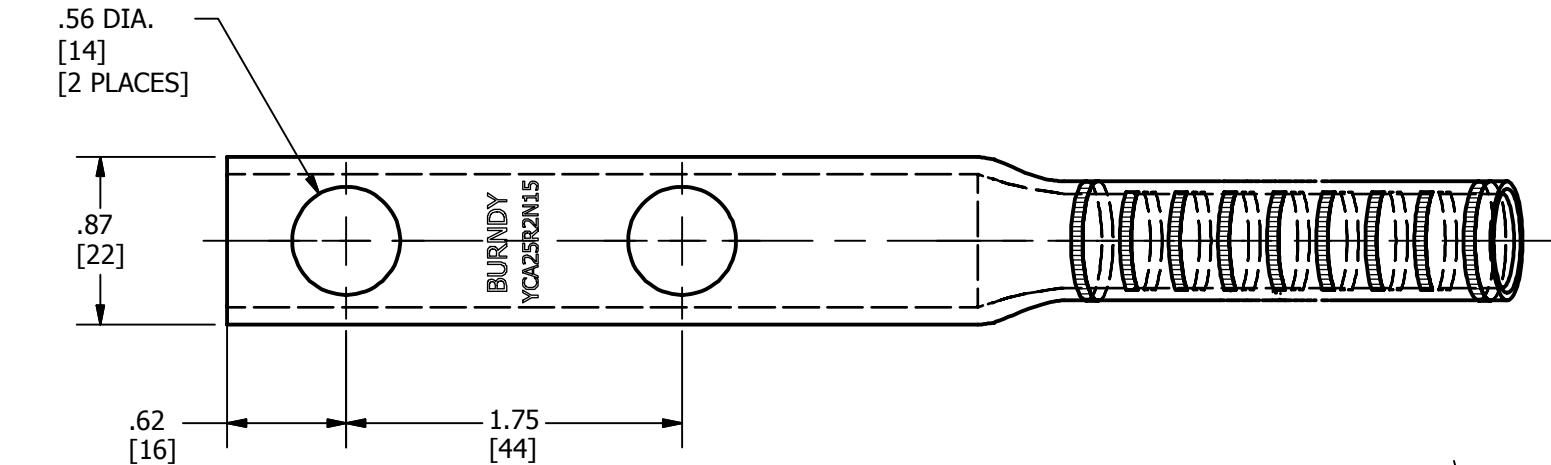

- NOTES:
- MATERIAL: ALUMINUM.
  - DIMENSIONS IN BRACKETS [ ] ARE IN MILLIMETERS ROUNDED OFF TO THE NEAREST MILLIMETER, UNLESS OTHERWISE NOTED, AND ARE FOR REFERENCE ONLY.

TO ORDER BURNDY® PRODUCTS CALL		HYLUG™	
UNITED STATES 1-800-346-4175 (LONDONDERRY, NH)		ITEM NO: 50032197	
CANADA: 1-800-361-6975 (QUEBEC) 1-800-387-6487 (ALL OTHER PROVINCES)		CAT. NO: YCA25R2N15	
FOR PRODUCT INFO: <a href="http://www.burndy.com">http://www.burndy.com</a>		DRAWN BY: MANIMEKALA 11/08/2013	
		CHECKER: MANIKANDAN 11/08/2013	
		DSN APRVL: ZAHLMAN 12/06/2013	
		MFG APRVL: JOE 12/07/2013	
		QA APRVL: WATTS 12/06/2013	
		MKT APRVL: HALL 12/06/2013	
PROD FAM: --	DRAWING NO	REV	
PROJECT #: --	SIZE	50035099	A
DOCUMENT TYPE: SALES	B	SHEET 1 OF 1	
REL LEVEL: Released			