

CATALOG NO.	CONDUCTOR			INSTALLATION TOOLING							WIRE STRIP LENGTH	
				DIE INDEX	COLOR CODE	MECHANICAL RATCHET		HYDRAULIC TOOLS				DIELESS (# CRIMPS)
	AWG	MM ²	STUD HOLE SIZE			MD6, OUR840, MD7-34R	PAT60018V, Y500CTHS	Y750, Y35, Y39, PAT750	Y46 PAT46	Y45		
YAV25L2NT14FX90	1/0 AWG 1/0 WELD 275/24	50	1/4" [M6]	12 OR 348	PINK	W 25RT X25RT W 25VT (2)	W 25RT X25RT W 25VT (2)	U25RT (1)	U25RT (1)	U25RT (1)	MY29-11 (1) Y81KFT(1) Y81KFTMBH(1) PAT81KFT-18V(1) Y4PC834 (1) PAT4PC834-18V (1)	11/16"

REV	DATE	DESCRIPTION	ECO	BY	C'H'K.
A	05/26/2014	DRAWING RELEASED	34930	DD	MA

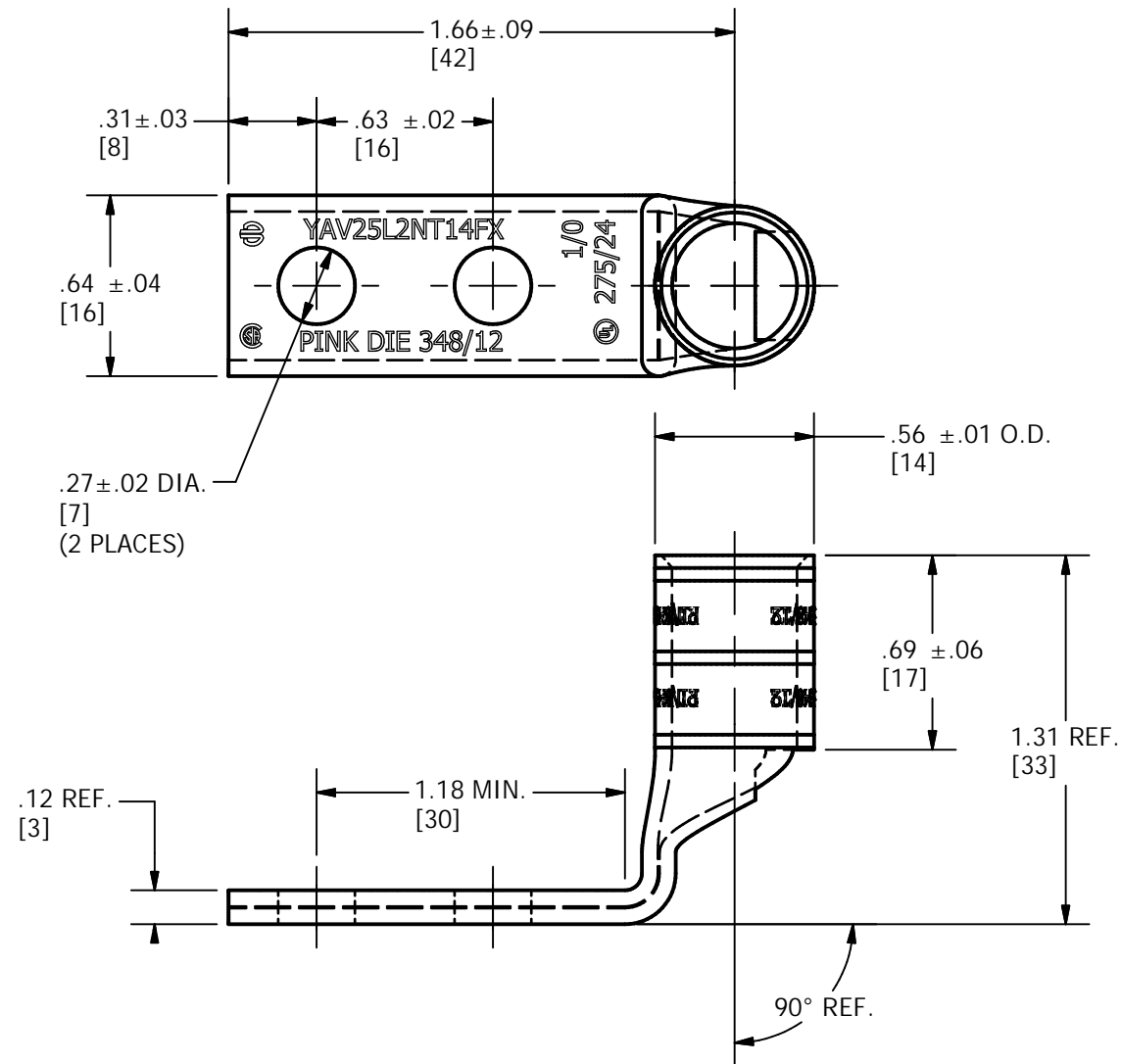

NOTES:

1. MATERIAL: COPPER TUBING
2. FINISH: TIN PLATED
3. DIMENSIONS IN BRACKETS [] ARE IN MILLIMETERS ROUNDED OFF TO THE NEAREST MILLIMETER, UNLESS OTHERWISE SPECIFIED AND ARE FOR REFERENCE ONLY.
4. USE CAT. NO. PT6515 ADAPTER (ORDERED SEPARATELY) WHEN USING 'U' DIES IN Y45 TOOL.
5. USE CAT. NO. PUADP-1 ADAPTER (ORDERED SEPARATELY) WHEN USING 'U' DIES IN Y46 TOOL.

TO ORDER BURNDY® PRODUCTS CALL		HYLUG™ (NARROW TONGUE)	
UNITED STATES 1-800-346-4175 (LONDONDERRY, NH)		ITEM NO: 50032211	
CANADA: 1-800-361-6975 (QUEBEC) 1-800-387-6487 (ALL OTHER PROVINCES)		CAT. NO: YAV25L2NT14FX90	
FOR PRODUCT INFO: http://www.burndy.com		DRAWN BY: GNATH 11/13/2013	
		CHECKER: J.MICHAUD 7/2/2014	
		DSN APRVL: J.MICHAUD 7/2/2014	
		MFG APRVL: B.WHITE 7/2/2014	
		QA APRVL: T.WATTS 7/2/2014	
		MKT APRVL: K.BOUTIN 7/2/2014	
		PROD FAM: --	
		DRAWING NO	
		50035189	
		REV	
		A	
		SHEET 1 OF 1	