

REV	DATE	DESCRIPTION	ECO	BY	C'HK.
A	05/13/2014	DRAWING RELEASED	36057	DD	MA

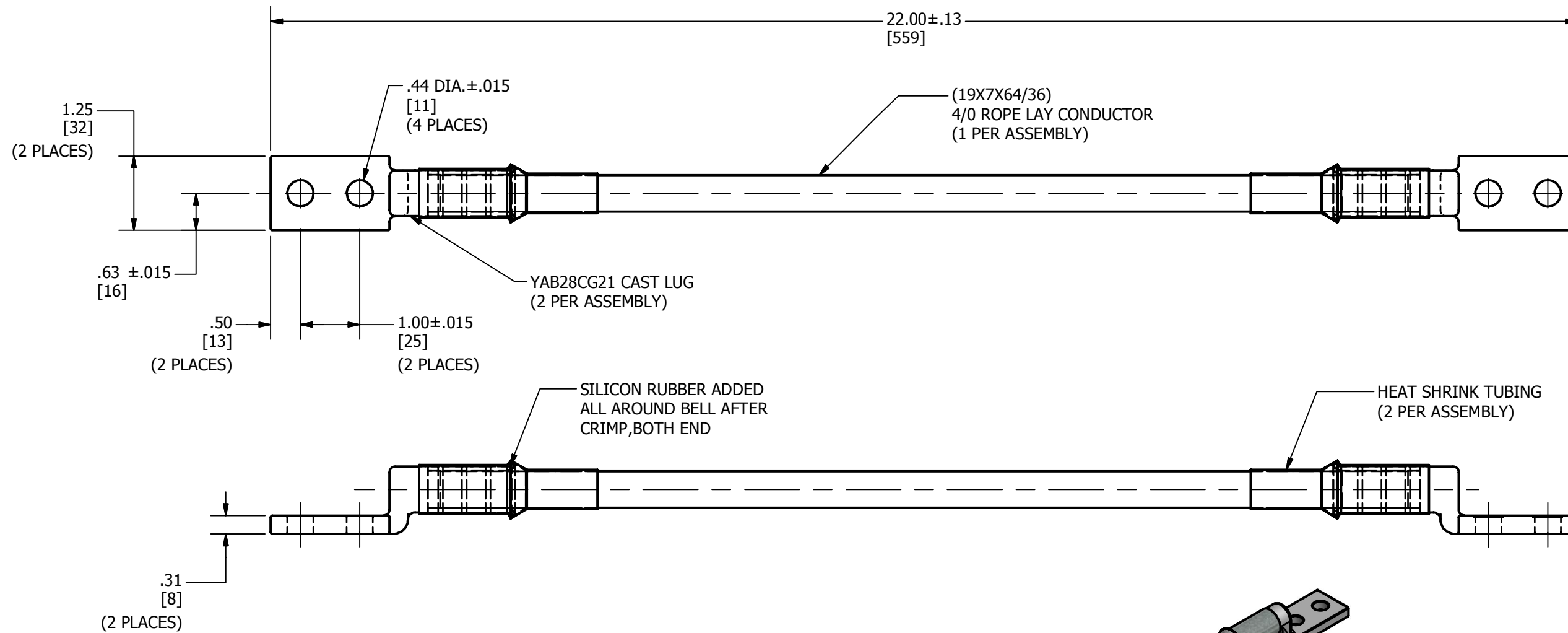

NOTES:

1. FINISH: TIN PLATED.
2. DIMENSIONS IN BRACKETS [] ARE IN MILLIMETERS ROUNDED OFF TO THE NEAREST MILLIMETER UNLESS OTHERWISE SPECIFIED AND ARE FOR REFERENCE ONLY.
3. APPROXIMATE AMP RATING: 335A. THIS RATING MAY VARY WITH AMBIENT CONDITIONS, ORIENTATION OF THE BRAID, AND OTHER SERVICE FACTORS.
4. APPROXIMATE WEIGHT: .288 LBS.

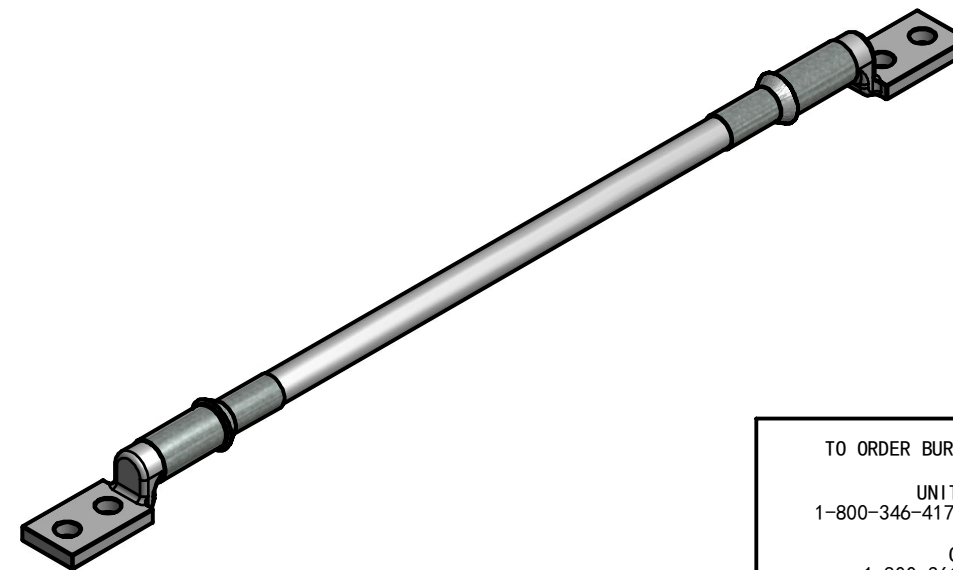

TO ORDER BURNDY® PRODUCTS CALL		CUSTOM JUMPER	
UNITED STATES		ITEM NO: 50041107	
1-800-346-4175 (LONDONDERRY, NH)		CAT. NO: CY4/0L22G5TN	
CANADA:		DRAWN BY: GANTH 4/2/2014	
1-800-361-6975 (QUEBEC)		CHECKER: B. MANIKANDAN 4/2/2014	
1-800-387-6487 (ALL OTHER PROVINCES)		DSN APRVL: L. TROMBLEY 5/8/2014	
FOR PRODUCT INFO: http://www.burndy.com		MFG APRVL: M. STEVENS 5/8/2014	
		QA APRVL: C. LINDQUIST 5/13/2014	
		MKT APRVL: K. ROBICHEAU 5/8/2014	
PROD FAM: --	DRAWING NO	REV	
PROJECT #: --	SIZE	50041108	A
DOCUMENT TYPE: SALES	B	SHEET 1 OF 1	
REL LEVEL: Released			