

CATALOG NUMBER	CONDUCTOR			STUD SIZE	INSTALLATION TOOLING							WIRE STRIP LENGTH
	AWG	METRIC (mm ²) CLASS 2	NAVY CABLE SIZE		DIE INDEX	COLOR	DIELESS TOOLS & NO. OF CRIMPS	TOOLS, DIE NO.'S & (NO. OF CRIMPS)				
								MD6, OUR840, MD7-34R	BCT500HS, Y500CTHS	Y35, Y39, Y750, PAT750, Y46		
YA1C2NT14	#1	50	75	1/4"	11 OR 375	GREEN	Y1MRTC (4) MY29 - 3 (2) MY29 - 11 (2) MRC840 (2) Y644HSXT (1) Y81KFT (2) Y81KFTMBH (2) PAT81KFT - 18V (2)	W1CVT (2) W1CRT-1 (2) X1CRT-1 (2)	W1CVT (2) W1CRT-1 (2) X1CRT-1 (2)	U1CRT-1 (2) U4CABT (2)	1-7/16"	

REV	DATE	DESCRIPTION	ECO	BY	CHK.
A	07/18/2014	DRAWING RELEASED	36232	RK	MB

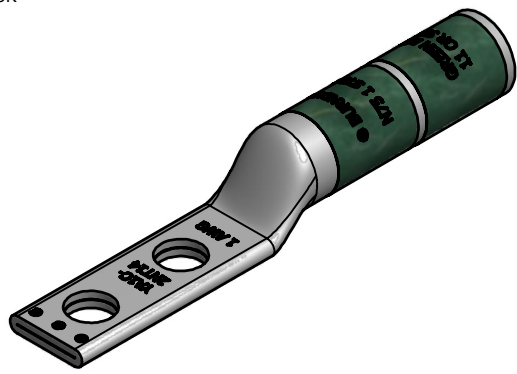
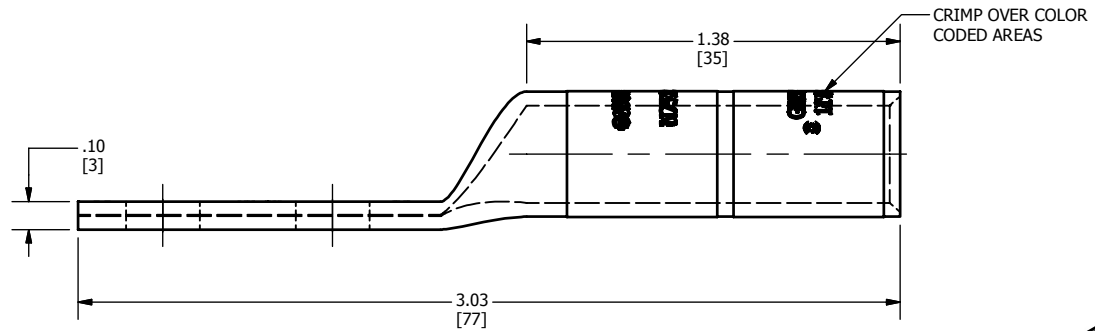
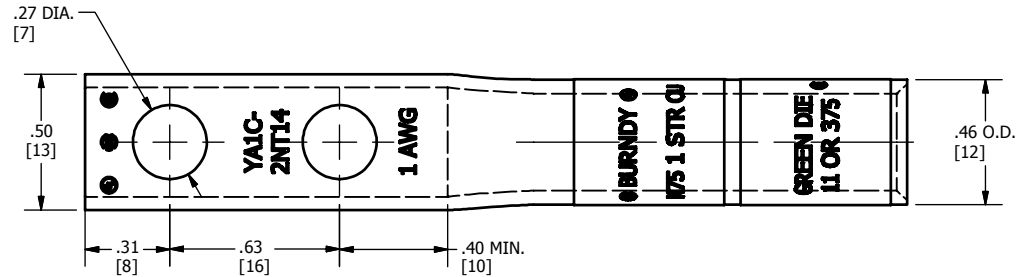

NOTES:

1. MATERIAL: COPPER TUBING.
2. FINISH: TIN PLATED.
3. CAT NO. PUADP-1 ADAPTOR IS REQUIRED TO USE 'U' DIES IN Y46 SERIES TOOLS.
4. DIMENSIONS IN BRACKETS [] ARE IN MILLIMETERS ROUNDED OFF TO THE NEAREST MILLIMETER, UNLESS OTHERWISE SPECIFIED AND ARE FOR REFERENCE ONLY.
5. "X" DIE SETS ALSO WORK IN THE BCT500, Y500CT & PAT600 SERIES TOOLS.
6. UL LISTED AND CSA CERTIFIED WIRE CONNECTORS.

TO ORDER BURNDY® PRODUCTS CALL		HYLUG™	
UNITED STATES 1-800-346-4175 (LONDONDERRY, NH)		ITEM NO: 50043672	CAT. NO: YA1C2NT14
CANADA: 1-800-361-6975 (QUEBEC) 1-800-387-6487 (ALL OTHER PROVINCES)		DRAWN BY: rkonathale 07/09/2014	CHECKER: --
FOR PRODUCT INFO: http://www.burndy.com		DSN APRVL: J MICHAUD 08/19/2014	MFG APRVL: --
		QA APRVL: C ACKERMAN 08/20/2014	MKT APRVL: K BOUTIN 08/19/2014
		PROJ FIRM: --	PROJECT #: --
		SIZE	DRAWING NO
		REL LEVEL: Released	50046198
			SHEET 1 OF 1
			REV A