

CATALOG NUMBER	CONDUCTOR			STUD SIZE	INSTALLATION TOOLING				WIRE STRIP LENGTH		
	AWG	METRIC (mm <sup>2</sup> ) CLASS 2	NAVY CABLE SIZE		DIE INDEX	COLOR	DIELESS TOOLS & NO. OF CRIMPS	TOOLS, DIE NO.'S & (NO. OF CRIMPS)			
								MD6, OUR840, MD7-34R		BCT500HS, Y500CTHS	Y35, Y39, Y750, PAT750, Y46
YA262NT38	2/0	70	125	3/8"	13	BLACK	MY29 - 3 (2) MY29 - 11 (2) MRC840 (4) Y644HSXT (1) Y81KFT (2) Y81KFTMBH (2) PAT81KFT - 18V (2)	W26VT (4) W26RT (4) X26RT (4)	W26VT (4) W26RT (4) X26RT (4)	U26RT (2)	1-9/16"

REV	DATE	DESCRIPTION	ECO	BY	C'H'K.
A	07/22/2014	DRAWING RELEASED	36232	RK	MB

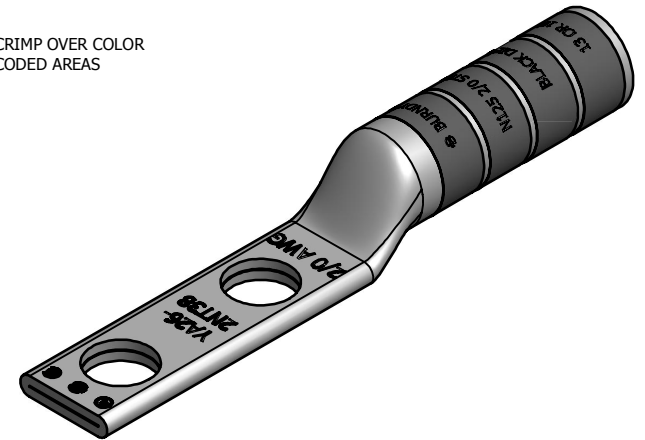
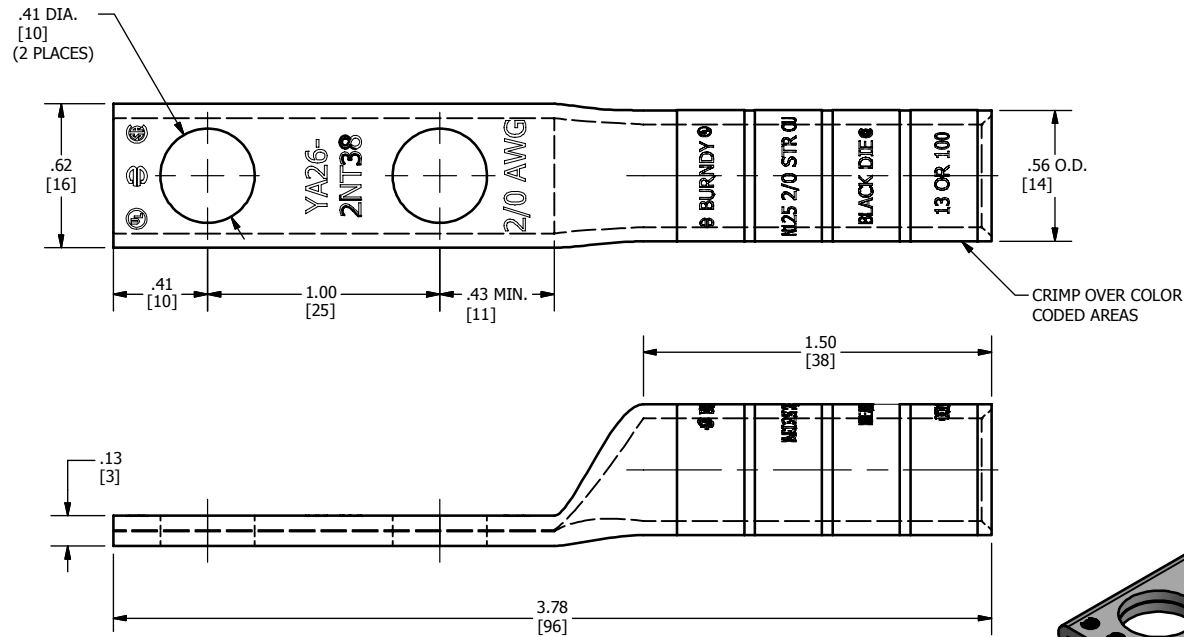

**NOTES:**

1. MATERIAL: COPPER TUBING.
2. FINISH: TIN PLATED.

3 CAT NO. PUADP-1 ADAPTOR IS REQUIRED TO USE 'U' DIES IN Y46 SERIES TOOLS.

4. DIMENSIONS IN BRACKETS [ ] ARE IN MILLIMETERS ROUNDED OFF TO THE NEAREST MILLIMETER, UNLESS OTHERWISE SPECIFIED AND ARE FOR REFERENCE ONLY.

5 "X" DIE SETS ALSO WORK IN THE BCT500, Y500CT & PAT600 SERIES TOOLS.

6. UL LISTED AND CSA CERTIFIED WIRE CONNECTORS.

TO ORDER BURNDY® PRODUCTS CALL		HYLUG™	
UNITED STATES 1-800-346-4175 (LONDONDERRY, NH)		ITEM NO: 50043681	
CANADA: 1-800-361-6975 (QUEBEC) 1-800-387-6487 (ALL OTHER PROVINCES)		CAT. NO: YA262NT38	
FOR PRODUCT INFO: <a href="http://www.burndy.com">http://www.burndy.com</a>		DRAWN BY: rkonathala 07/09/2014	
		CHECKER: --	
		DSN APRVL: J MICHAUD 08/19/2014	
		MFG APRVL: --	
		QA APRVL: C ACKERMAN 08/20/2014	
		MKT APRVL: K BOUTIN 08/19/2014	
		PROJ FMT: --	
		PROJECT #: --	
		DOCUMENT TYPE: SALES	
		REL LEVEL: Released	
		DRAWING NO: 50046216	
		SIZE: B	
		REV: A	
		SHEET 1 OF 1	