

CATALOG NUMBER	CONDUCTOR			STUD SIZE	INSTALLATION TOOLING						WIRE STRIP LENGTH
	AWG	METRIC (mm ²) CLASS 2	NAVY CABLE SIZE		DIE INDEX	COLOR	DIELESS TOOLS & NO. OF CRIMPS	TOOLS, DIE NO.'S & (NO. OF CRIMPS)			
								MD6, OUR840, MD7-34R	BCT500HS, Y500CTHS	Y35, Y39, Y750, PAT750, Y46	
YA342NNT	500 kcmil	240	---	1/2"	20 OR 299	BROWN	Y644HSXT (1) Y81KFT (4) Y81KFTMBH (4) PAT81KFT - 18V (4)	W34VT (4)	W34VT (4) W34RT (4)	U34RT (4) U31ART (2)	2-5/16"

REV	DATE	DESCRIPTION	ECO	BY	C'HK.
A	07/23/2014	DRAWING RELEASED	36232	RK	MB

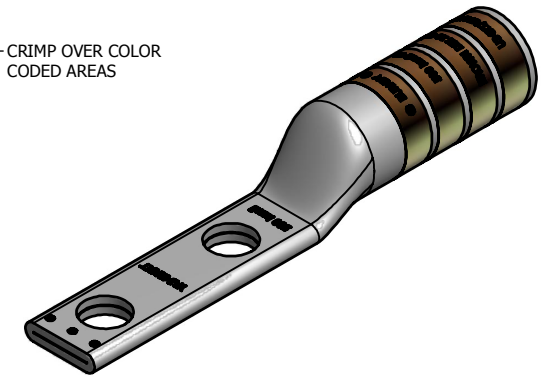
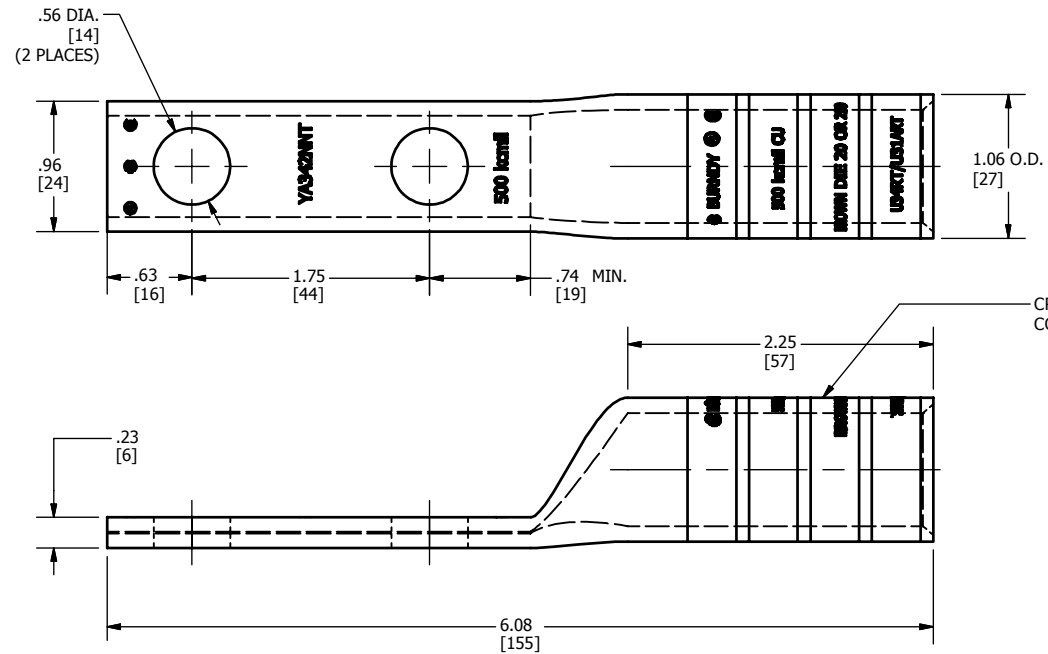

NOTES:

1. MATERIAL: COPPER TUBING.
2. FINISH: TIN PLATED.
3. CAT NO. PUADP-1 ADAPTOR IS REQUIRED TO USE 'U' DIES IN Y46 SERIES TOOLS.
4. DIMENSIONS IN BRACKETS [] ARE IN MILLIMETERS ROUNDED OFF TO THE NEAREST MILLIMETER, UNLESS OTHERWISE SPECIFIED AND ARE FOR REFERENCE ONLY.
5. "X" DIE SETS ALSO WORK IN THE BCT500, Y500CT & PAT600 SERIES TOOLS.
6. UL LISTED AND CSA CERTIFIED WIRE CONNECTORS.

TO ORDER BURNDY® PRODUCTS CALL		HYLUG™	
UNITED STATES		ITEM NO: 50043702	
1-800-346-4175 (LONDONDERRY, NH)		CAT. NO: YA342NNT	
CANADA:		DRAWN BY: rkonathale 05/26/2014	
1-800-361-6975 (QUEBEC)		CHECKER: --	
1-800-387-6487 (ALL OTHER PROVINCES)		DSN APRVL: J MICHAUD 08/19/2014	
FOR PRODUCT INFO: http://www.burndy.com		MFG APRVL: --	
		QA APRVL: C ACKERMAN 08/20/2014	
		MKT APRVL: K BOUTIN 08/19/2014	
		PROD FARM: --	
		PROJECT #: --	
		DRAWING NO	
		50046227	
		REV	
		A	
		SHEET 1 OF 1	
		REL LEVEL: Released	