

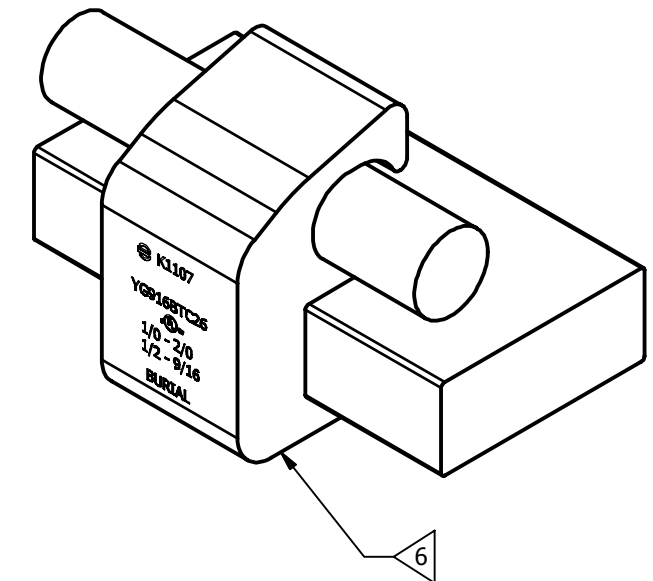

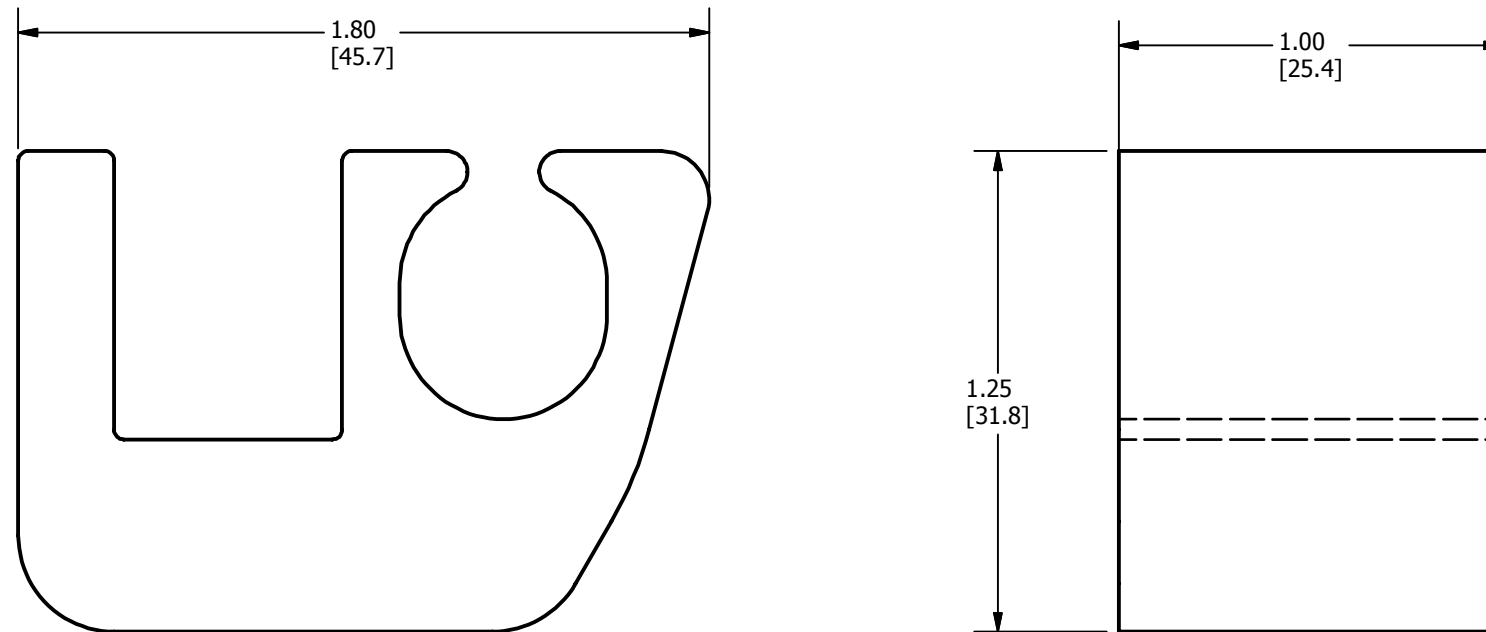



CONDUCTOR ACCOMMODATION	
RUN	TAP
1/2" [12.7] - 9/16" [14.29] THICK STEEL AND COPPER BUS BAR	1/0 AWG STR. TO 2/0 AWG STR COPPER



REV	DATE	DESCRIPTION	ECO	BY	C'H'K.
A	9/22/2014	DRAWING RELEASE	37900	RM	RG



 K1107
 YG916BTC26

 1/0 - 2/0
 1/2 - 9/16
 BURIAL

TYPICAL STAMPING

- NOTES:
- MATERIAL: PURE WROUGHT COPPER ALLOY.
 - CONDUCTOR AND BUSBAR GROOVES PREFILLED WITH PENETROX™ S4.
 - INSTALLED WITH ONE CRIMP USING THE K1107 WITH THE PAT750K  HYPRESS™ SERIES HYDRAULIC TOOL.
 - DIMENSIONS IN BRACKETS [] ARE IN MILLIMETERS ROUNDED TO THE NEAREST MILLIMETER, UNLESS OTHERWISE SPECIFIED, AND ARE FOR REFERENCE ONLY.
 -  TO ORDER TIN PLATED ADD SUFFIX "TP" TO THE END OF THE CATALOG NUMBER. EXAMPLE: YG916BTC28TP
 -  IT IS RECOMMENDED TO PRE-CRIMP USING THE K1107 DIE FOR ADDITIONAL HOLDING STRENGTH.

TO ORDER BURNDY® PRODUCTS CALL		BUSBAR CONNECTOR													
UNITED STATES 1-800-346-4175 (LONDONDERRY, NH)		ITEM NO: 50047809													
CANADA: 1-800-361-6975 (QUEBEC) 1-800-387-6487 (ALL OTHER PROVINCES)		CAT. NO: YG916BTC26 													
FOR PRODUCT INFO: http://www.burndy.com		<table border="1"> <tr> <td>DRAWN BY: THIRU</td> <td>8/7/2014</td> </tr> <tr> <td>CHECKER: T. LOGAN</td> <td>10/1/2014</td> </tr> <tr> <td>DSN APRVL: T. LOGAN</td> <td>10/1/2014</td> </tr> <tr> <td>MFG APRVL: H. JOE</td> <td>10/2/2014</td> </tr> <tr> <td>QA APRVL: W. TIMOTHY</td> <td>10/17/2014</td> </tr> <tr> <td>MKT APRVL: R. KATHLEEN</td> <td>10/2/2014</td> </tr> </table>		DRAWN BY: THIRU	8/7/2014	CHECKER: T. LOGAN	10/1/2014	DSN APRVL: T. LOGAN	10/1/2014	MFG APRVL: H. JOE	10/2/2014	QA APRVL: W. TIMOTHY	10/17/2014	MKT APRVL: R. KATHLEEN	10/2/2014
DRAWN BY: THIRU	8/7/2014														
CHECKER: T. LOGAN	10/1/2014														
DSN APRVL: T. LOGAN	10/1/2014														
MFG APRVL: H. JOE	10/2/2014														
QA APRVL: W. TIMOTHY	10/17/2014														
MKT APRVL: R. KATHLEEN	10/2/2014														
<table border="1"> <tr> <td>PROJ #:</td> <td>---</td> <td>SIZE:</td> <td>B</td> </tr> <tr> <td>DOC TYPE:</td> <td>SALES</td> <td>DRAWING NO:</td> <td>50047810</td> </tr> <tr> <td>REL LEVEL:</td> <td>Released</td> <td>REV:</td> <td>A</td> </tr> </table>		PROJ #:	---	SIZE:	B	DOC TYPE:	SALES	DRAWING NO:	50047810	REL LEVEL:	Released	REV:	A	 SHEET 1 OF 1	
PROJ #:	---	SIZE:	B												
DOC TYPE:	SALES	DRAWING NO:	50047810												
REL LEVEL:	Released	REV:	A												