

| CATALOG NUMBER | ACCOMMODATES ALUMINUM | INSTALLATION TOOLING (# CRIMPS) | | | | DIELESS (# CRIMPS) | WIRE STRIP LENGTH |
|----------------|--|---------------------------------|-----------|------------------|-----------|------------------------|-------------------|
| | | DIE INFORMATION | | HYDRAULIC | | | |
| | | COLOR CODE | DIE INDEX | Y39,Y750, PAT750 | Y46 PAT46 | | |
| AYP900 | 900 kcmil AL | GRAY | 303 | U42ART (4) | | Y644 (2) PAT644 (2) | 2-3/8" |
| AYPO900 | 900 - 600 kcmil AL OR 600 kcmil CU | ---- | ---- | ---- | | OVERLAP 2 CRIMPS | |

| REV | DATE | DESCRIPTION | ECO | BY | C'H.K. |
|-----|-----------|------------------------|-------|----|--------|
| C | 12/7/2015 | ADDED THE PIN DIAMETER | 42359 | RM | RG |

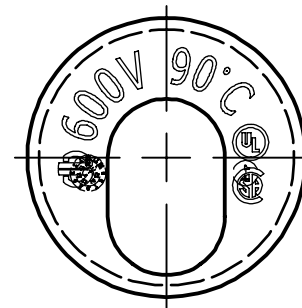
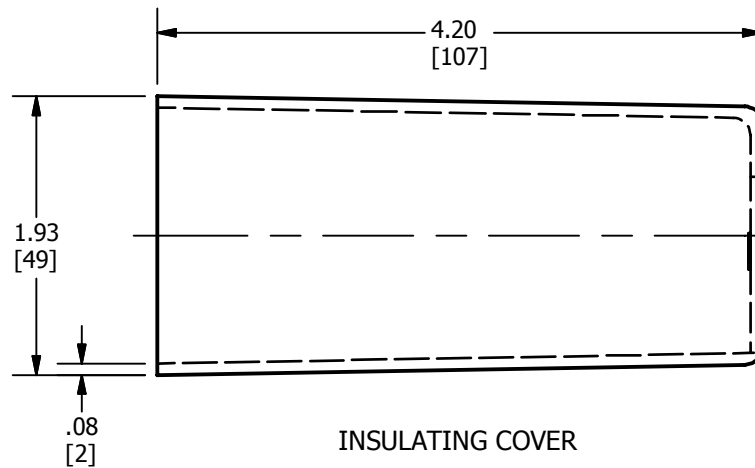
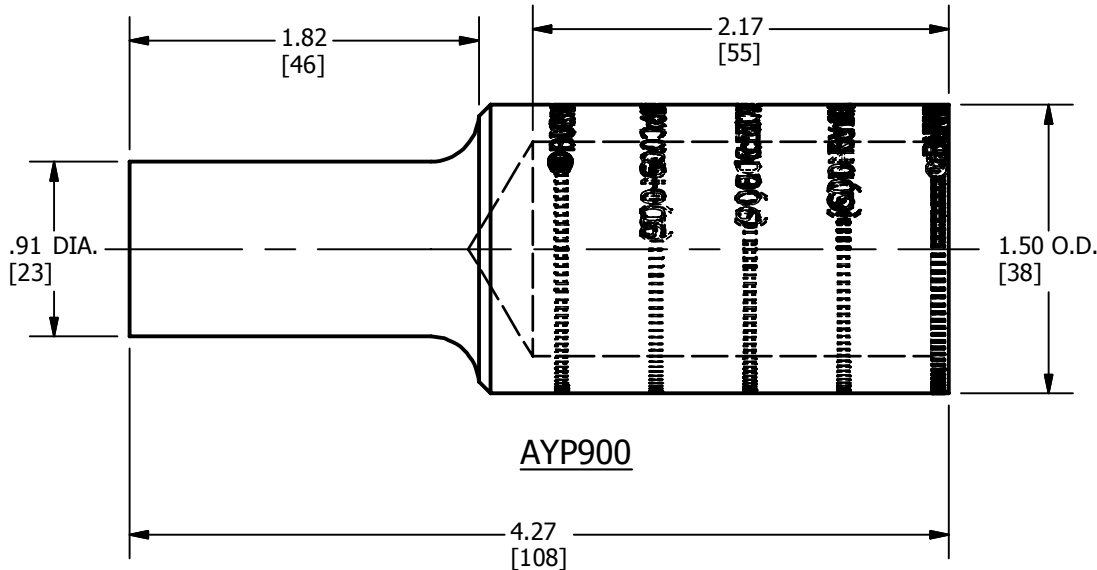
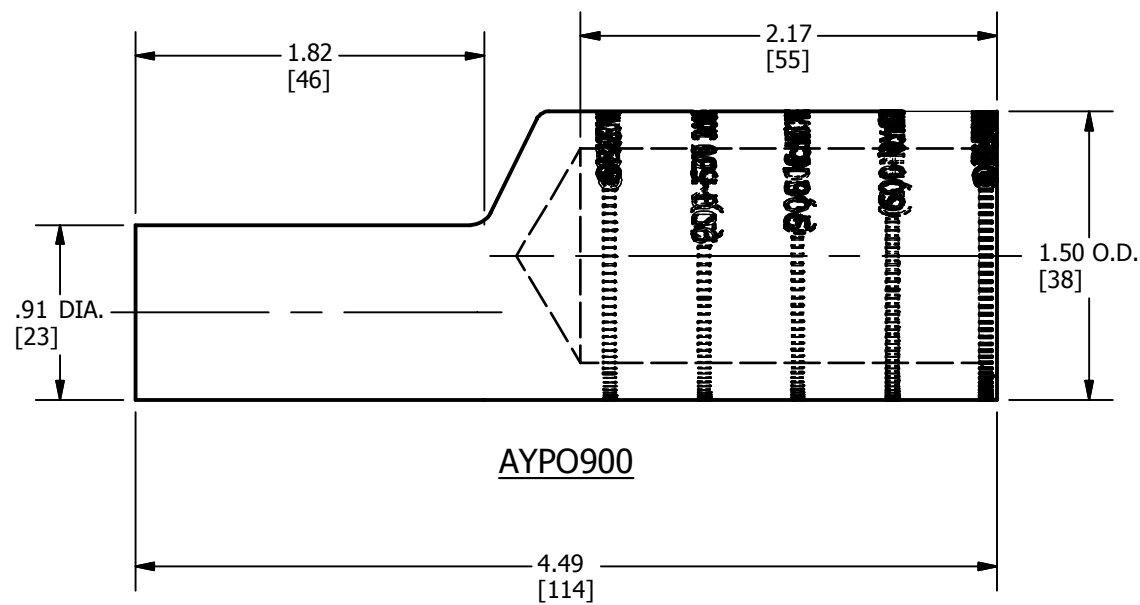
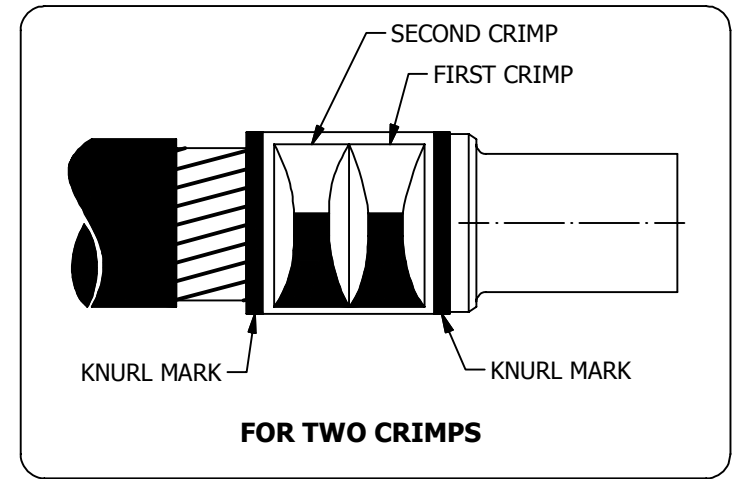

| |
|--|
| BURNDY AYP900 |
| 900-600 kcmil AL 90C Y644(2) |
| 900 kcmil AL 90C DIE 303(4) |
| 600 kcmil CU 90C Y644(2) |
| BURNDY AYP900 |

LETTERING VIEW

NOTES:

- MATERIAL: CONNECTOR - ALUMINUM WITH TIN PLATING.
INSULATING COVER - SANTOPRENE THERMOPLASTIC VULCANIZATE (TPV).
- BARREL IS PARTIALLY FILLED WITH PENETROX™ AND SEALED.
- SCRATCH BRUSHING OF ALL CONDUCTORS BEFORE MAKING INSTALLATION IS RECOMMENDED.
- CATALOG #PUADP-1 ADAPTOR IS REQUIRED TO USE "U" DIES IN Y46 SERIES TOOLS.
- U42ART DIE IS FOR 900 kcmil AL ONLY.
- CONNECTORS ARE LISTED FOR USE WITH 600-900 KCMIL AL OR 600 KCMIL CU USING THE Y644 TOOL ONLY.
- "UL" LISTED AND "CSA" CERTIFIED WIRE CONNECTOR, RATED 90°C AND UP TO 35KV.
- COVER IS "UL" LISTED AND "CSA" CERTIFIED INSULATING COVER. RATED 90°C, 600 V AND HAS A FLAMMABILITY RATING OF V-1 PER UL 94.
- DIMENSIONS IN BRACKETS [] ARE IN MILLIMETERS ROUNDED OFF TO THE NEAREST MILLIMETER, UNLESS OTHERWISE SPECIFIED AND ARE FOR REFERENCE ONLY.

| | | | |
|---|--|-------------------------------------|--|
| TO ORDER BURNDY® PRODUCTS CALL | | E-LINE HYLUG™ COMPRESSION TERMINALS | |
| UNITED STATES 1-800-346-4175 (LONDONDERRY, NH) | | ITEM NO: SEE TABLE | |
| CANADA: 1-800-361-6975 (QUEBEC) 1-800-387-6487 (ALL OTHER PROVINCES) | | CAT. NO: SEE TABLE | |
| FOR PRODUCT INFO: http://www.burndy.com | | DRAWN BY: N.D.KANNAN 10/29/2014 | |
| | | CHECKER: R.ROMAN 5/12/2015 | |
| | | DSN APRVL: R.ROMAN 5/12/2015 | |
| | | MFG APRVL: J.SMITH 5/12/2015 | |
| | | QA APRVL: T.WATTS 5/12/2015 | |
| | | MKT APRVL: B.MICHAUD 5/12/2015 | |
| | | PROJ #: | |
| | | SIZE | |
| | | DRAWING NO | |
| | | REV | |
| | | 50052442 | |
| | | C | |
| | | SHEET 1 OF 1 | |