

REV	DATE	DESCRIPTION	ECO	BY	C'H'K.
A	10/28/2014	INITIAL RELEASE	38101	MG	RM

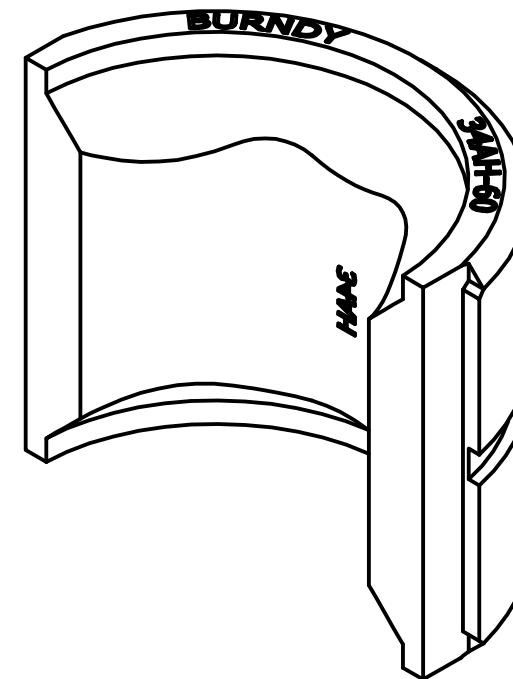
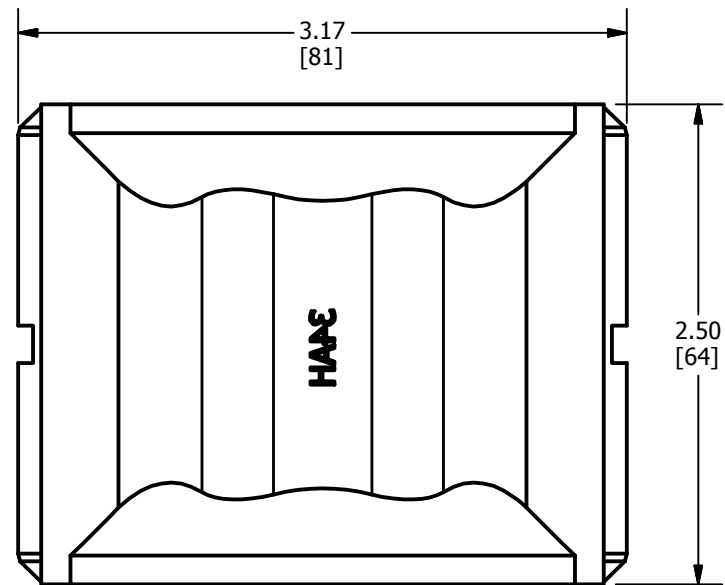
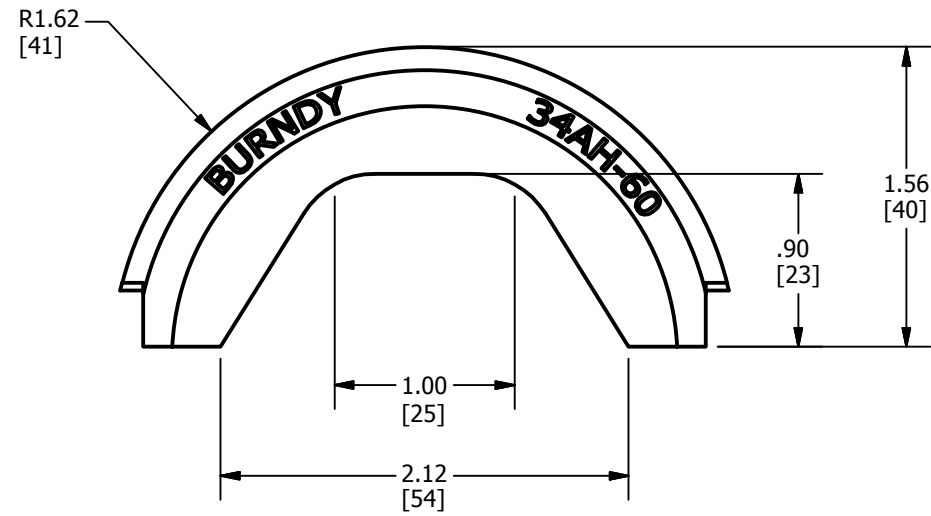

NOTES:

1. INTERPRET THIS DRAWING PER ASME 14.5M-2009
2. DIMENSIONS IN BRACKETS [] ARE IN MILLIMETERS ROUNDED OFF TO THE NEAREST MILLIMETER, UNLESS OTHERWISE SPECIFIED AND ARE FOR REFERENCE ONLY.
3. MATERIAL: STAINLESS STEEL
4. CATALOG NO. 34AH-60 TWIN DIE SET CONSISTS OF TWO SINGLE DIES AS SHOWN.

TO ORDER BURNDY® PRODUCTS CALL		34AH-60	
UNITED STATES 1-800-346-4175 (LONDONDERRY, NH)		ITEM NO: 50047157	
CANADA: 1-800-361-6975 (QUEBEC) 1-800-387-6487 (ALL OTHER PROVINCES)		CAT. NO: 34AH-60	
FOR PRODUCT INFO: http://www.burndy.com		DRAWN BY: D. Paquette 06-10-2014	
		CHECKER: J.LEFAVOUR 11-24-2014	
		DSN APRVL: J.LEFAVOUR 11-24-2014	
		MFG APRVL: A.JOHNS 11-22-2014	
		QA APRVL: C.LINDQUIST 12-02-2014	
		MKT APRVL: --	
		PROD FAM: --	
		DRAWING NO	
		50052514	
		REV	
		A	
		SIZE	
		B	
		DOCUMENT TYPE: SALES	
		REL LEVEL: Released	
		SHEET 1 OF 1	