

WILEY BUNDLE STRAP		
CATALOG #	LENGTH (L)	BUNDLE DIA.
WBS8V	203.2 [8.00]	19-57 [.75-2.24]
WBS10V	254.0 [10.00]	19-72 [.75-2.83]
WBS12V	304.8 [12.00]	19-88 [.75-3.50]
WBS14V	355.6 [14.00]	19-105 [.75-4.13]
WBS20V	508.0 [20.00]	19-161 [.75-6.33]
WBS24V	609.6 [24.00]	19-198 [.75-7.80]
WBS30V	762.0 [30.00]	19-237 [.75-9.33]
WBS36V	914.4 [36.00]	19-287 [.75-11.30]

REV	DATE	DESCRIPTION	EC	BY	CHK.
F	10-18-2023	DRAWING UPDATE	231019034159	TM	EM

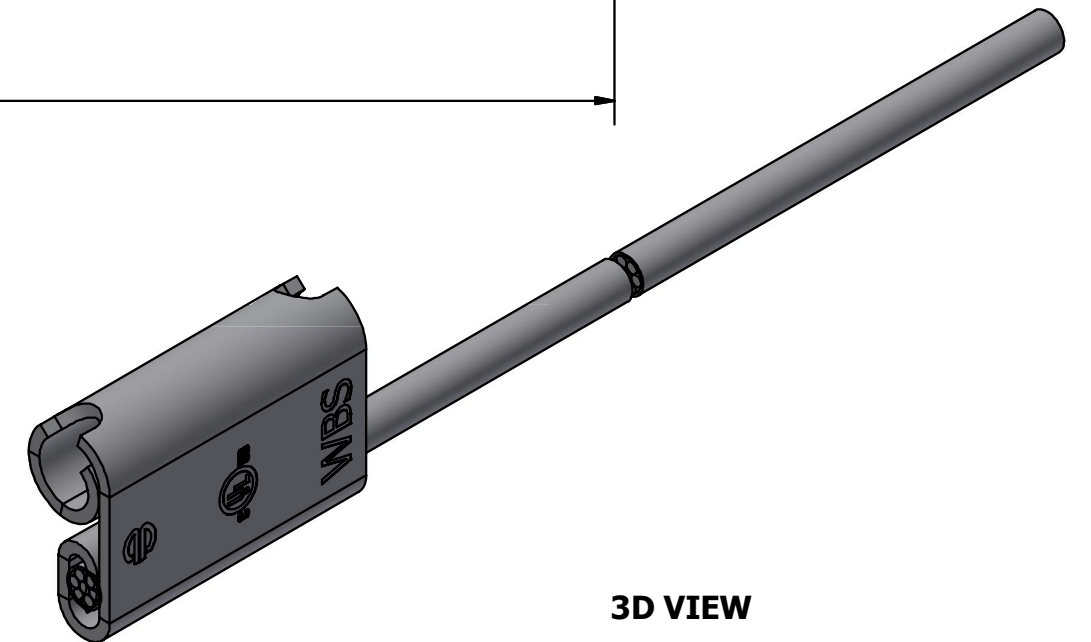
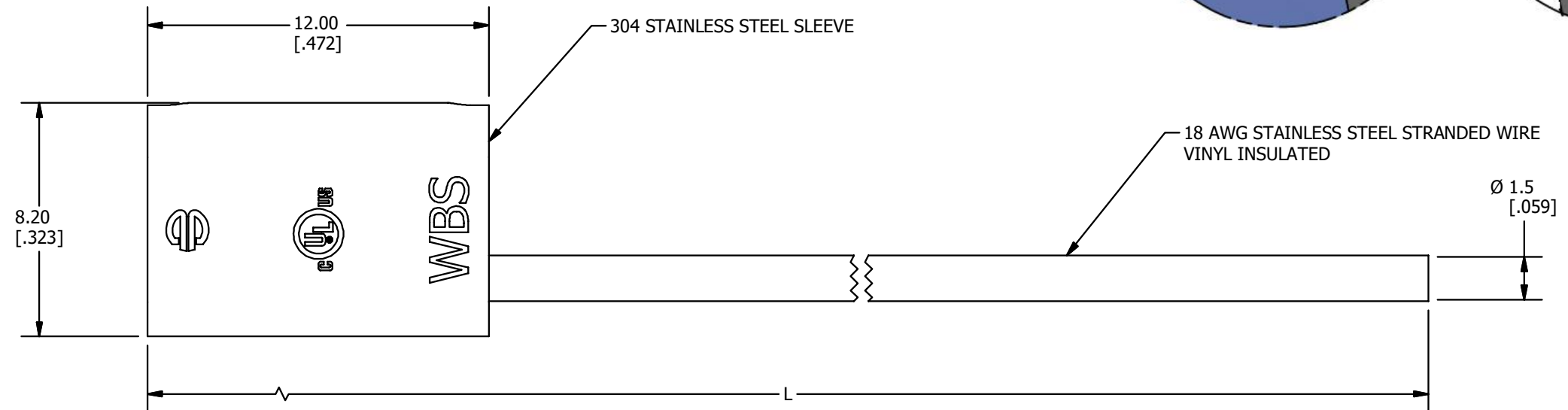
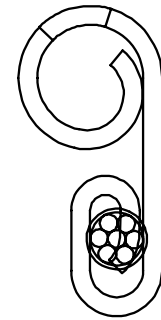
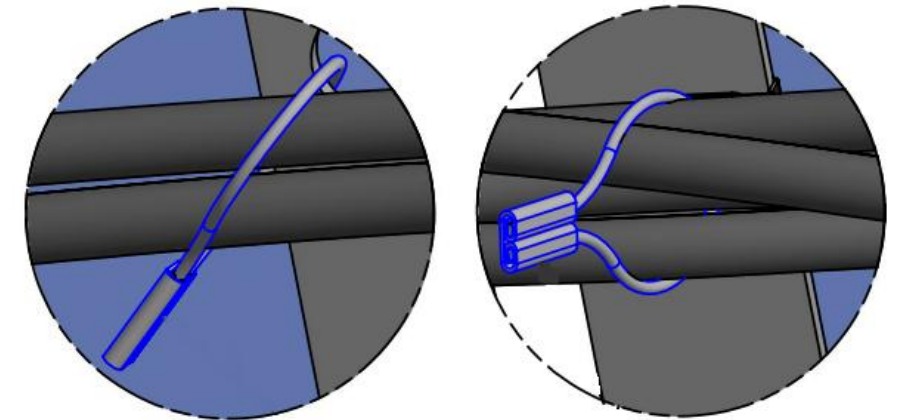

**3D VIEW**

**NOTES:**

1. MATERIAL: 304 STAINLESS STEEL FERRULE AND WIRE WITH UV-RATED VINYL JACKETING.
2. DIMENSIONS IN BRACKETS [ ] ARE IN INCHES ROUNDED OFF TO THE NEAREST TENTH, UNLESS OTHERWISE SPECIFIED AND ARE FOR REFERENCE ONLY.
3. FOR BUNDLES OF CABLE - EASY TO INSTALL AND CAN BE CRIMPED IN THE FIELD WITH ELECTRICIAN LINESMAN PLIERS OR STANDARD WIRE CUTTERS.
4. TENSILE STRENGTH: 100 lbs
5. PRODUCTS ARE LISTED TO UL 62275 STANDARD FOR CABLE TIES FOR ELECTRICAL INSTALLATIONS.

TO ORDER BURNDY® PRODUCTS CALL		WILEY BUNDLE STRAP	
UNITED STATES 1-800-346-4175 (LONDONDERRY, NH)		ITEM NO: SEE TABLE	
CANADA: 1-800-387-6487		CAT. NO: SEE TABLE	
FOR PRODUCT INFO: <a href="http://www.burndy.com">http://www.burndy.com</a>		DRAWN BY: D.SHEA 04-26-2016	
		CHECKER: E.MARTIN 06-22-2023	
		DSN APRVL: E.MARTIN 06-22-2023	
		MFG APRVL: J.VERRANAULT 11-13-2023	
		QA APRVL: J.BRODEUR 01-30-2023	
		MKT APRVL: S.PARSONS 02-03-2023	
		PROD FAM: WILEY	
		DRAWING NO	
		50054219	
		REV	
		F	
		SHEET 1 OF 1	

