

COPPER CABLE		STUD SIZE INCH [MM]	INSTALLATION TOOLING (# OF CRIMPS)								CABLE STRIP LENGTH
COMMERCIAL (CODE CABLE)	NAVY CABLE		DIE INDEX	COLOR CODE	DIE LESS	HYDRAULIC TOOLS					
						DIE TYPE	Y35	Y39, Y750, PAT750	Y45 ³	Y46 ⁴	
300 kcmil	N300 (91)	1/2 [M12]	17	WHITE	Y644M, Y644MBH	DIE SET	U30RT (2)	U30RT (2)	U30RT (2)	U30RT (2)	[1-1/8] 28.4
--	--		1024	--	1 CRIMP	NEST INDENTOR	--	P31D Y45PR5	P31D Y45PR5	P31D Y45PR5	

REV	DATE	DESCRIPTION	ECO	BY	C'H'K.
A	01/14/2015	CREATE NEW SALES DRAWING	38890	TS	BSB

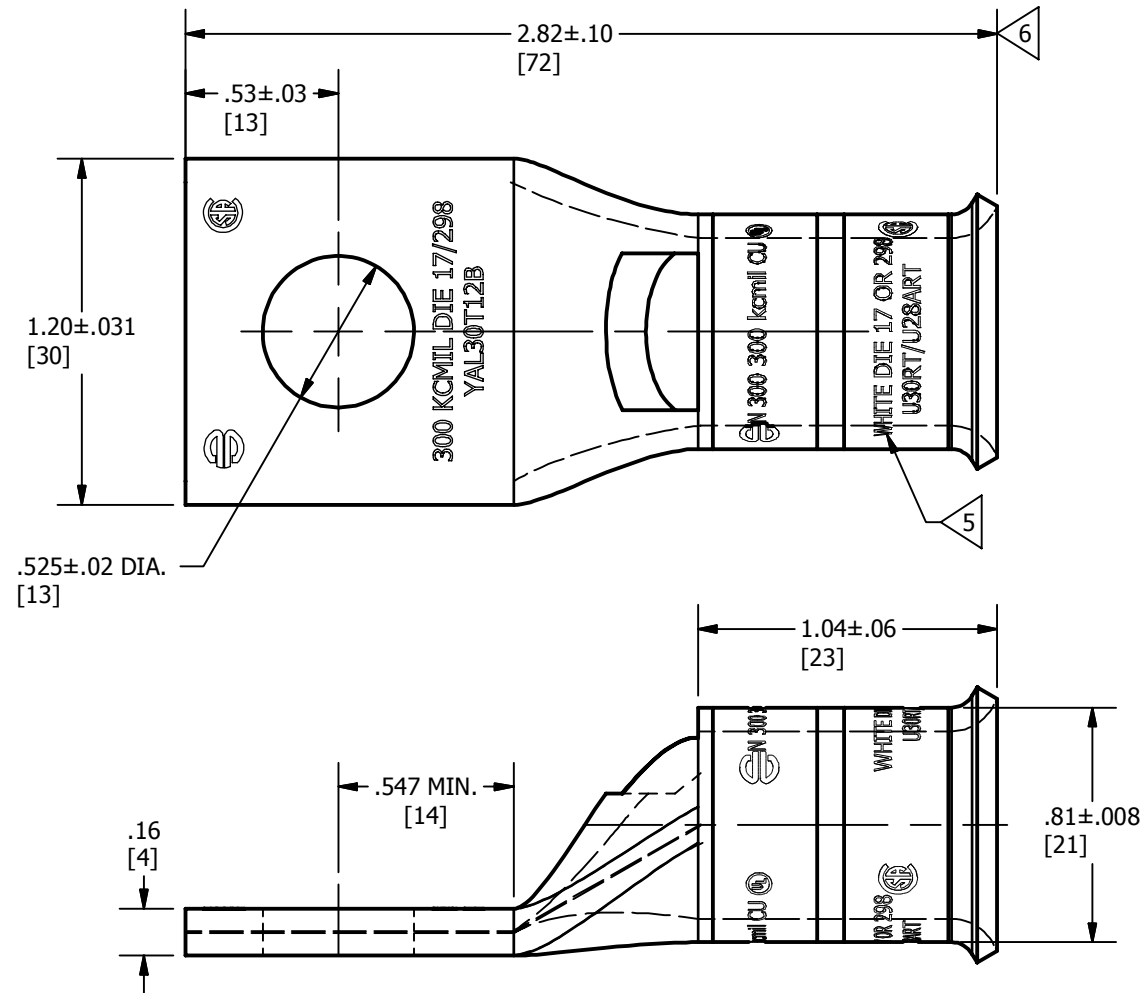

NOTES:

1. MATERIAL: COPPER TUBING.
2. FINISH: TIN PLATED.
3. CATALOG # PT6515 ADAPTOR IS REQUIRED TO USE "U" DIES IN Y45 SERIES TOOLS.
4. CATALOG # P-UADP ADAPTOR IS REQUIRED TO USE "U" DIES IN Y46 SERIES TOOLS.
5. LETTERING INFORMATION ON NATIONAL ELECTRIC CODE CONDUCTORS ACCOMMODATED IS ON COLOR CODED BARREL.
6. MEASURED TO THE SHORTEST POINT ON THE BELL.
7. DIMENSIONS IN BRACKETS [] ARE IN MILLIMETERS ROUNDED OFF TO THE NEAREST MILLIMETER, UNLESS OTHERWISE SPECIFIED AND ARE FOR REFERENCE ONLY.

TO ORDER BURNDY PRODUCTS CALL		HYLUG™	
UNITED STATES 1-800-346-4175 (LONDONDERRY, NH)		ITEM NO: 10054941	
CANADA: 1-800-361-6975 (QUEBEC) 1-800-387-6487 (ALL OTHER PROVINCES)		CAT. NO: YAL30T12B	
FOR PRODUCT INFO: http://www.burndy.com		DRAWN BY: T.SATHISH 1/13/2015	
		CHECKER: R.ROMAN 1/21/2015	
		DSN APRVL: R.ROMAN 1/21/2015	
		MFG APRVL: --	
		QA APRVL: T.WATTS 1/21/2015	
		MKT APRVL: B.MICHAUD 2/28/2015	
		PROD FAM: CM&R COMPRESSION	
		DRAWING NO	
		50054915	
		REV	
		A	
		SHEET 1 OF 1	