

| REV | DATE       | DESCRIPTION     | ECO   | BY | C'H'K. |
|-----|------------|-----------------|-------|----|--------|
| A   | 01/12/2015 | INITIAL RELEASE | 38858 | MG | RM     |

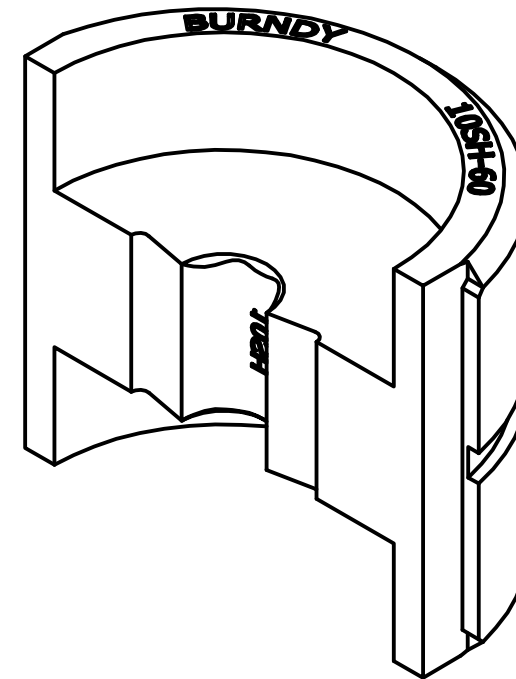
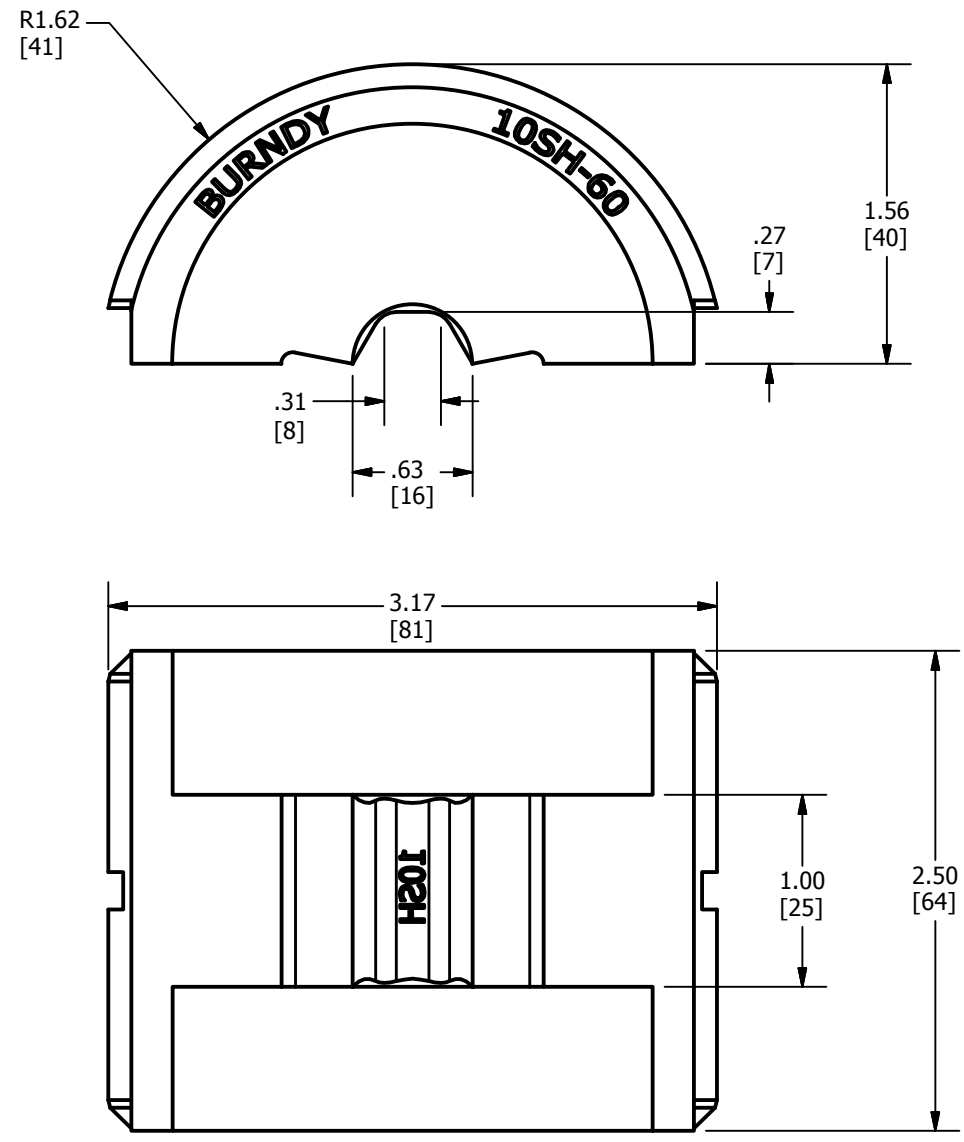

**NOTES:**

1. INTERPRET THIS DRAWING PER ASME 14.5M-2009
2. DIMENSIONS IN BRACKETS [ ] ARE IN MILLIMETERS ROUNDED OFF TO THE NEAREST MILLIMETER, UNLESS OTHERWISE SPECIFIED AND ARE FOR REFERENCE ONLY.
3. MATERIAL: STAINLESS STEEL

|   |  |                                  |  |
|---|--|----------------------------------|--|
| TO ORDER BURNDY® PRODUCTS CALL  |  | 10SH-60                          |  |
| UNITED STATES<br>1-800-346-4175 (LONDONDERRY, NH)                           |  | ITEM NO: 50047129                |  |
| CANADA:<br>1-800-361-6975 (QUEBEC)<br>1-800-387-6487 (ALL OTHER PROVINCES)  |  | CAT. NO: 10SH-60                 |  |
| FOR PRODUCT INFO: <a href="http://www.burndy.com">http://www.burndy.com</a> |  | DRAWN BY: D. Paquette 06-10-2014 |  |
|   |  | CHECKER: J.LEAF0UR 01-30-2015    |  |
|   |  | DSN APRVL: J.LEAF0UR 01-30-2015  |  |
|   |  | MFG APRVL: A.JOHNS 01-30-2015    |  |
|   |  | QA APRVL: C.LINDQUIST 01-30-2015 |  |
|   |  | MKT APRVL: --                    |  |
|   |  | PROD FAM: --                     |  |
|   |  | DRAWING NO                       |  |
|   |  | 50055102                         |  |
|   |  | REV                              |  |
|   |  | A                                |  |
|   |  | SHEET 1 OF 1                     |  |