

ITEM NUMBER	CATALOG NUMBER	ITEM NUMBER	CATALOG NUMBER	DIA. "A"	THREAD PER INCH	ACROSS FLATS "B"	ACROSS CORNERS "C"	THICKNESS "D"
058130	25CHEN	058042	25CHENET	1/4	20	.438/.428 [11]/[11]	.505/.488 [13]/[12]	.226/.212 [6]/[5]
058140	31CHEN	058050	31CHENET	5/16	18	.500/.489 [13]/[12]	.577/.557 [15]/[14]	.273/.258 [7]/[7]
058150	38CHEN	058550	38CHENET	3/8	16	.563/.551 [14]/[14]	.650/.628 [17]/[16]	.337/.320 [9]/[8]
058160	44CHEN	10008251	44CHENET	7/16	14	.688/.675 [17]/[17]	.794/.768 [20]/[20]	.385/.365 [10]/[9]
058170	50CHEN	058655	50CHENET	1/2	13	.750/.736 [19]/[19]	.866/.840 [22]/[21]	.448/.427 [11]/[11]
058180	56CHEN	10102923	56CHENET	9/16	12	.875/.861 [22]/[22]	1.010/.982 [26]/[25]	.496/.473 [13]/[12]
058190	62CHEN	10008252	62CHENET	5/8	11	.938/.922 [24]/[23]	1.083/1.051 [28]/[27]	.559/.535 [14]/[14]
058200	75CHEN	10064694	75CHENET	3/4	10	1.125/1.088 [29]/[28]	1.299/1.240 [33]/[31]	.665/.617 [17]/[16]
50050283	88CHEN	50050284	88CHENET	7/8	9	1.312/1.269 [33]/[32]	1.516/1.447 [39]/[37]	.776/.724 [20]/[18]
10064126	100CHEN	10067161	100CHENET	1	8	1.500/1.450 [38]/[37]	1.732/1.653 [44]/[42]	.887/.831 [23]/[21]

REV	DATE	DESCRIPTION	ECO	BY	C'H'K.
C	07/23/2020	UPDATED NOTES	53926	SS	YR

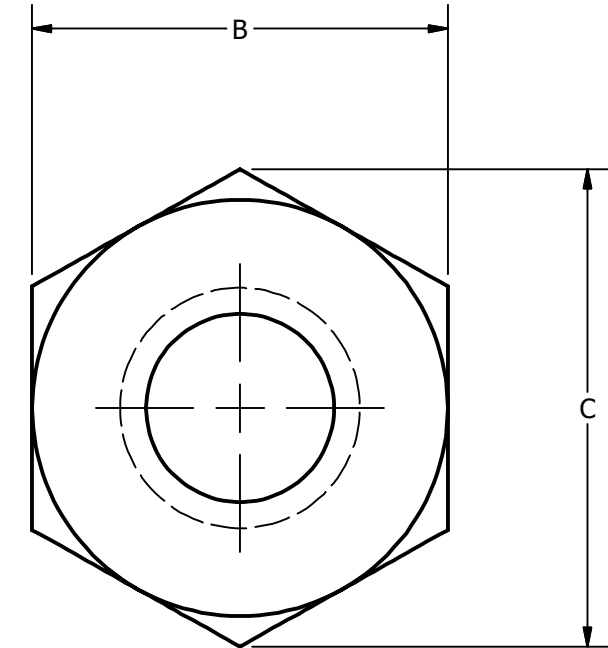
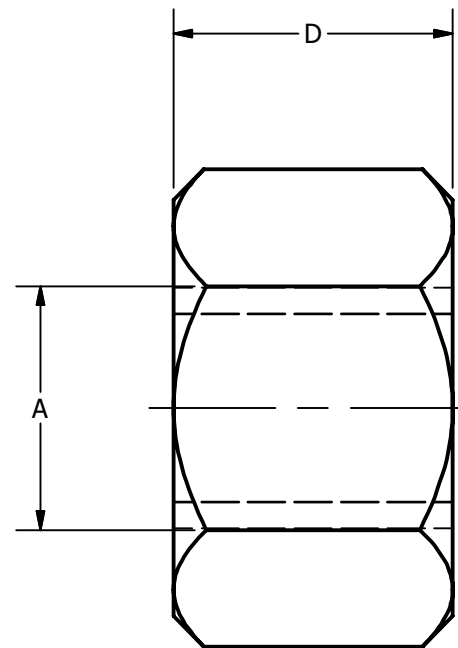

**NOTES:**

1. MATERIAL: SILICON BRONZE.
2. ALL THREADS ARE OF THE UNIFIED NATIONAL COARSE THREAD SERIES CLASS 2B.
3. ET SUFFIX DENOTES ELECTRO TIN PLATING.
4. DIMENSIONS IN BRACKETS [ ] ARE IN MILLIMETERS ROUNDED OFF TO THE NEAREST MILLIMETER, UNLESS OTHERWISE SPECIFIED AND ARE FOR REFERENCE ONLY.

TO ORDER BURNDY® PRODUCTS CALL  UNITED STATES 1-800-346-4175 (LONDONDERRY, NH)  CANADA: 1-800-361-6975 (QUEBEC) 1-800-387-6487 (ALL OTHER PROVINCES)  FOR PRODUCT INFO: <a href="http://www.burndy.com">http://www.burndy.com</a>	<b>AMERICAN STANDARD NUTS</b>	
	ITEM NO: SEE TABLE CAT. NO: SEE TABLE DRAWN BY: D.DHEENA 4/22/2015 CHECKER: G.RUGGIERO 5/15/2015 DSN APRVL: G.RUGGIERO 5/15/2015 MFG APRVL: P.KEENAN 5/5/2015 QA APRVL: C.KOWALCZYK 5/7/2015 MKT APRVL: R.CAVANAUGH 5/5/2015 PROD FAM: --	
PROJECT #: -- DOCUMENT TYPE: SALES REL LEVEL: Released	SIZE <b>B</b>	DRAWING NO <b>50059117</b> SHEET 1 OF 1
		<b>BURNDY</b> REV <b>C</b>