

DRAWING NO.
50061892

TYPE	CATALOG NO.	DESCRIPTION	QTY	NOMINAL INSTALLATION TORQUE
CAP MOUNTING HARDWARE KIT	MTG5C4 8	5/8-11 X 1.25 GALV STL HEX HEAD BOLTS	4	660 IN-LB [75 Nm]
		5/8 GALV STL SPLIT LOCKWASHER	4	
		5/8 GALV STL FLAT WASHER	4	
BASE MOUNTING HARDWARE KIT	MTG5B4 8	5/8-11 X 1.75 GALV STL HEX HEAD BOLTS	4	660 IN-LB [75 Nm]
		5/8 GALV STL SPLIT LOCKWASHER	4	
		5/8 GALV STL FLAT WASHER	4	
		5/8 GALV STL NUT	4	

REV	DATE	DESCRIPTION	ECO	BY	C'H'K.
A	06/30/2015 00:00:00 AM	CREATE STANDALONE SALES DRAWING FOR THE CATALOG# SH2GBP45A512B2	40808	MK	RL

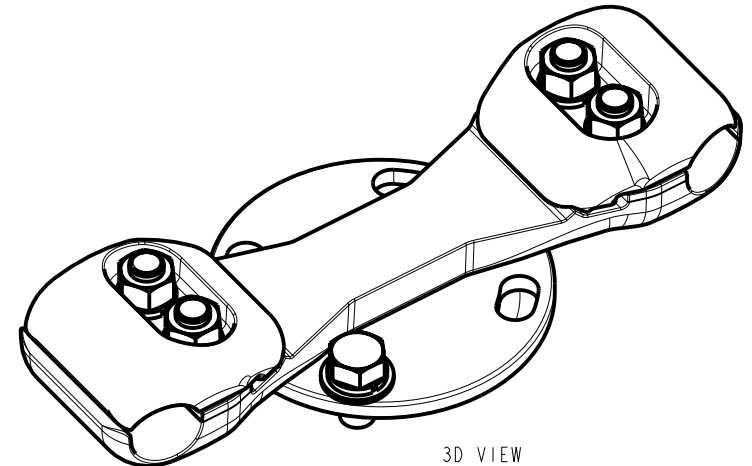
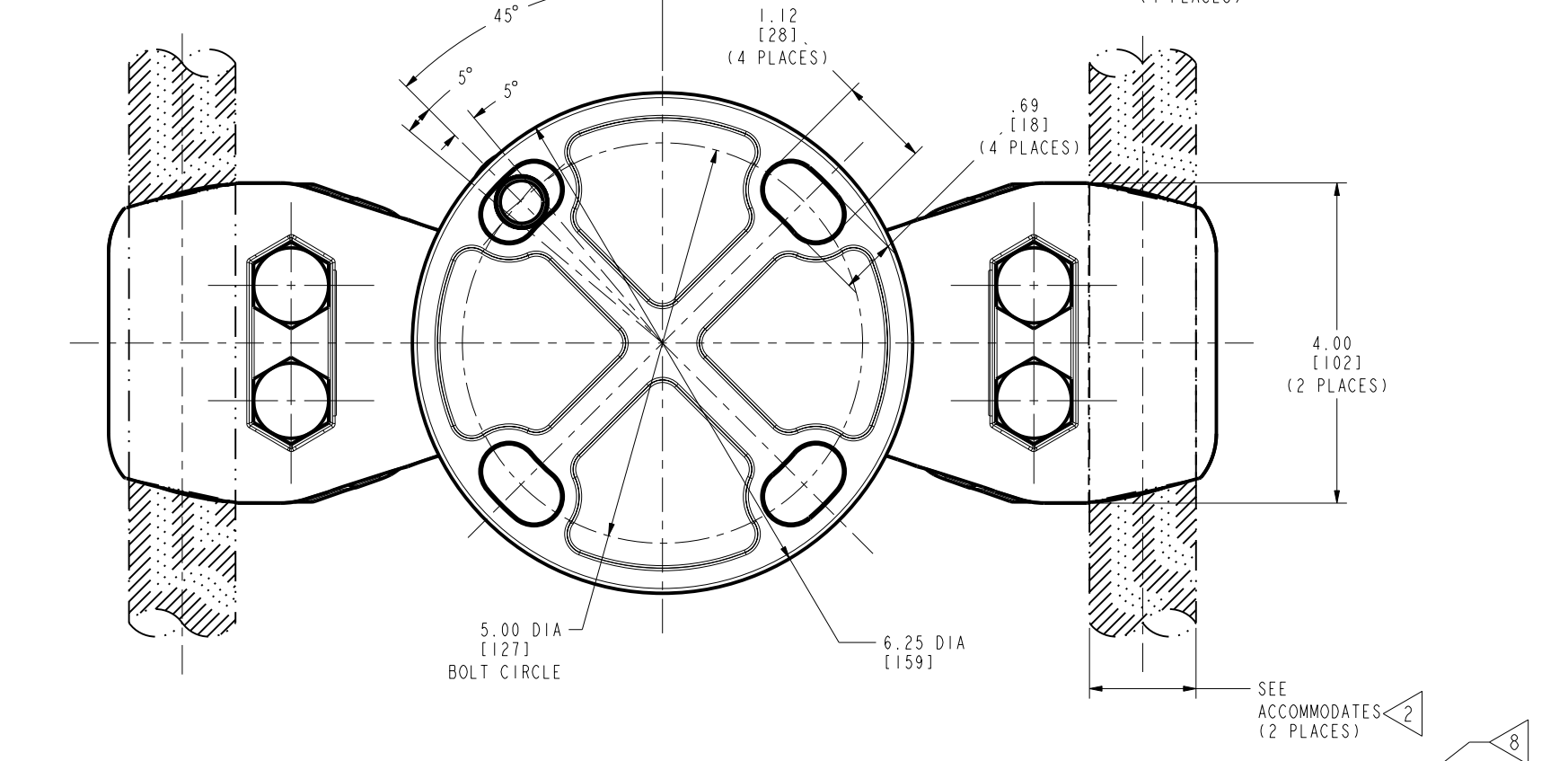
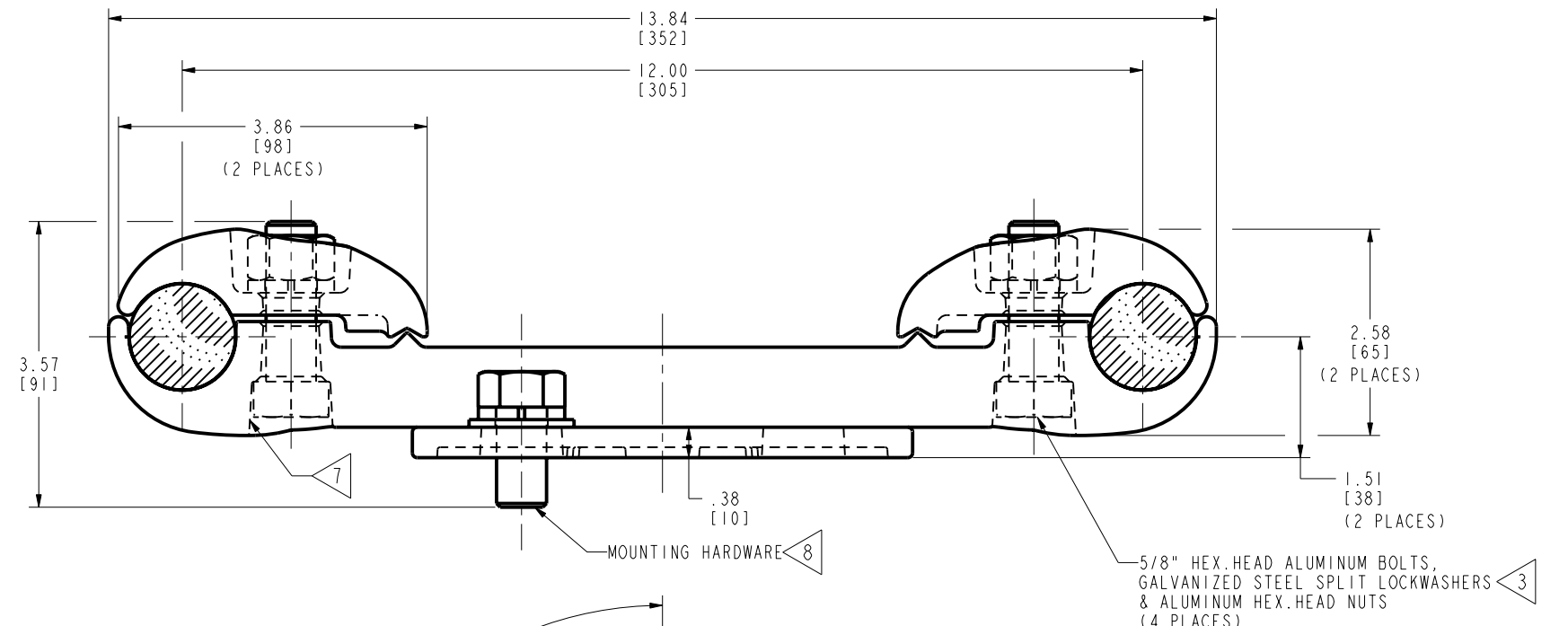

3D VIEW

NOTES:

- 1 MATERIAL:
BODY & CAP: CAST ALUMINUM ALLOY
- 2 ACCOMMODATES:
(2) 1033.5 Kcmil 54/7 STR (1.246 [32] DIA.) ACSR
1192.5 Kcmil 54/19 STR (1.333 [34] DIA.) ACSR
1192 Kcmil 61 STR (1.258 [32] DIA.) AAC
1272 Kcmil 61 STR (1.300 [33] DIA.) AAC
- 3 NOMINAL BOLT INSTALLATION TORQUE:
5/8" HEX. ALUMINUM HARDWARE 480 IN-LBS [55 Nm].
- 4 DIMENSIONS IN BRACKETS [] DENOTES METRIC UNITS [SI UNITS] AND ARE ROUNDED TO THE NEAREST WHOLE NUMBER. UNLESS OTHERWISE SPECIFIED THESE UNITS SHALL BE USED FOR REFERENCE ONLY.
- 5 SCRATCH BRUSH CONNECTOR CONTACT SURFACE DRY, THEN APPLY PENETROX™ A. PENETROX™ CAN BE PURCHASED FROM BURNDY LLC, IN CANS OR PLASTIC SQUEEZE BOTTLES.
- 6 THE CONCEPT SHOWN INCORPORATES PRINCIPLES WHICH PERMIT OPERATION AT A VOLTAGE GRADIENT NORMALLY ASSOCIATED WITH 500 KV RMS OPERATION PHASE TO PHASE.
- 7 HEX BOLTS CAPTURED TO PREVENT TURNING DURING INSTALLATION.
- 8 WHEN BASE MOUNTING IS SPECIFIED, THE CONNECTOR CATALOG NO IS FOLLOWED BY "B" AND THE MOUNTING HARDWARE WILL BE MTG5B4 PER BURNDY SPEC H232 (IN PLACE OF MTG5C4) (SEE TABLE) EXAMPLE: SH2GBP45A512B2B
- 9 MARKING:
BURNDY
SH2GBP45A512B2
1192 - 1272 Kcmil AAC
1033.5 - 1192.5 Kcmil ACSR

TO ORDER BURNDY® PRODUCTS CALL		BUS SUPPORT, 2 CONDUCTOR, EHV	
UNITED STATES 1-800-346-4175 (LONDONDERRY, NH)		ITEM NO: 26002108	SCALE: 1:1
CANADA: 1-800-361-6975 (QUEBEC) 1-800-387-6487 (ALL OTHER PROVINCES)		CAT. NO: SH2GBP45A512B2	REV
FOR PRODUCT INFO: http://www.burndy.com		DRAWN BY: M KATHIR 07/02/15	
		CHECKER: R LAVOIE 07/06/15	
		DSN APPVL: R LAVOIE 07/06/15	PROJ. NO
		MFG APPVL: T WAWRZYNIAK	SIZE
		QA APPVL: C KOWALCZYK 07/07/15	50061892
		MKT APPVL: S MOIST 07/06/15	SHEET 1 OF 1
		PROD FAM: SUBSTATION	D
		PROJECT #:	A
		DOCUMENT TYPE: Sales	
		REL LEVEL: Released	

REV: PEO200