

BURNDY® PRODUCTS - HYLUG™ & HARDWARE

ITEM NUMBER	CATALOG NUMBER	FIG. NO.	ACCOMMODATES ACCC® CONDUCTOR		5 CONTAINS HARDWARE KIT CAT. #	CTC NUMBER	DIMENSIONS								7 INSTALLATION TOOLING (NOT INCLUDED) TOOLS, DIE SETS			
			CODE WORD	SIZE			C	D	L	N	O.D.	I.D.	T	H	DIE INDEX	Y45	Y46	Y60
50055840	BYNA32RT15HACCCSS	1	LINNET ORIOLE	431 Kcmil	TMH94	600-153-1	3.25 [82]	4.50 [114]	15.5 [393]	1.12 [29]	1.19 [30]	.80 [20]	.50 [13]	4.05 [103]	717	S717	P717	L717W
30012139	BYNA32RT15HACCCGS		COPENHAGEN REYKJAVIK	438 Kcmil 230mm ² 235mm ²														
8 50055841	BYNA45IRT15HACCCSS	2	DRAKE STOCKHOLM WARSAW DUBLIN	1020 Kcmil 470mm ² 530mm ² 540mm ²	TMH94	600-253-5	3.22 [82]	3.95 [100]	15.0 [381]	.63 [16]	1.80 [46]	1.18 [30]	.45 [11]	4.45 [113]	725	S725	P725	L725W
50055842	BYNA56RT15HACCCSS	LAPWING	1949 Kcmil	TMH78	600-353-1	17.6 [447]												

REV	DATE	DESCRIPTION	ECO	BY	C.H.K.
A	10/12/2015 00:00:00 AM	DRAWING UPDATION PER MARKUPS	41822	AS	MB

5 CATALOG NO. TMH78 HARDWARE KIT CONSIST OF	
QTY.	DESCRIPTION
4	BOLT, HEX. HEAD 1/2"-13 X 2 1/2" LONG
4	HEX. NUT, 1/2"-13
4	FLAT WASHER 1/2"
4	RESILIENT WASHER 1/2"

5 CATALOG NO. TMH94; TMH338 HARDWARE KIT CONSIST OF	
QTY.	DESCRIPTION
4	BOLT, HEX. HEAD 1/2"-13 X 2" LONG
4	HEX. NUT, 1/2"-13
4	FLAT WASHER 1/2"
4	RESILIENT WASHER 1/2"

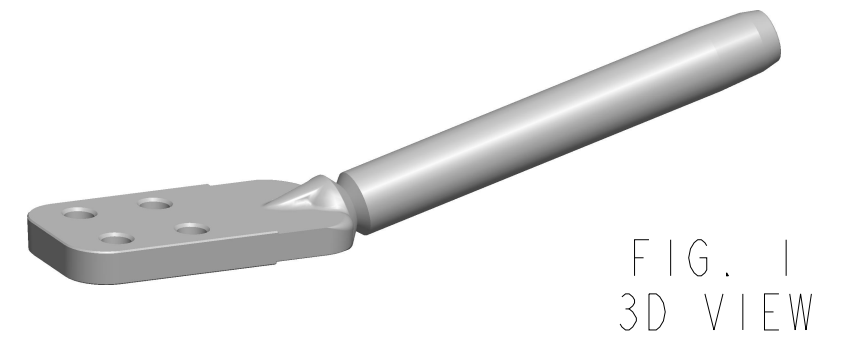
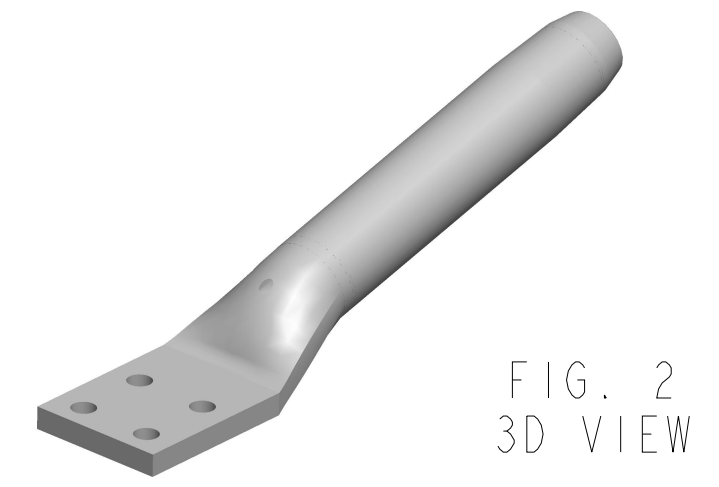
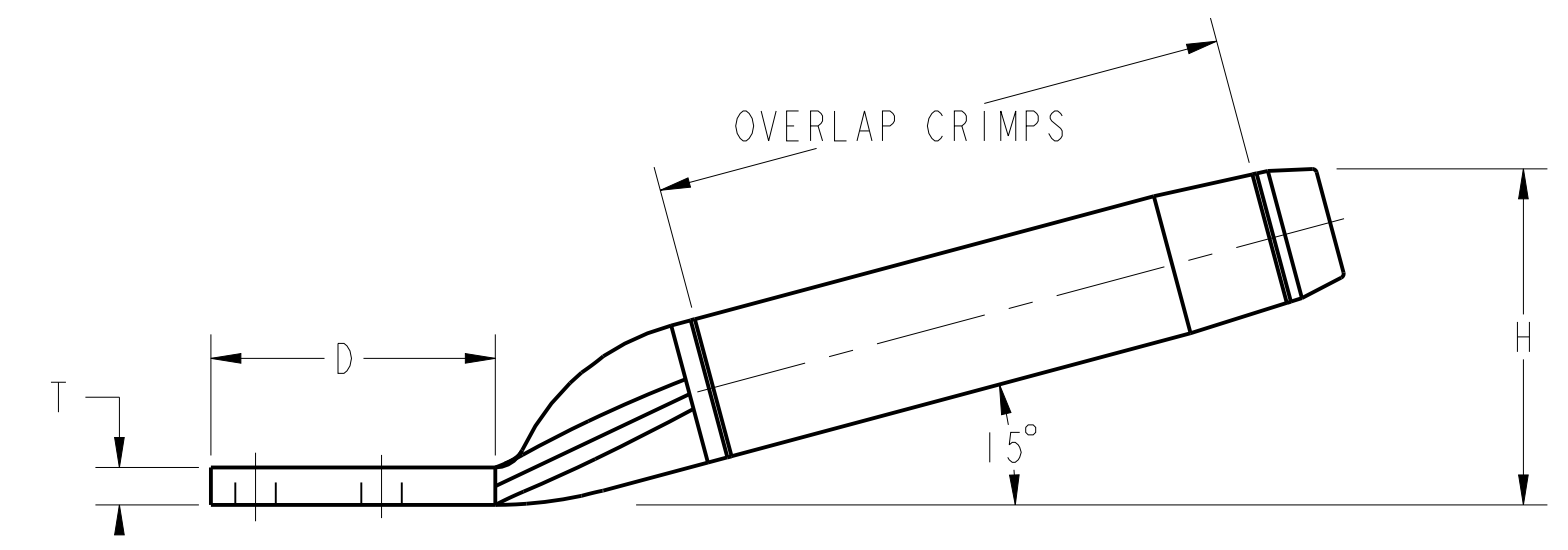
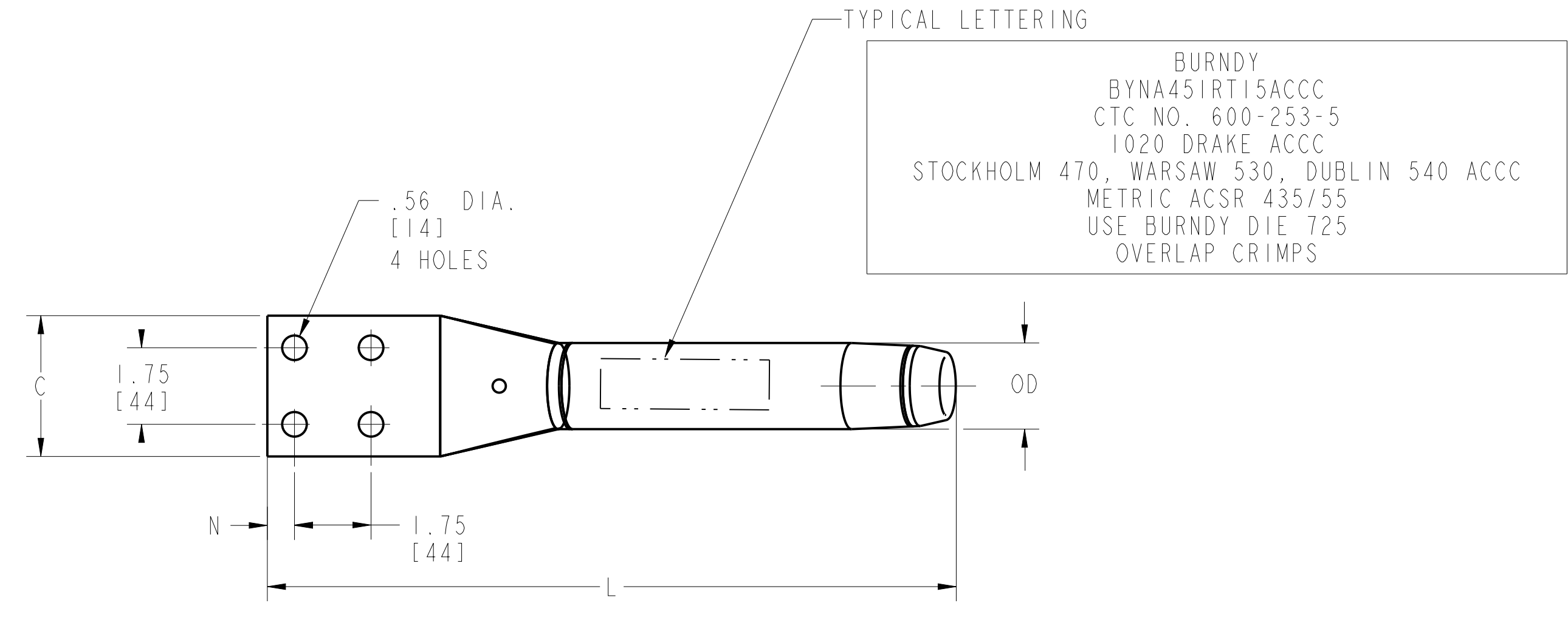

- NOTES:
- MATERIAL:
 - CONNECTOR, ALUMINUM ALLOY, NO-OX-ID COATED
 - ALUMINUM FILLER PLUG
 - TMH78 & TMH94 HARDWARE
 - BOLTS, NUTS, FLAT WASHERS, AND RESILIENT WASHERS ARE STAINLESS STEEL
 - TMH338 HARDWARE
 - BOLTS, NUTS, FLAT WASHERS, AND RESILIENT WASHERS ARE GALVANIZED STEEL
 - DIMENSIONS IN BRACKETS [] DENOTE METRIC UNITS [SI UNITS] AND ARE ROUNDED TO THE NEAREST WHOLE NUMBER. UNLESS OTHERWISE SPECIFIED THESE UNITS SHALL BE USED FOR REFERENCE ONLY.
 - DESIGNED FOR CORONA FREE OPERATION TO 230 KV NO ACCESSORIES REQUIRED.
 - CONNECTOR SHALL BE SHIPPED UN-ASSEMBLED.

5 RECOMMENDED TIGHTENING TORQUE: 1/2-13 STAINLESS STEEL AND GALVANIZED STEEL HARDWARE: 480 LBS-IN [54 NM]

6 REFERENCE: DRAWING 10093976.

7 REFERENCE: 10092621, CONNECTOR INSTALLATION

8 ACCOMMODATES METRIC ACSR 435/55.

COMPRESSION TERMINAL CONNECTOR FOR
(ACCC® ALUMINUM CONDUCTOR COMPOSITE CORE)

TO ORDER BURNDY® PRODUCTS CALL		15 DEG HYLUG™ & HARDWARE (ACCC)	
UNITED STATES 1-800-346-4175 (LONDONDERRY, NH)		ITEM NO: SEE TABLE	
CANADA: 1-800-361-6975 (QUEBEC) 1-800-387-6487 (ALL OTHER PROVINCES)		CAT. NO: SEE TABLE	
FOR PRODUCT INFO: http://www.burndy.com		DRAWN BY: ASWAMY 10/12/2015	
		CHECKER: BMANIKANDAN10/12/2015	
		DSN APPVL: PCHAN 10/08/2015	
		MFG APPVL: JHEAD 10/09/2015	
		QA APPVL: TWATTS 10/08/2015	
		MKT APPVL: BCRUTCHER 10/09/2015	
		PROD FAM: Transmissio/YNA	
		SCALE: 3:8	
		DRAWING NO	
		PROJECT #: --	
		SIZE	
		50064556	
		DOCUMENT TYPE: Sales	
		SHEET 1 OF 1	
		REV	
		A	

D

C

B

A

D

C

B

A

REV: PEC200