

6 ITEM NUMBER	CATALOG NUMBER	FIG. NO.	ACCOMMODATES ACCC® CONDUCTOR		5 CONTAINS HARDWARE KIT CAT. #	CTC NUMBER	DIMENSIONS								7 INSTALLATION TOOLING (NOT INCLUDED) TOOLS, DIE SETS				APPROXIMATE WEIGHT LBS
			CODE WORD	SIZE			C	D	L	N	O.D.	I.D.	T	H	DIE INDEX	Y45	Y46	Y60	
10092604	BYNA36RT15HACCC	1	CASABLANCA	285mm ²	TMH24	600-153-3	3.25	4.25	15.8	1.12	1.41	.92	.50	4.24	720	S720	P720	L720W	2.3
10092603	BYNA36RT15ACCC				--		[82]	[107]	[402]	[29]	[36]	[23]	[13]	[108]					

REV	DATE	DESCRIPTION	ECO	BY	C.H.K.
A	10/27/2015 00:00:00 AM	NEW DRAWING CREATED	41952	LM	MB

5 CATALOG NO. TMH24 HARDWARE KIT CONSIST OF	
QTY.	DESCRIPTION
4	BOLT, HEX. HEAD 1/2"-13 X 2" LONG
4	HEX. NUT, 1/2"-13
4	FLAT WASHER 1/2"
4	RESILIENT WASHER 1/2"

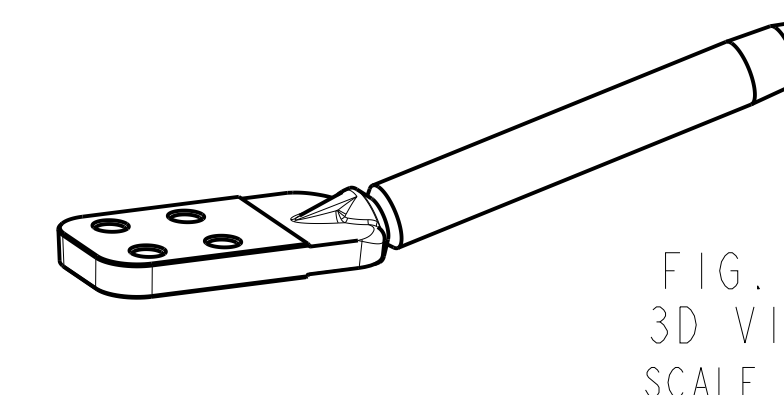
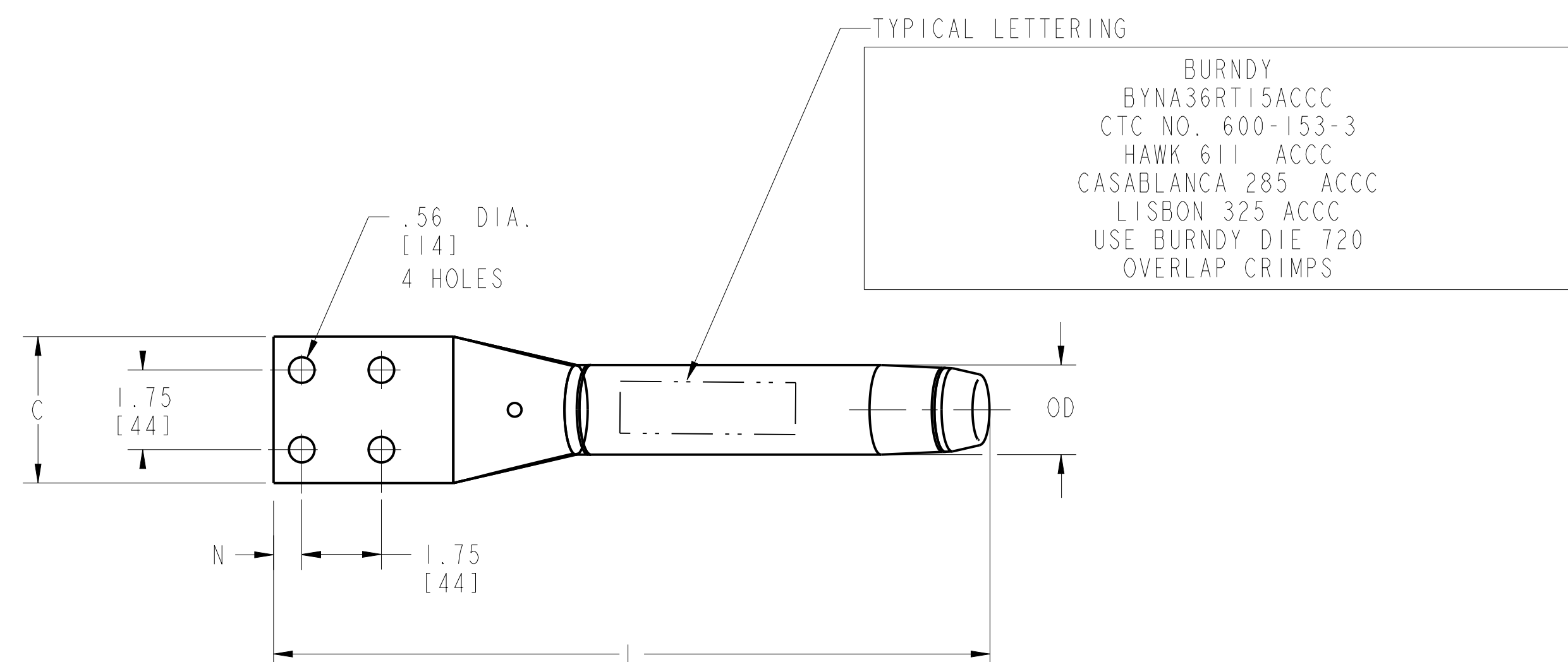

NOTES:

- MATERIAL:
 - CONNECTOR, ALUMINUM ALLOY, NO-OX-ID COATED
 - ALUMINUM FILLER PLUG
 - TMH24
 - BOLTS (2024 T4), NUTS (6061 T6) AND FLAT WASHERS, ALUMINUM ALLOY
 - RESILIENT WASHERS, GALVANIZED STEEL

2. DIMENSIONS IN BRACKETS [] DENOTE METRIC UNITS [SI UNITS] AND ARE ROUNDED TO THE NEAREST WHOLE NUMBER. UNLESS OTHERWISE SPECIFIED THESE UNITS SHALL BE USED FOR REFERENCE ONLY.

3. DESIGNED FOR CORONA FREE OPERATION TO 230 KV NO ACCESSORIES REQUIRED.

4. CONNECTOR SHALL BE SHIPPED UN-ASSEMBLED.

5 RECOMMENDED TIGHTENING TORQUE: 1/2-13 ALUMINUM HARDWARE: 300 LBS-IN [34 NM]

6 CATALOG NUMBER FOR HYLUG™ WITHOUT HARDWARE ARE CATALOG NUMBERS WITHOUT "H".

7 REFERENCE: 10092621, CONNECTOR INSTALLATION

COMPRESSION TERMINAL CONNECTOR FOR
(ACCC® ALUMINUM CONDUCTOR COMPOSITE CORE)

TO ORDER BURNDY® PRODUCTS CALL		15 DEG HYLUG™ & HARDWARE (ACCC)	
UNITED STATES		ITEM NO: SEE TABLE	
1-800-346-4175 (LONDONDERRY, NH)		CAT. NO: SEE TABLE	
CANADA:		DRAWN BY: LOKESH M 10/27/15	
1-800-361-6975 (QUEBEC)		CHECKER: MANIKANDAN B 10/28/15	
1-800-387-6487 (ALL OTHER PROVINCES)		DSN APPVL: P CHAN 10/22/15	
FOR PRODUCT INFO: http://www.burndy.com		MFG APPVL: J HEAD 10/22/15	
		QA APPVL: T WATTS 10/22/15	
		MKT APPVL: B CRUTCHER 10/22/15	
		PROD FAM: Transmissio/YNA	
		DRAWING NO	
		PROJECT #: --	
		SIZE	
		50064993	
		DOCUMENT TYPE: Sales	
		D	
		REL LEVEL: Released	
		SCALE: 3:8	
		SHEET 1 OF 1	

