

REV	DATE	DESCRIPTION	ECO	BY	CHK.
A	12/29/2015	DRAWING RELEASED	42274	MM	NJS

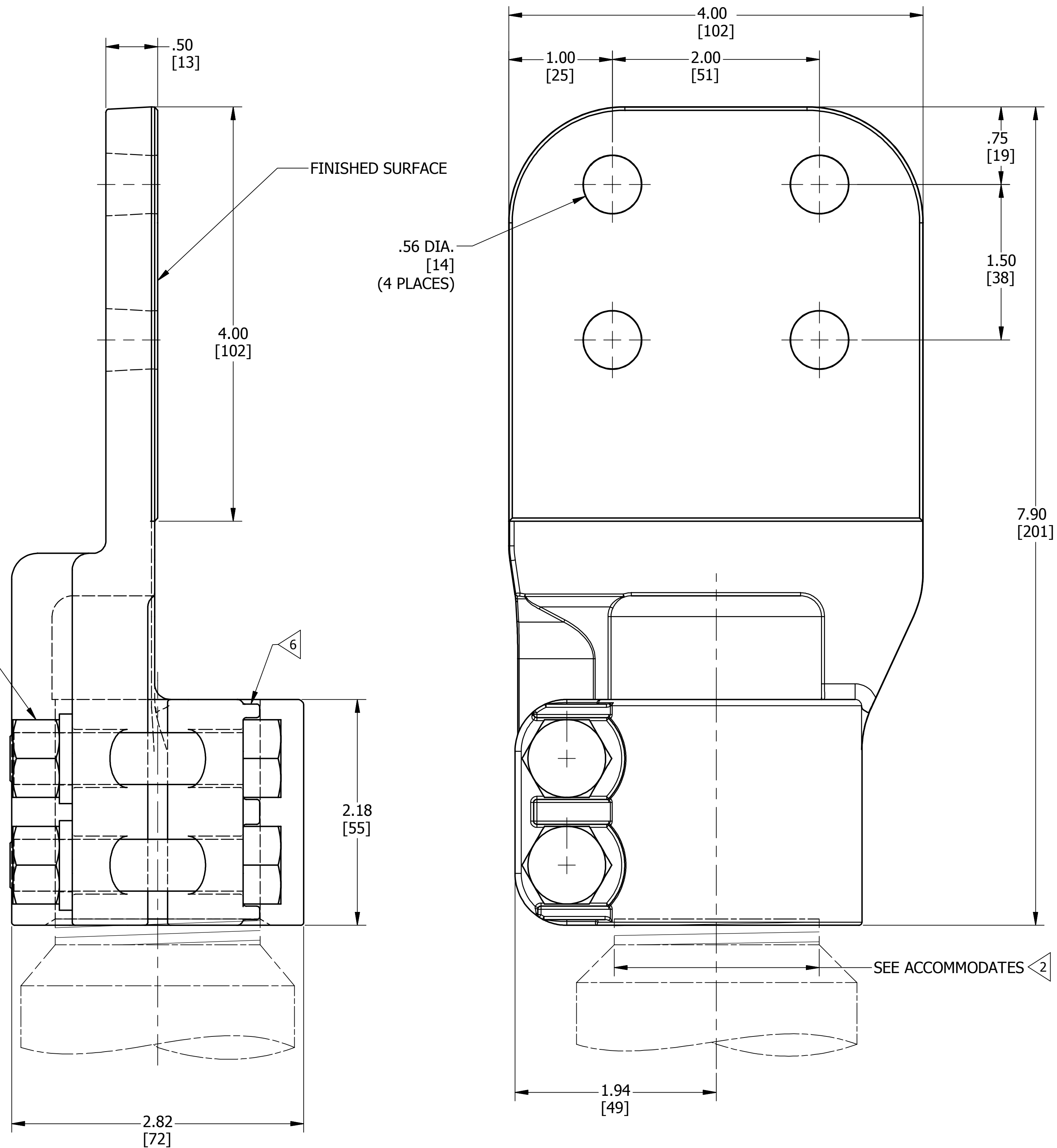
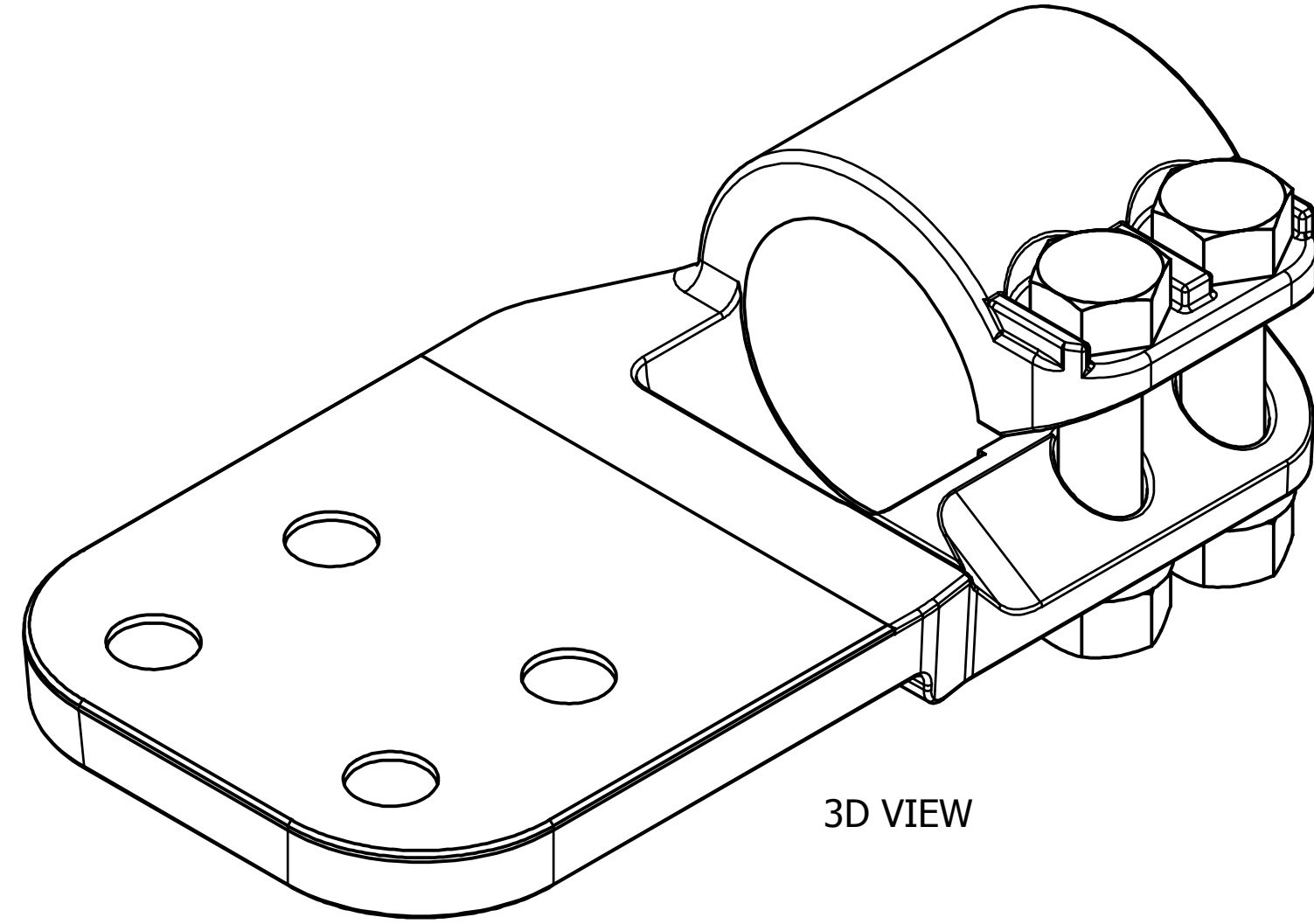

4 1/2"-13 SILICON BRONZE HEX HEAD BOLT, SILICON BRONZE SPLIT LOCK WASHER & SILICON BRONZE HEX NUT (2 PLACES)

- NOTES:
- MATERIAL: CAST COPPER ALLOY.
  - ACCOMMODATES: 2" -12UN TO 4 HOLE PAD.
  - DIMENSIONS IN BRACKETS [ ] ARE IN MILLIMETERS ROUNDED OFF TO THE NEAREST MILLIMETER, UNLESS OTHERWISE SPECIFIED AND ARE FOR REFERENCE ONLY.
  - NOMINAL BOLT INSTALLATION TORQUE VALUE: 1/2" HEX. SILICON BRONZE HARDWARE 480 LB-IN [55 Nm].
  - THE CONCEPT SHOWN INCORPORATES PRINCIPLES WHICH PERMIT OPERATION AT A VOLTAGE GRADIENT NORMALLY ASSOCIATED WITH 550 KV RMS OPERATION PHASE TO PHASE.
  - HEX BOLTS CAPTURED TO PREVENT TURNING DURING INSTALLATION.
  - MARKINGS:  
BURNDY  
FD68T1214  
2"-12 STUD TO .25T X 4.00 W COPPER BAR

TO ORDER BURNDY® PRODUCTS CALL		STUD CONNECTOR																															
UNITED STATES 1-800-346-4175 (LONDONDERRY, NH)		ITEM NO: 27001814																															
CANADA: 1-800-361-6975 (QUEBEC) 1-800-387-6487 (ALL OTHER PROVINCES)		CAT. NO: FD68T1214																															
FOR PRODUCT INFO: <a href="http://www.burndy.com">http://www.burndy.com</a>		<table border="1"> <tr> <td>DRAWN BY: M MOHAN</td> <td>2/1/2017</td> <td rowspan="5"></td> </tr> <tr> <td>CHECKER: NJ SUDHAKAR</td> <td>2/1/2017</td> </tr> <tr> <td>DSN APRVL: R LAVOIE</td> <td>3/14/2017</td> </tr> <tr> <td>MFG APRVL: T WAWRZYNIAK</td> <td>3/11/2017</td> </tr> <tr> <td>QA APRVL: J HILLMAN</td> <td>3/15/2017</td> </tr> <tr> <td>MKT APRVL: B CRUTCHER</td> <td>5/4/2017</td> <td></td> </tr> <tr> <td>PROD FAM: SUBSTATION</td> <td></td> <td>DRAWING NO</td> <td>REV</td> </tr> <tr> <td>PROJECT #: FPN1604086</td> <td>SIZE</td> <td>50066528</td> <td>A</td> </tr> <tr> <td>DOCUMENT TYPE: SALES</td> <td>D</td> <td colspan="2">SHEET 1 OF 1</td> </tr> <tr> <td>REL LEVEL: Released</td> <td></td> <td colspan="2"></td> </tr> </table>		DRAWN BY: M MOHAN	2/1/2017		CHECKER: NJ SUDHAKAR	2/1/2017	DSN APRVL: R LAVOIE	3/14/2017	MFG APRVL: T WAWRZYNIAK	3/11/2017	QA APRVL: J HILLMAN	3/15/2017	MKT APRVL: B CRUTCHER	5/4/2017		PROD FAM: SUBSTATION		DRAWING NO	REV	PROJECT #: FPN1604086	SIZE	50066528	A	DOCUMENT TYPE: SALES	D	SHEET 1 OF 1		REL LEVEL: Released			
DRAWN BY: M MOHAN	2/1/2017																																
CHECKER: NJ SUDHAKAR	2/1/2017																																
DSN APRVL: R LAVOIE	3/14/2017																																
MFG APRVL: T WAWRZYNIAK	3/11/2017																																
QA APRVL: J HILLMAN	3/15/2017																																
MKT APRVL: B CRUTCHER	5/4/2017																																
PROD FAM: SUBSTATION		DRAWING NO	REV																														
PROJECT #: FPN1604086	SIZE	50066528	A																														
DOCUMENT TYPE: SALES	D	SHEET 1 OF 1																															
REL LEVEL: Released																																	