

BURNDY® PRODUCTS - HYLUG™ & HARDWARE

6 ITEM NUMBER	CATALOG NUMBER	FIG. NO.	ACCOMMODATES ACCC® CONDUCTOR		5 CONTAINS HARDWARE KIT CAT. #	CTC NUMBER	DIMENSIONS								7 INSTALLATION TOOLING (NOT INCLUDED) TOOLS, DIE SETS				APPROXIMATE WEIGHT LBS
			CODE WORD	SIZE			C	D	L	N	O.D.	I.D.	T	H	DIE INDEX	Y45	Y46	Y60	
10092601	BYNA32RT15HACCC	1	COPENHAGEN	230mm ²	TMH24	600-153-1	3.25	4.50	15.5	1.12	1.19	.80	.50	4.05	717	S717	P717	L717W	--
10092600	BYNA32RT15ACCC				--		[82]	[114]	[393]	[29]	[30]	[20]	[13]	[103]					

REV	DATE	DESCRIPTION	ECO	BY	C.H.K.
A	02/23/2016 00:00:00 AM	NEW DRAWING CREATED	42864	CV	MB

5 CATALOG NO. TMH24 HARDWARE KIT CONSIST OF	
QTY.	DESCRIPTION
4	BOLT, HEX. HEAD 1/2"-13 X 2" LONG
4	HEX. NUT, 1/2"-13
4	FLAT WASHER 1/2"
4	RESILIENT WASHER 1/2"

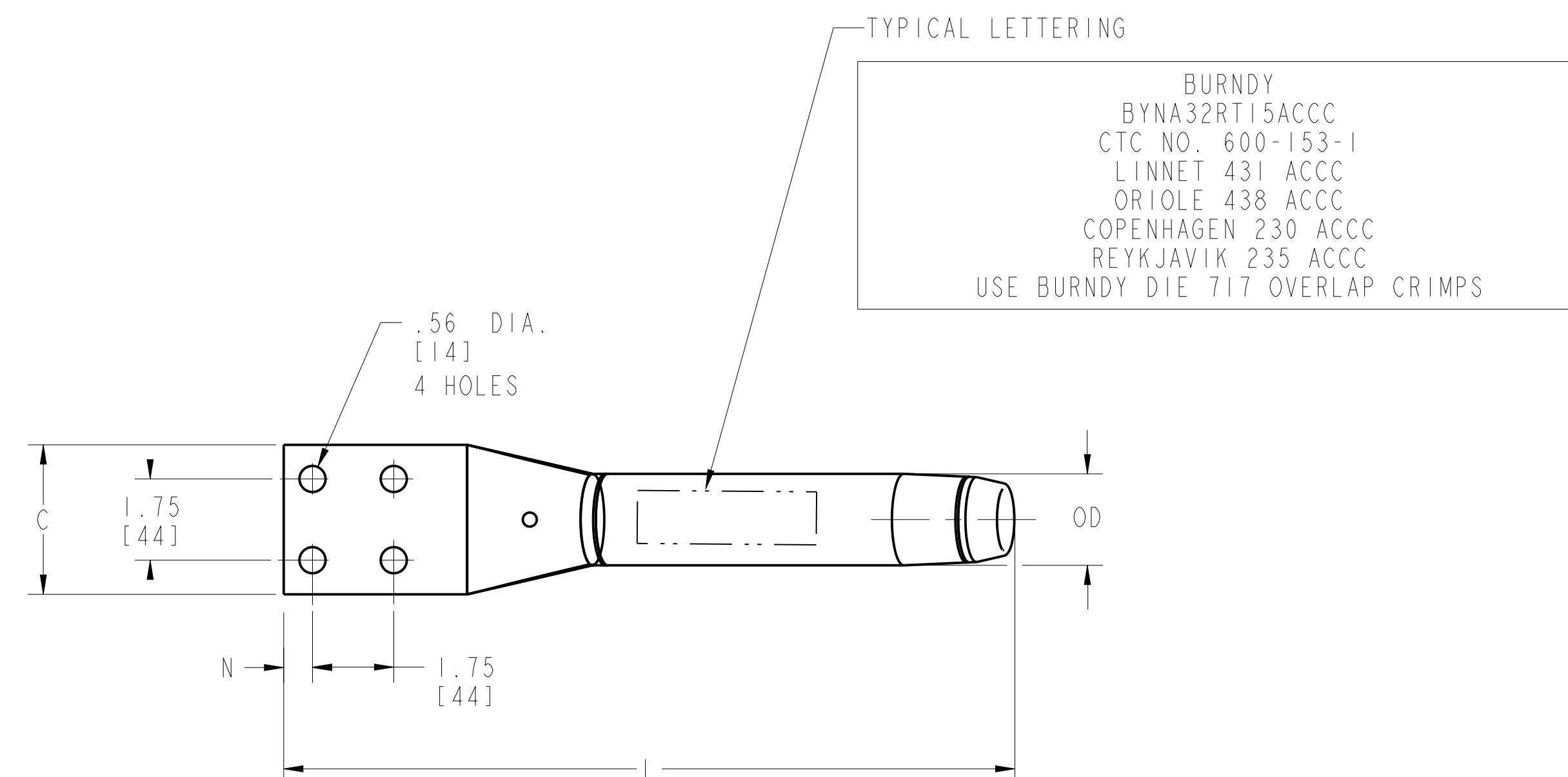

NOTES:

- MATERIAL:
 - CONNECTOR, ALUMINUM ALLOY, NO-OX-ID COATED
 - ALUMINUM FILLER PLUG
 - TMH24
 - BOLTS (2024 T4), NUTS (6061 T6) AND FLAT WASHERS, ALUMINUM ALLOY
 - RESILIENT WASHERS, GALVANIZED STEEL

2. DIMENSIONS IN BRACKETS [] DENOTE METRIC UNITS [SI UNITS] AND ARE ROUNDED TO THE NEAREST WHOLE NUMBER. UNLESS OTHERWISE SPECIFIED THESE UNITS SHALL BE USED FOR REFERENCE ONLY.

3. DESIGNED FOR CORONA FREE OPERATION TO 230 KV NO ACCESSORIES REQUIRED.

4. CONNECTOR SHALL BE SHIPPED UN-ASSEMBLED.

5 RECOMMENDED TIGHTENING TORQUE: 1/2-13 ALUMINUM HARDWARE: 300 LBS-IN [34 NM]

6 CATALOG NUMBER FOR HYLUG™ WITHOUT HARDWARE ARE CATALOG NUMBERS WITHOUT "H".

7 REFERENCE: 10092621, CONNECTOR INSTALLATION

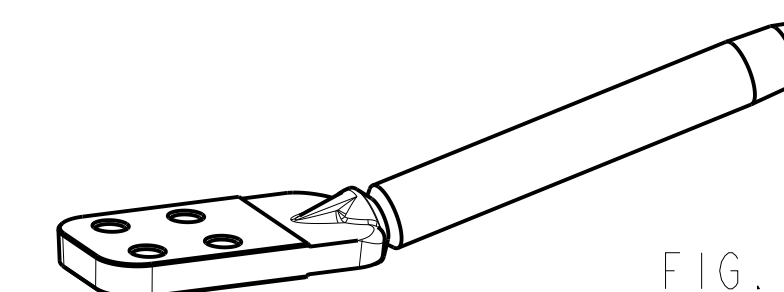
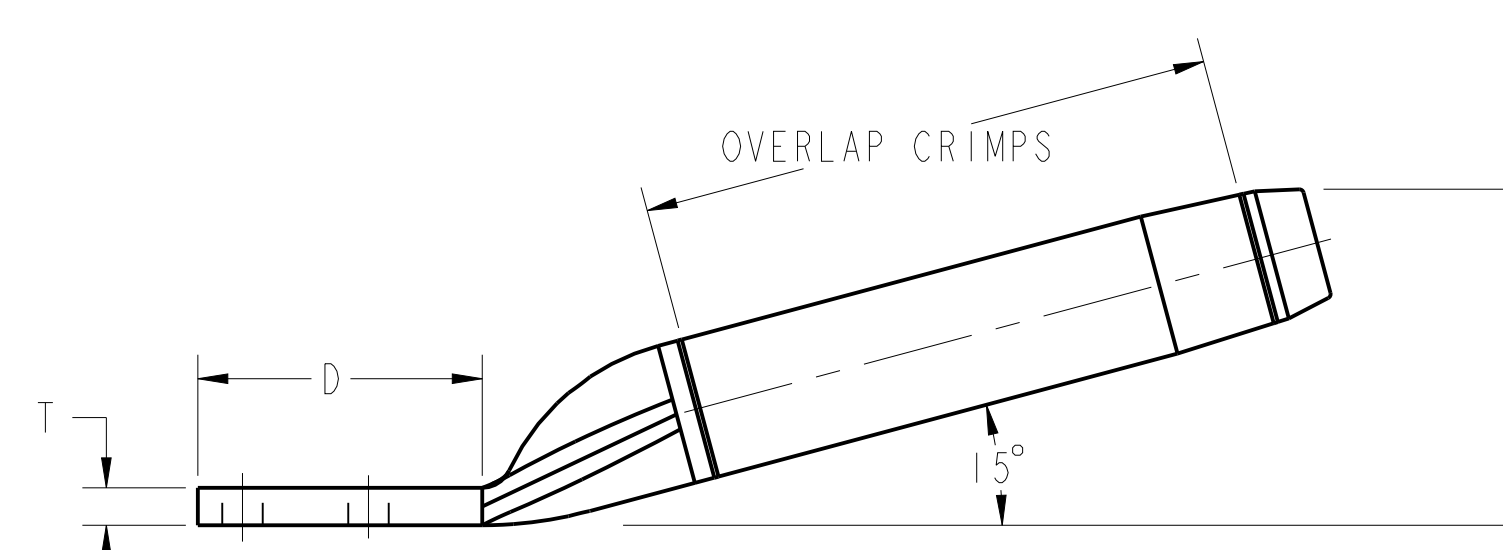

COMPRESSION TERMINAL CONNECTOR FOR
(ACCC® ALUMINUM CONDUCTOR COMPOSITE CORE)

TO ORDER BURNDY® PRODUCTS CALL		15 DEG HYLUG™ & HARDWARE (ACCC)	
UNITED STATES		ITEM NO: SEE TABLE	
1-800-346-4175 (LONDONDERRY, NH)		CAT. NO: SEE TABLE	
CANADA:		DRAWN BY: VIMAL C 02/23/16	
1-800-361-6975 (QUEBEC)		CHECKER: MANIKANDAN B 02/23/16	
1-800-387-6487 (ALL OTHER PROVINCES)		DSN APPVL: P CHAN 02/08/16	
FOR PRODUCT INFO: http://www.burndy.com		MFG APPVL:	
		QA APPVL: KOWALCZYK C 02/10/16	
		MKT APPVL: B CRUTCHER 02/09/16	
		PROD FAM: Transmissio/YNA	
		SCALE: 3:8	
		PROJECT #: --	
		SIZE	
		50068174	
		DOCUMENT TYPE: Sales	
		SHEET 1 OF 1	
		REL LEVEL: In Work	

