

DRAWING NO.
50068519

7

6

5

4

3

2

1

BURNDY® PRODUCTS - HYLUG™ & HARDWARE

REV	DATE	DESCRIPTION	ECO	BY	C'H'K.
A	02/22/2016 00:00:00 AM	NEW DRAWING CREATED	42929	ARJ	MB

ITEM NUMBER	6 CATALOG NUMBER	ACCOMMODATES ACCC® CONDUCTOR		5 CONTAINS HARDWARE KIT CAT. #	CTC NUMBER	DIMENSIONS								7 INSTALLATION TOOLING (NOT INCLUDED)			
		CODE WORD	SIZE			C	D	L	N	O.D.	I.D.	T	H	TOOLS, DIE SETS			
										DIE INDEX Y45 Y46 Y60							
10092613	BYNA451RT15HACCC	DUBLIN	540mm ²	TMH24	600-253-5	3.22 [82]	3.95 [100]	15.0 [381]	.63 [16]	1.80 [46]	1.18 [30]	.45 [11]	4.45 [113]	725	S725	P725	L725W
10092612	BYNA451RT15ACCC			--													

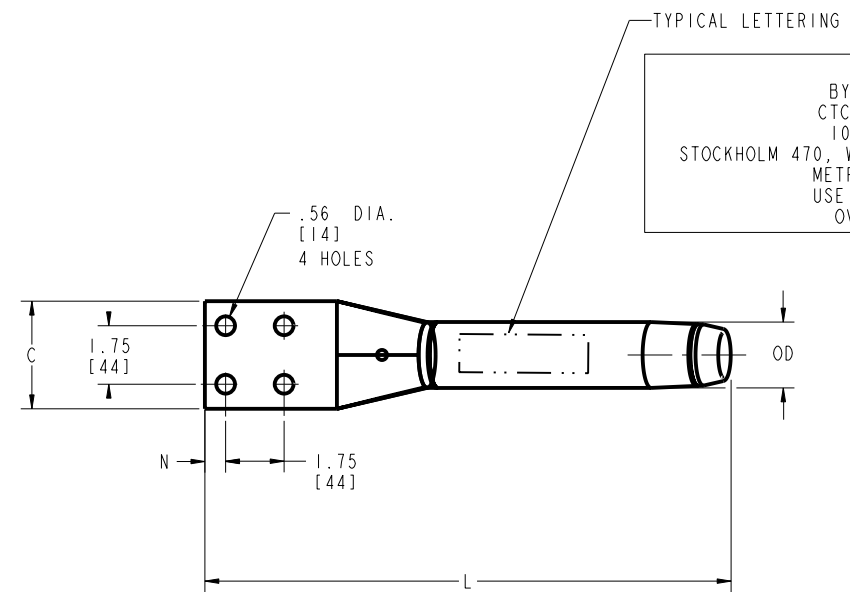

5 CATALOG NO. TMH24 HARDWARE KIT CONSIST OF	
QTY.	DESCRIPTION
4	BOLT, HEX. HEAD 1/2"-13 X 2" LONG
4	HEX. NUT, 1/2"-13
4	FLAT WASHER 1/2"
4	RESILIENT WASHER 1/2"

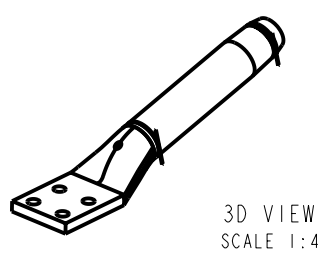
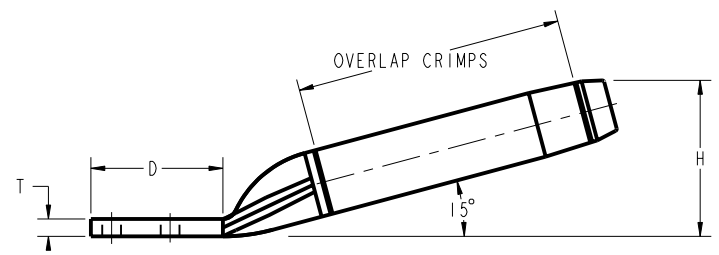

NOTES:

- MATERIAL:
 - CONNECTOR, ALUMINUM ALLOY, NO-OX-ID COATED
 - ALUMINUM FILLER PLUG
 - TMH24 HARDWARE
 - BOLTS (2024 T4), NUTS (6061 T6) AND FLAT WASHERS, ALUMINUM ALLOY
 - RESILIENT WASHERS, GALVANIZED STEEL
- DIMENSIONS IN BRACKETS [] DENOTE METRIC UNITS [SI UNITS] AND ARE ROUNDED TO THE NEAREST WHOLE NUMBER. UNLESS OTHERWISE SPECIFIED THESE UNITS SHALL BE USED FOR REFERENCE ONLY.
- DESIGNED FOR CORONA FREE OPERATION TO 230 KV NO ACCESSORIES REQUIRED.
- CONNECTOR SHALL BE SHIPPED UN-ASSEMBLED.

- RECOMMENDED TIGHTENING TORQUE: 1/2-13 ALUMINUM HARDWARE: 300 LBS-IN [34 NM]
- CATALOG NUMBER FOR HYLUG™ WITHOUT HARDWARE ARE CATALOG NUMBERS WITHOUT "H".
- REFERENCE: 10092621, CONNECTOR INSTALLATION.

COMPRESSION TERMINAL CONNECTOR FOR (ACCC®) ALUMINUM CONDUCTOR COMPOSITE CORE

TO ORDER BURNDY® PRODUCTS CALL		15 DEG HYLUG™ & HARDWARE (ACCC®)	
UNITED STATES 1-800-346-4175 (LONDONDERRY, NH)		ITEM NO: SEE TABLE CAT. NO: SEE TABLE	
CANADA: 1-800-361-6975 (QUEBEC) 1-800-387-6487 (ALL OTHER PROVINCES)		DRAWN BY: ARJUN 2/22/2016 CHECKER: MANIKANDAN 2/22/2016 DSN APPVL: P. CHAN 2/10/2016 MFG APPVL: -- -- QA APPVL: C. KOWALCZYK 2/10/2016 MKT APPVL: B. CRUTCHER 2/12/2016	
FOR PRODUCT INFO: http://www.burndy.com		SCALE: 3:8	
		PROJ. #: -- SIZE: D	
		DRAWING NO: 50068519	
		REV: A	
		SHEET 1 OF 1	

REV: PE0200

8

7

6

5

4

3

2

1