

CLAMP RUN	COPPER CONDUCTOR RANGE ACCOMMODATED		TORQUE LB IN [NM]
	MIN	MAX	
SMALL	6 SOL (.162)	4 STR (.232)	150 [17]
LARGE	1/0 SOL (.324)	4/0 STR (.528)	

REV	DATE	DESCRIPTION	ECO	BY	C'K.
B	04/06/2016	UPDATED AS PER MARKUP	43498	RW	MB

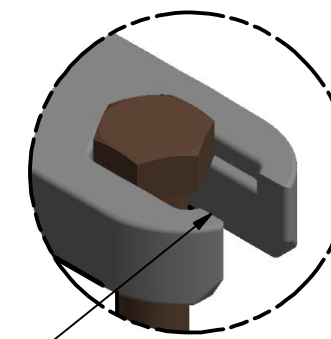

DETAIL A

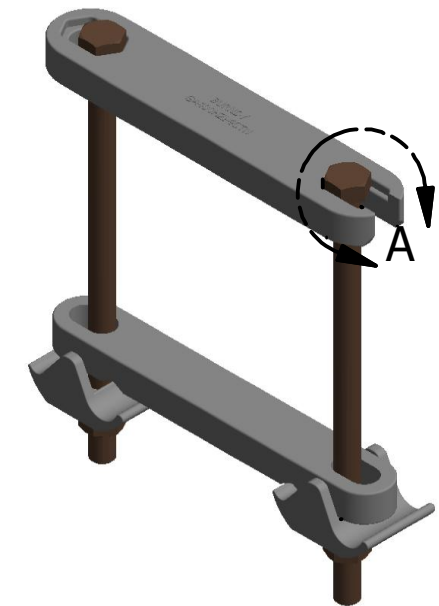
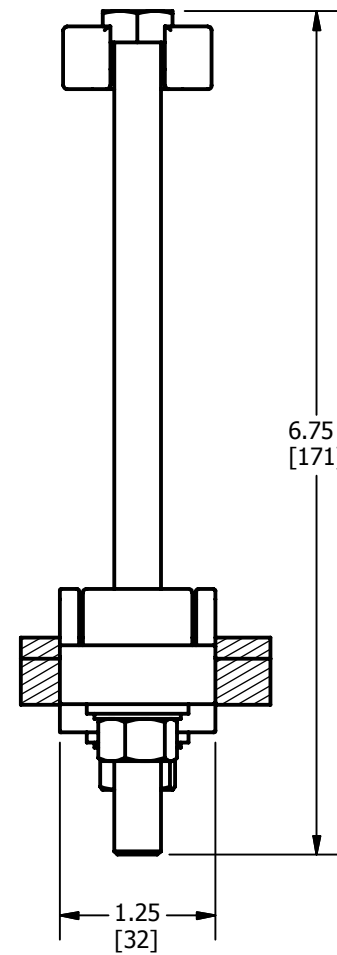
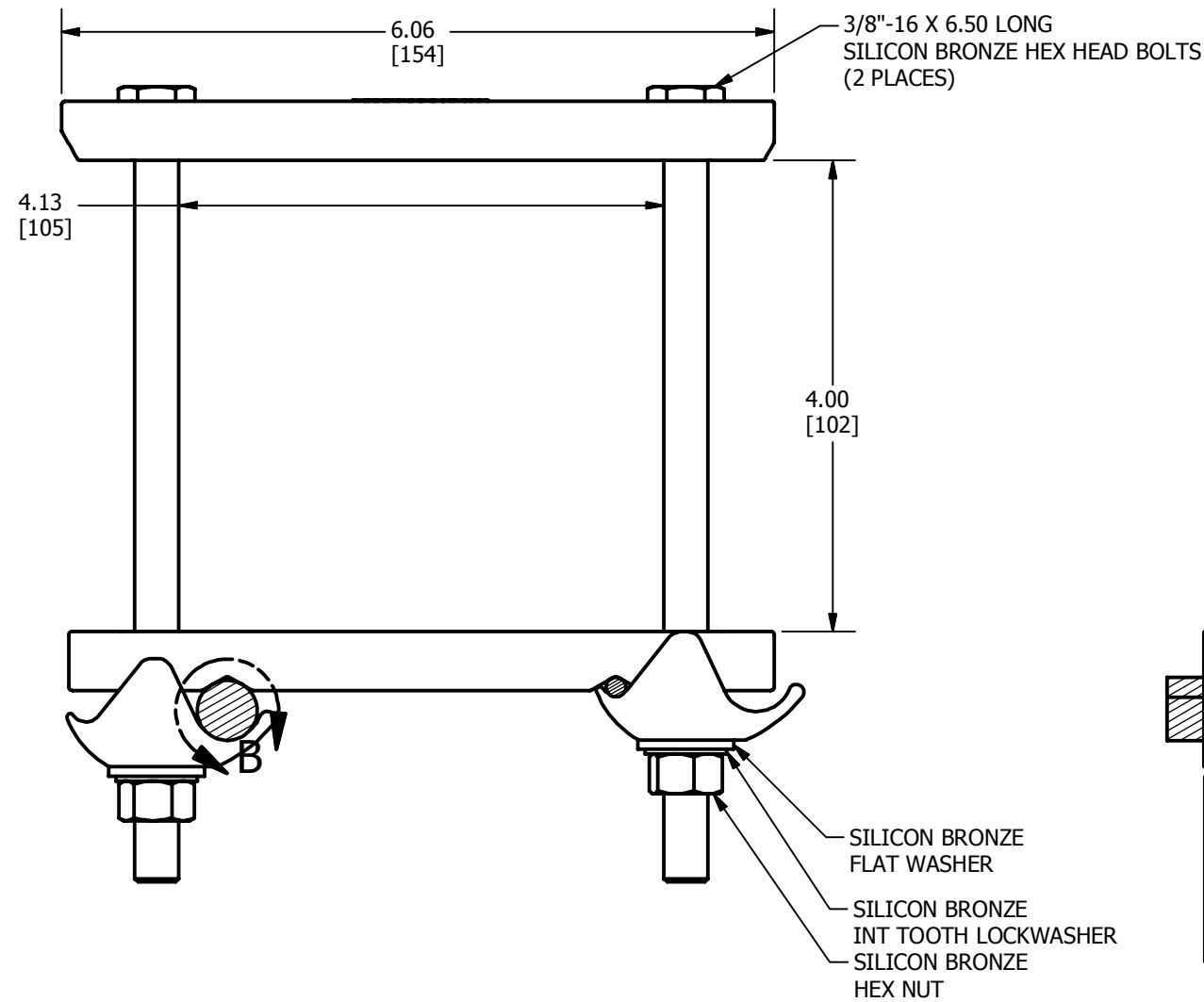
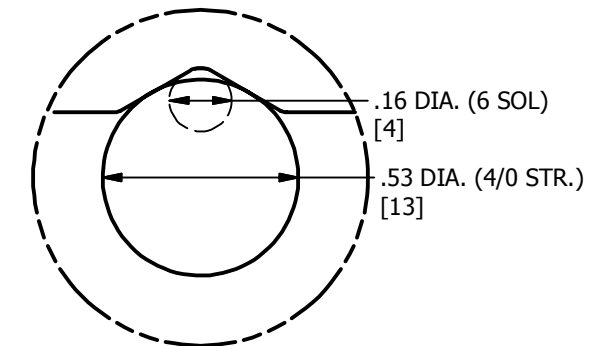

DETAIL B

BLOCKED TO PREVENT HEX HEAD FROM SLIDING OUT WHILE INSTALLED

**NOTES:**

- MATERIAL: CAST COPPER ALLOY  
FINISH: TIN PLATING  
HARDWARE: SILICON BRONZE
- DIMENSIONS IN BRACKETS [ ] ARE IN MILLIMETERS ROUNDED OFF TO THE NEAREST MILLIMETER, UNLESS OTHERWISE SPECIFIED AND ARE FOR REFERENCE ONLY.
- APPROXIMATE WEIGHT: 2.195 LBS

TO ORDER BURNDY PRODUCTS CALL		GROUND CLAMP FOR 'H' BEAM	
UNITED STATES		ITEM NO: 50068575	
1-800-346-4175 (LONDONDERRY, NH)		CAT. NO: GA400H294CTN	
CANADA:		DRAWN BY: B WHITE 02-08-2016	
1-800-361-6975 (QUEBEC)		CHECKER: G RUGGIERO 02-10-2016	
1-800-387-6487 (ALL OTHER PROVINCES)		DSN APRVL: -	
FOR PRODUCT INFO: <a href="http://www.burndy.com">http://www.burndy.com</a>		MFG APRVL: T.LOGAN 03-16-2016	
		QA APRVL: V.EDUARDO 03-28-2016	
		MKT APRVL: T.PETER 03-22-2016	
PROD FAM: GROUNDING	DRAWING NO	REV	
PROJECT #: FPN 1602005	SIZE	50068576	B
DOCUMENT TYPE: SALES	B	SHEET 1 OF 1	
REL LEVEL: Released			