

REV	DATE	DESCRIPTION	ECO	BY	C'H'K.
A	03/28/2016 00:00:00 AM	CREATE & CLEAN UP DOCUMENTATION FOR FD66C8 - 10022453	43355	BM	RL

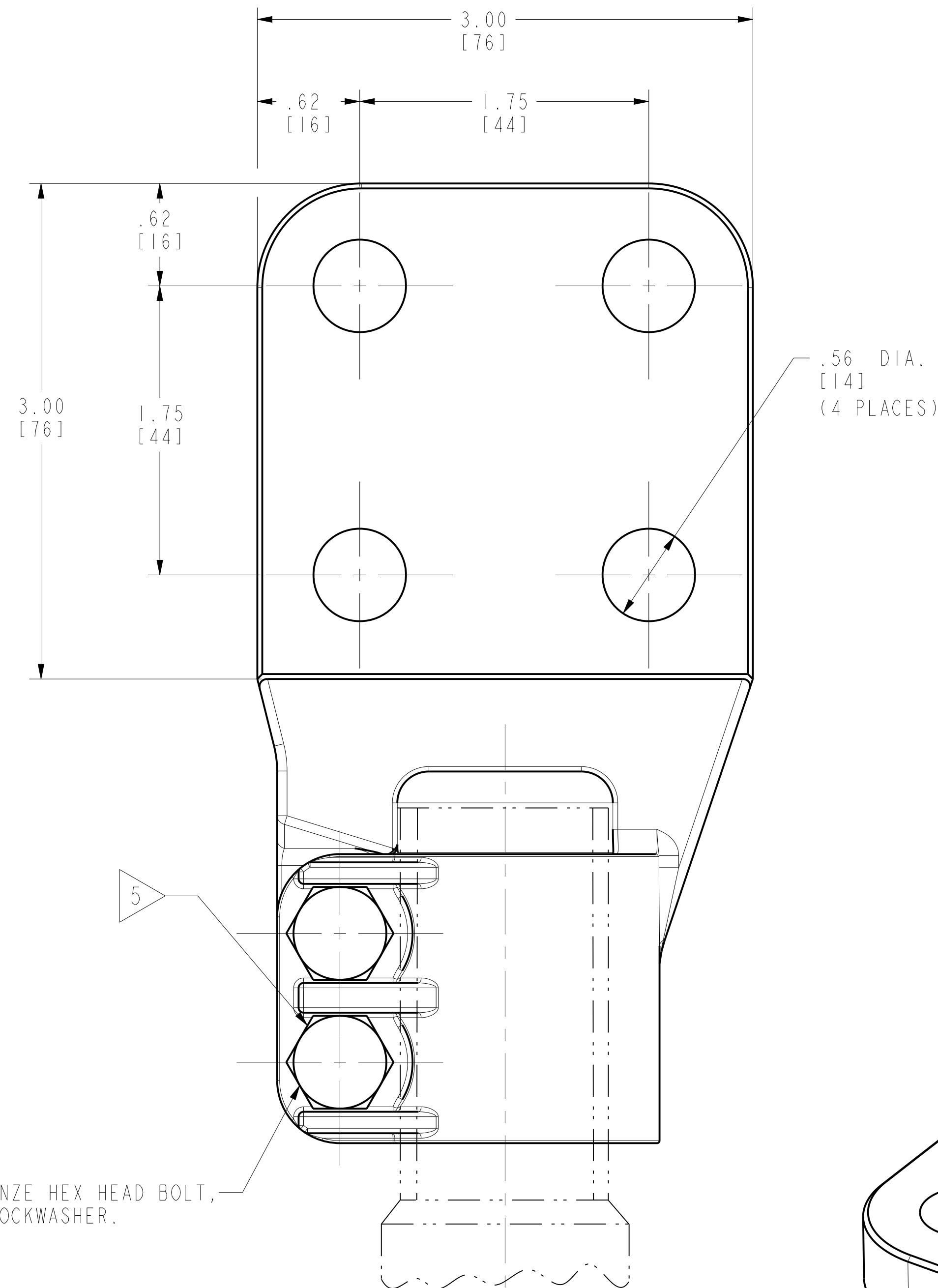

3/8"-16 SILICON BRONZE HEX HEAD BOLT,
HEX NUT AND SPLIT LOCKWASHER.
(2 PLACES)

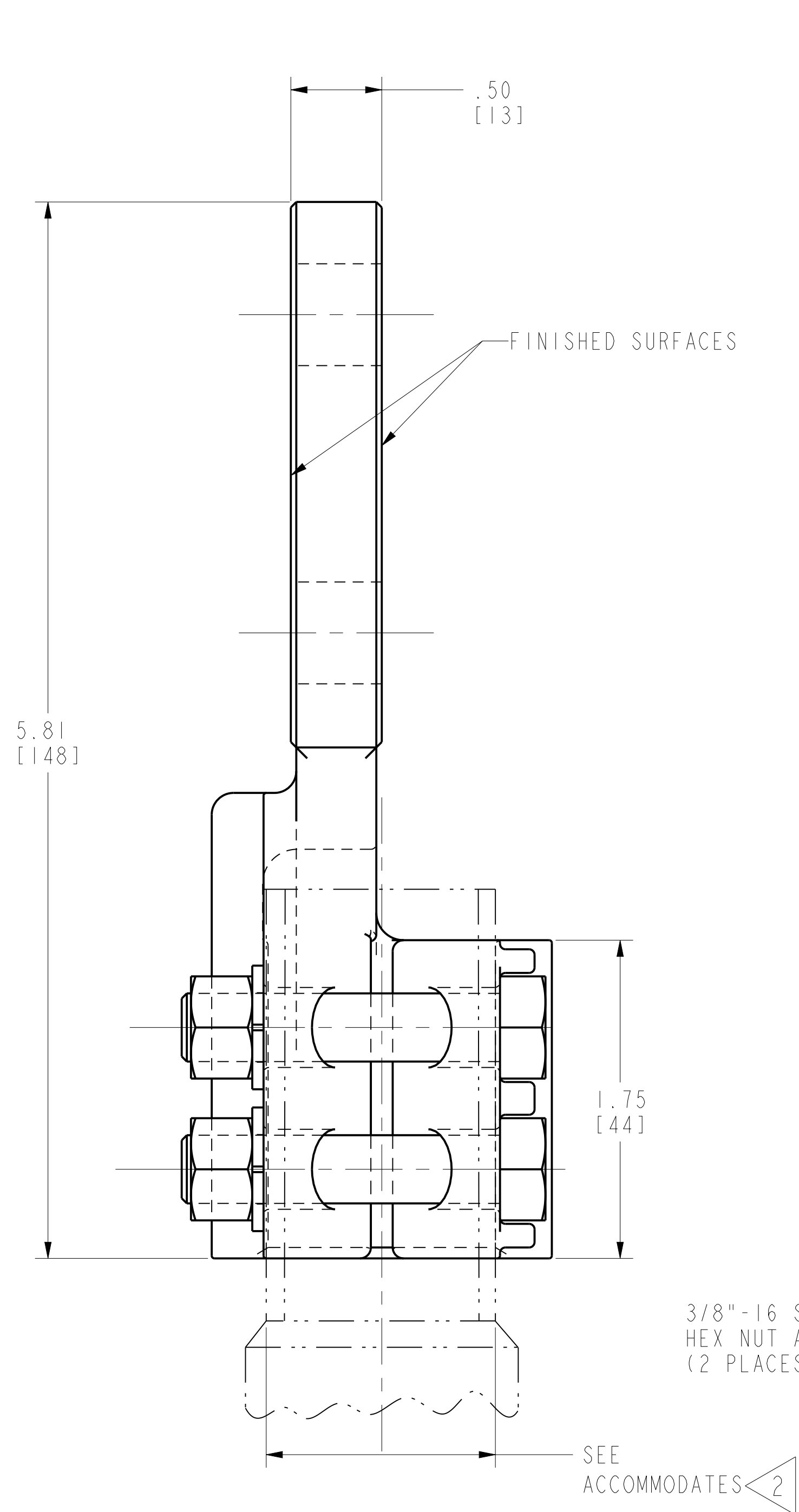
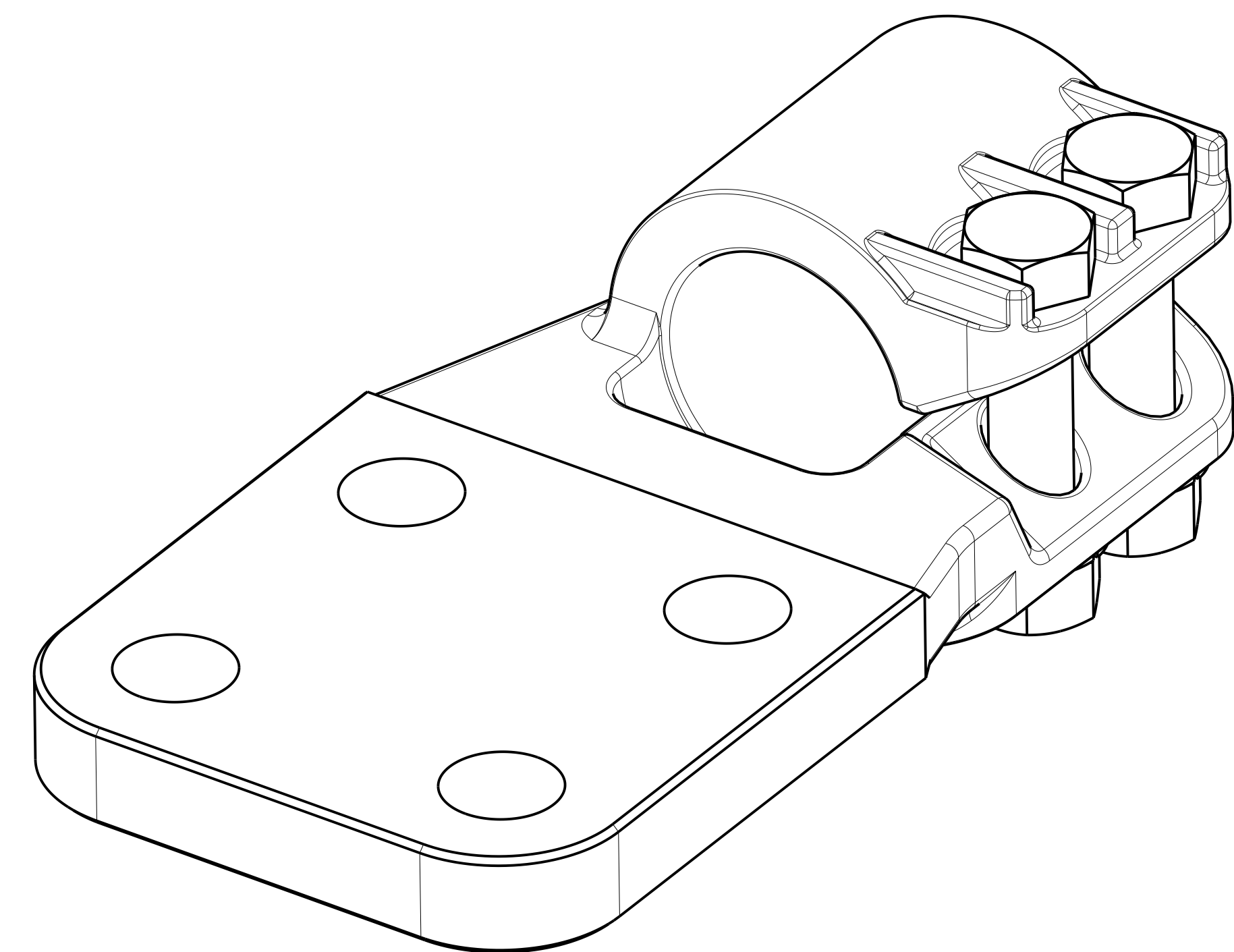

3D VIEW

NOTES:

- 1 MATERIAL:
CAST COPPER ALLOY.
- 2 ACCOMMODATES:
1 1/4"-12 UNF STUD
- 3 DIMENSIONS IN BRACKET [] DENOTES METRIC UNITS [SI UNITS]
AND ARE ROUNDED TO THE NEAREST WHOLE NUMBER UNLESS
OTHERWISE SPECIFIED THESE UNITS SHALL BE USED FOR
REFERENCE ONLY
- 4 NOMINAL BOLT INSTALLATION TORQUE:
3/8"-16 SILICON BRONZE HARDWARE 240 IN-LBS [30 Nm].
- 5 HEX BOLTS CAPTURED TO PREVENT TURNING DURING INSTALLATION.
- 6 MARKING
BURNDY
FD66C8
1 1/4"-12

TO ORDER BURNDY® PRODUCTS CALL UNITED STATES 1-800-346-4175 (LONDONDERRY, NH) CANADA: 1-800-361-6975 (QUEBEC) 1-800-387-6487 (ALL OTHER PROVINCES) FOR PRODUCT INFO: http://www.burndy.com		STUD CONNECTOR	
		ITEM NO: 10022453	CAT. NO: FD66C8
DRAWN BY: A. BALA 05/23/2012		CHECKER: NJ SUDHAKAR 05/23/12	
DSN APPVL: R. LAVOIE 03/30/16		MFG APPVL: T. WAWRZYNIAK 04/05/16	
QA APPVL: J. HILLMAN 03/31/16		MKT APPVL: B. MICHAUD 05/24/12	
PROD FAM: SUBSTATION	SIZE: D	DRAWING NO: 50070577	SCALE: 1:1
PROJECT #: --	DOCUMENT TYPE: Sales	SHEET 1 OF 1	REV: A
REL LEVEL: Released			



REV: PEC200