

REV	DATE	DESCRIPTION	ECO	BY	C'H'K.
A	11/09/2017	DWG RELEASED	47933	BK	MB

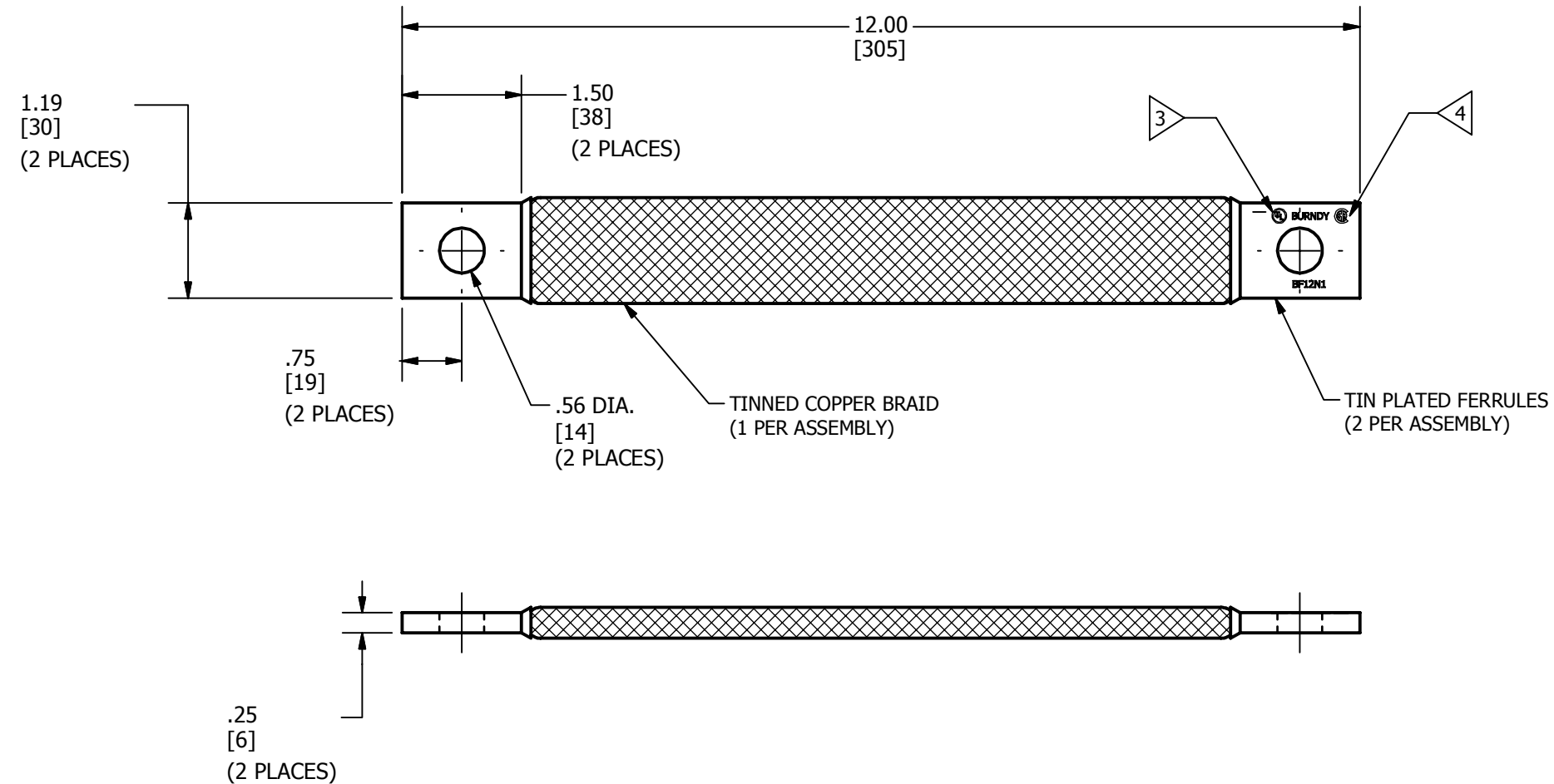

NOTES:

1. DIMENSIONS IN BRACKETS [] ARE IN MILLIMETERS IN ROUNDED OFF TO THE NEAREST MILLIMETER, UNLESS OTHERWISE SPECIFIED, AND ARE FOR REFERENCE ONLY.
2. APPROXIMATE AMP RATING: 360 INDOOR , 430 OUTDOOR THIS MAY VARY WITH AMBIENT CONDITIONS, ORIENTATION OF THE BRAID AND OTHER SERVICE CONDITIONS.
3. LISTED TO UL 467 BONDING & GROUNDING EQUIPMENT STANDARDS.
4. CERTIFIED TO CSA C22.2 NO. 41 BONDING & GROUNDING EQUIPMENT STANDARDS.
5. APPROXIMATE WEIGHT : 1.390 LBS

TO ORDER BURNDY® PRODUCTS CALL UNITED STATES 1-800-346-4175 (LONDONDERRY, NH) CANADA: 1-800-361-6975 (QUEBEC) 1-800-387-6487 (ALL OTHER PROVINCES) FOR PRODUCT INFO: http://www.burndy.com	BRAID		
	ITEM NO: 50067316		
	CAT. NO: BF12N1TN		
	DRAWN BY: SMOORTHY	4/27/2016	
	CHECKER: B.MANIKANDAN	4/27/2016	
	DSN APRVL: L.TROMBLEY	11/7/2017	
MFG APRVL: M.STEVENS	11/7/2017		
QA APRVL: C.LINDQUIST	11/7/2017		
MKT APRVL: K.ROBICHEAU	11/7/2017		
PROD FAM: MECHANICAL GROUNDING	DRAWING NO	REV	
PROJECT #:	SIZE	50071456	A
DOCUMENT TYPE: SALES	B		
REL LEVEL: Released		SHEET 1 OF 1	