

REV	DATE	DESCRIPTION	ECO	BY	C'HK.
A	08/16/2016	NEW SALES DRAWING CREATED	44693	ARJ	MB

WIRE RANGE (AWG / kcmil)	STUD SIZE	INSTALLATION TOOLING			WIRE STRIP LENGTH
		HYTOOL™	DIE INDEX	HYPRESS™ Y35, Y39, Y750 	
4/0 AIRCRAFT AN 4/0 FLEX	1/2	NON- RATCHET: MY28, MY29-11	46	UV28L NEST Y34PA INDENTOR (1) CRIMP	7/8"

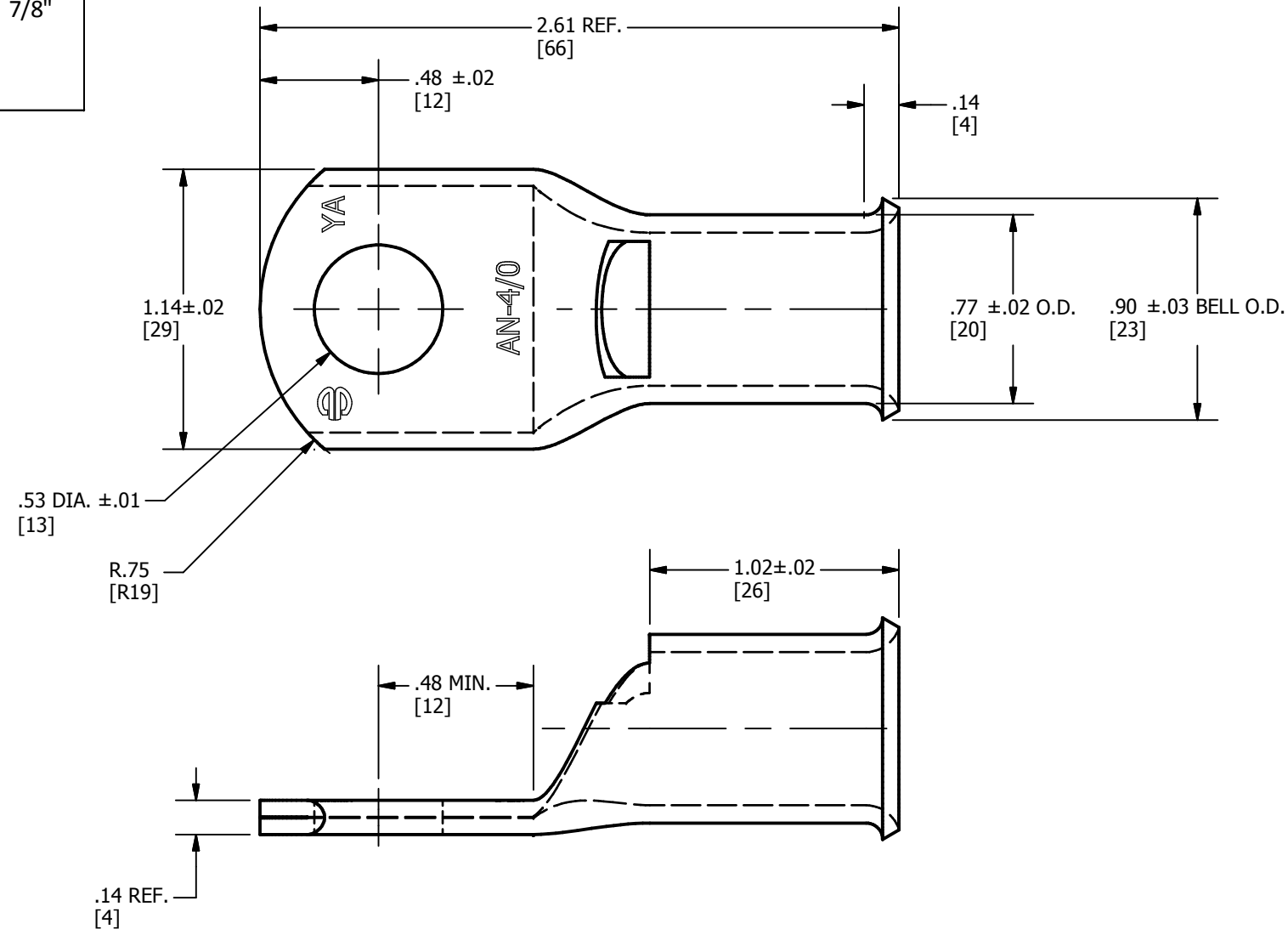

NOTES:

1. DIMENSIONS IN BRACKETS [] ARE IN MILLIMETERS ROUNDED OFF TO THE NEAREST MILLIMETER, UNLESS OTHERWISE SPECIFIED AND ARE FOR REFERENCE ONLY.

 USE Y35P3 INDENTOR ADAPTER WITH Y35 AND Y39 TOOL.

3. MATERIAL: COPPER TUBING.
FINISH: TIN PLATED.

TO ORDER BURNDY® PRODUCTS CALL		HYLUG™	
UNITED STATES 1-800-346-4175 (LONDONDERRY, NH)		ITEM NO: 27007604	
CANADA: 1-800-361-6975 (QUEBEC) 1-800-387-6487 (ALL OTHER PROVINCES)		CAT. NO: YAV28L12B	
FOR PRODUCT INFO: http://www.burndy.com		DRAWN BY: ARJUN 08/16/2016	
		CHECKER: MANIKANDAN B 08/16/2016	
		DSN APRVL: R ROMAN 08/22/2016	
		MFG APRVL: R ROMAN 08/22/2016	
		QA APRVL: T WATTS 08/19/2016	
		MKT APRVL: M BAILLY 08/24/2016	
PROJ #:	SIZE:	DRAWING NO:	REV:
PROJECT #:	B	50075492	A
DOCUMENT TYPE: SALES			
REL LEVEL: Released			